

RT SERIES

ROUGH TERRAINS SCISSOR LIFTS



Performance

Platform Height-Elevated	
3394RT	10.06 m
4394RT	13.11 m
530LRT	16.2 m
Platform Capacity	
3394RT	1,020 kg
4394RT	680 kg
530LRT	680 kg
Capacity on Platform Extension	
	227 kg
Capacity with Dual Extensions	
3394RT	907 kg
4394RT	567 kg
530LRT	680 kg
Lift/Lower Time	
3394RT	30/30 seconds
4394RT	40/43 seconds
530LRT	59/55 seconds
Maximum Drive Height	
3394RT	Full Height
4394RT	Full Height
530LRT	9.75 m
Weight with Dual Extensions	
3394RT	6,600 kg
4394RT	7,150 kg
530LRT	8,010 kg
Drive Speed - Lowered	
3394RT	6.4 km/h
4394RT	6.4 km/h
530LRT	5.6 km/h
Drive Speed - Raised	
3394RT	0.6 km/h
4394RT	0.6 km/h
530LRT	0.6 km/h
Gradeability	
3394RT	45%
4394RT	45%
530LRT	40%
Turning Radius (Inside)	
3394RT	2.71 m
4394RT	2.71 m
530LRT	2.72 m
Turning Radius (Outside)	
3394RT	5.93 m
4394RT	5.93 m
530LRT	5.92 m

* Certain options or country standards will increase weight.



Standard Specifications

Engine

Make and Model

Diesel	
3394RT	Deutz D2011L03 36.4 kW
4394RT	Deutz D2011L03 36.4 kW
530LRT	Kubota D1305 18.5 kW

Fuel Tank Capacity	
3394RT/4394RT	113.56 L
530LRT	83.3 L

Tyres

Standard Foam-Filled Non-Marking

Brakes

• 4 Wheel Spring Applied

Hydraulic Reservoir

• Capacity 121.42 L

Standard Features

- 4-Wheel Drive
- Automatic Transmission
- Three-Speed Drive Select
- Proportional Drive/Lift Up/Lift Down
- Oscillating Axle
- Adjustable, Removable Platform Control Station
- Fold-Down Handrails
- Horn
- Tilt Light and Alarm
- Leveling Jacks¹
- Dual Extension Deck³
- Self-Closing Entry Gates¹
- Flashing Amber Beacon
-

Accessories & Options

- Platform Worklights
- Pipe Rack Accessory
- AC Outlet to Platform incl ELCB
- Wheel Chocks
- Squawker / White Noise Motion Alarm
- 5.5kVA Generator – 530LRT only

RT SERIES

ROUGH TERRAINS SCISSOR LIFTS



Dimensions

All dimensions are approximate.

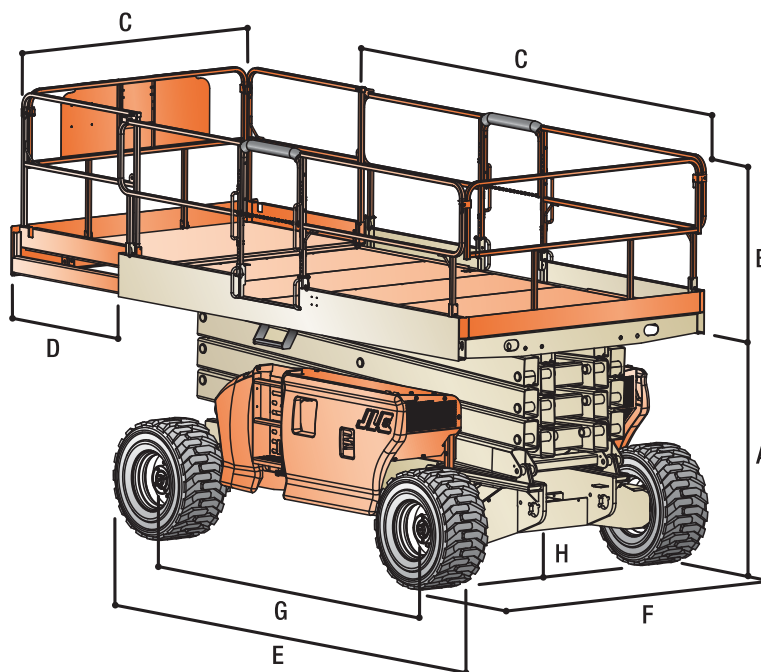

Platform Height — Elevated

3394RT	10.06 m
4394RT	13.11 m
530LRT	16.2 m

A. Platform Height - Lowered

3394RT	1.57 m
4394RT	1.79 m
530LRT	2.13 m

B. Platform Railing Height

3394RT	1.1 m
4394RT	1.1 m
530LRT	0.94 m

C. Platform Size

3394RT	2.18 x 3.81 m
4394RT	2.18 x 3.81 m
530LRT	1.87 x 3.96 m

D. Platform Extension

1.22 m

E. Overall Length

3394RT	3.86 m
4394RT	3.86 m
530LRT	5.18 m

F. Overall Width

3394RT	2.39 m
4394RT	2.39 m
530LRT	2.31 m

G. Wheelbase

3394RT	2.95 m
4394RT	2.95 m
530LRT	2.97 m

H. Ground Clearance

30 cm



The JLG "1 & 5" Warranty

JLG Industries, Inc. backs its products with its exclusive "1 & 5" Warranty. We provide coverage on all products for one (1) full year and cover all specified major structural components for five (5) years. Due to continuous product improvements, we reserve the right to make specification and/or equipment changes without prior notification. This machine meets or exceeds AS/NZS 1418.10 2011 as originally manufactured for intended applications.

JLG Industries (Australia)

358 Park Road
Regents Park, NSW 2143
Telephone 02 8718 6300
Fax 02 8718 6377
www.jlg.com.au

An Oshkosh Corporation Company