



MINI AUGER DRIVE

From Digga's Premium Drive Range comes the most compact mini drive for tough mini machines.

Features:

- Quality Digga New Generation Gearbox & Motor
- High quality bearings and components

Standard Model Features:

- Convertible axis for 2 way or 4 way swing options.
- Safety Stops preventing damage to hoses, cement mixa and machines
- New Cradle Design allowing for quick cement mixa addition

Ideal Use:

Fencing, tree planting, house foundations and more

Machine Suitability:

Mini Machines, Mini Excavators, Small Skid Steer Loaders

Specifications	Standard Model 2 Way (Single Swing)	Standard Model 4 Way (Dual Swing)
A Length (overall)	434mm	475mm
B Width (overall)	615mm	615mm
C Height (overall)	483mm	483mm
Motor	Eaton	Eaton
Rec Flow (LPM)	20-60	20-60
Max Flow (LPM)	Do not exceed 60lpm @ 160bar	
Max Pressure (BAR)	Do not exceed 205bar @ 40lpm	
Torque (Nm)	2900Nm @ 205bar	
Weight	62kgs	65kgs

Digga Have a Full Range of Premium Drives,
Supa Drives and Mega Drive also available

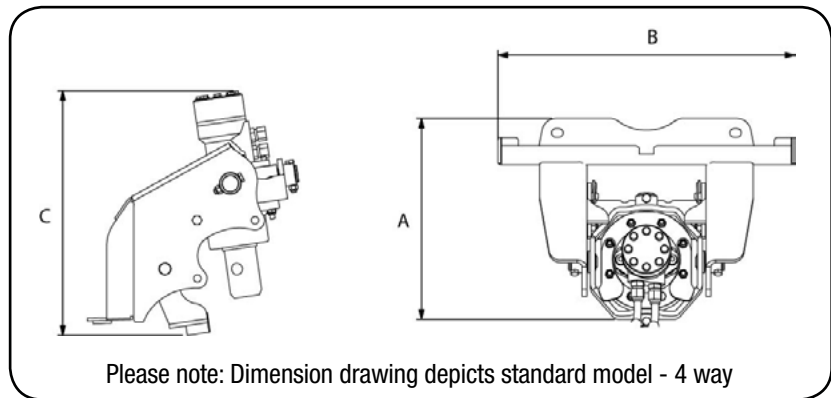

Please note: Dimension drawing depicts standard model - 4 way

Contact your local professional dealer or contact Digga direct

THE BEST DOWNUNDER

DIGGA

PHONE: 1300 2 DIGGA EMAIL: info@digga.com WEB: www.digga.com

QLD, NT
4 Octal Street
Yatala QLD 4207

NSW, ACT
20 Mckay Close
Wetherill Park NSW 2164

VIC, SA, TAS
27 Metcalf Street
Dandenong VIC 3175

WA
6/15 Yampi Way
Willetton WA 6155

