

Technical sheet :

1050 RT



Capacities		Metric
Max. capacity	Q	1361 kg
Operating Weight		2141 kg
Unladen weight		1928 kg
Operating Capacity at 35% Tipping Load		476 kg
Operating Capacity At 50% Tipping Load		680 kg
Tipping capacity		1361 kg
Weight and dimensions		
Overall Operating Height - Fully Raised	h27	3650 mm
Height to Hinge Pin - Fully Raised	h28	2769 mm
Reach - Fully Raised	dp1	673.1 mm
Dump angle at full height	a5	38 °
Dump Height - Fully Raised	h29	2134 mm
Maximum Rollback Angle - Fully Raised	a4	102 °
Overall Height to Top of ROPS	h17	1816 mm
Overall length with bucket	l16	2985 mm
Overall Length without Bucket	l1	2258 mm
Specified Height	h31	1466 mm
Reach at Specified Height	r4	991 mm
Dump angle at specified height	a17	72 °
Maximum Rollback Angle at Ground	a13	32 °
Carry Position	d5	127 mm
Maximum Rollback Angle at Carry Position	a14	32 °
Digging Position	h32	0 mm
Angle of Departure with STD Counterweight		35 °
Ground clearance	m4	191 mm
Track gauge	b10	1039 mm
Track Shoe Width	b20	250 mm
Crawler base	y2	1283 mm
Overall width less bucket	b1	1290 mm
Bucket Width	e1	1372 mm
Clearance Radius - Front with Bucket		1854 mm
Clearance Circle - Rear	wa1	1290 mm
Maximum rollback at specified height		72 °
Angle of Approach		90 °
Grouser Height		25 mm
Track Type / Track Rollers / Roller Type		Rubber / 4 / Steel
Performances		
Ground Speed - Single Speed		10.1 km/h
Drawbar Pull/Tractive Effort		1996 kg
Bucket Breakout - Tilt Cylinder		1346 kg
Bucket Breakout - Lift Cylinder		1376 kg
Engine		
Engine brand		Yanmar
Engine model		3TNV88C-KMS
Motor Type		Radial Piston
Gross Power (kW) / Gross Power		25.5 kW / 2800 rpm
Net Power (kW) / Net Power		23.7 kW / 2800 rpm
Max. torque		109.4 Nm
Battery		12 V
Cold Cranking Amps at Temperature (CCA)		800 A
Alternator - Voltage / Ampere		12 V / 55 A
Hydraulics		
Auxiliary hydraulics		55 l/min
Tank capacities		
Oil Pan Capacity		5.87 l
Hydraulic tank capacity		30 l
Fuel tank		36 l
Coolant Capacity		6.62 l
Displacement / Number of cylinders		1.64 l / 3
Noise and vibration		
Environmental noise (LwA)		101 dB(A)
Noise at driving position (LpA)		85.8 dB(A)
Miscellaneous		

Miscellaneous

Ground Pressure

0 Bar

Dimensional drawing

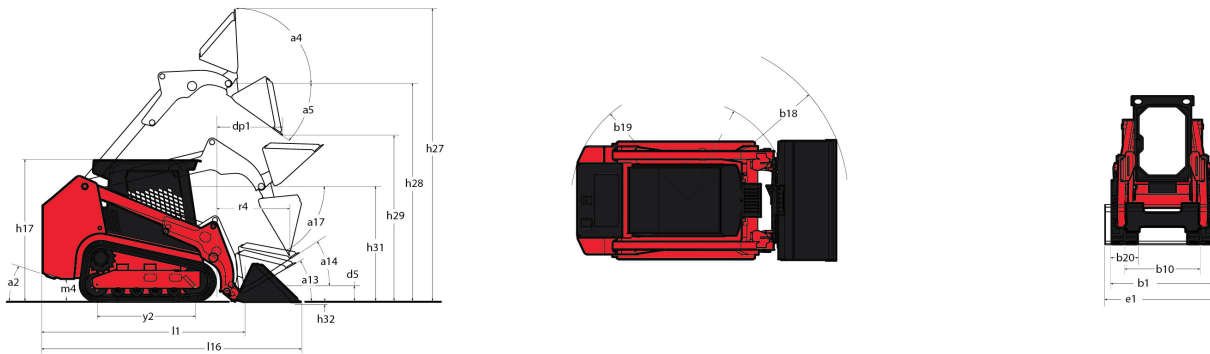

Equipment

Selectable Self-Leveling Hydraulic Lift Action 4	Optional
Lifting function	
All-Tach® Attachment Mounting System	Standard
Auxiliary Hydraulics	Standard
IdealTrax™ Automatic Track Tensioning System	Standard
Motorization/Power	
Combination Radiator & Hydraulic Oil Cooler	Standard
Dual-Element Air Cleaner with Indicator	Standard
Engine Auto-Shutdown System	Optional
Glowplugs Starts Assist	Standard
Operator station	
Foot Throttle	Standard
Full-Suspension Seat	Optional
Multi-Function Function Display Screen	Standard
ROPS/FOPS Level II Overhead Guard	Standard
Sliding Side Windows	Standard
Swing-out Cab Door	Standard
Pneumatics	
Rubber Track Undercarriage System	Standard
Safety	
Anti-Vandalism Protection	Standard
Back-Up Alarm	Standard
Easy Manager	Standard
Engine Alert System with Error Display	Standard
Mechanical Lift Cylinder Lock	Standard
Secondary functions	
Counterweight	Standard
Dedicated Undercarriage	Standard



Siège Social
430 rue de l'Aubinière - 44150 Ancenis Cedex - France
Tel: +33(0)2 40 09 10 11 - Fax: +33 (0)2 40 09 10 97
www.manitou.com



This brochure describes versions and configuration options for Manitou products which may be fitted with different equipment. The equipment described in this brochure may be standard, optional or not available depending on version. Manitou reserves the right to change the specifications shown and described at any time and without prior warning. The manufacturer is not liable for the specifications given. For more information, contact your Manitou dealer. Non-contractual document. Product descriptions may differ from actual products. List of specifications is not comprehensive. The logos and visual identity of the company are the property of Manitou and may not be used without authorisation. All rights reserved. The photos and diagrams contained in this brochure are provided for information only.

MANITOU BF SA - Limited company with board of directors - Share capital: 39,668,399 euros - 857 802 508
RCS Nantes