

# WL20e

## WL20e



**WACKER  
NEUSON**  
*all it takes!*



### **Innovative, electric, emission-free - the wheel loader with electric drive**

The WL20e wheel loader model is the first purely electrically operated wheel loader from Wacker Neuson. As with all of our wheel loaders, it convinces through first-class performance. Two electric engines, one for the drive system and one for the work hydraulics, ensure that the performance features of the WL20e correspond to those of the conventional machine. At the same time, the wheel loader works completely exhaust free and with significantly lower noise emissions. For the end user, this means greater flexibility in application, environmental protection and significant savings with operating costs.

- 100% emission-free thanks to wireless battery drive system
- Up to five hours of running time
- Comparable performance as with conventional wheel loaders
- Up to 41% savings in operating costs as well as cost advantages in maintenance and in the service intervals
- Significantly lower noise pollution

## WL20e Technical specifications

WL20e

### Engine / Motor

Travel drive motor - capacity S2 (60 min.)	6.5 kW
Lifting motor - capacity S3 (15%)	9 kW

### Battery Standard

Battery	48 V
Rated capacity K5	230 Ah
Battery weight ( $\pm 5\%$ )	450 kg
Charging time	8 h
Running time under long-time application with heavy materials handling, uninterrupted operation	1.5* h
Running time under normal activities, uninterrupted operation	2-3.5* h
Running time under normal activities with interruptions (30 min. driving time, 30 min. standstill)	up to 4* h

### Battery Optional

Battery	48 V
Rated capacity K5	310 Ah
Battery weight ( $\pm 5\%$ )	579 kg
Charging time	6 h
Running time under long-time application with heavy materials handling, uninterrupted operation	2.1* h
Running time under normal activities, uninterrupted operation	2.8-4.5* h
Running time under normal activities with interruptions (30 min. driving time, 30 min. standstill)	up to 5* h

### Electrical system

Operating voltage	12 V
-------------------	------

### Weights

Operating weight	2,350 kg
Tipping load with bucket - machine straight	1,509 kg
Tipping load with bucket - machine at angle	1,251 kg
Tipping load with pallet fork - machine straight	1,112 kg
Tipping load with pallet fork - machine at angle	916 kg

### Vehicle data

Bucket capacity Standard bucket	0.2 m <sup>3</sup>
Traction drive	electrically via universal joint shaft
Axles	T80
Drivers cab (optional)	FSD (EPS, EPS Plus)
Speed	0 - 15 km/h
Speed Level	1
Standard tires	27 x 10.50-15 EM ET-5

### Hydraulic system

Operating hydraulics - operating pressure	225 bar
---	---------

Operating hydraulics - discharge capacity	32 l/min
---	----------

**Filling capacities**

Hydraulic oil tank	18.5 l
--------------------	--------

Hydraulic system	37 l
------------------	------

Standard bucket = digging bucket, 1,500 mm width

FSD = operator's canopy

EPS = Easy Protection System (fold-down operator's canopy)

EPS Plus = Easy Protection System Plus (hydraulically lowerable operator's canopy)

Tipping load calculation according to ISO 14397-EN474-3

\*The running times of the battery are strongly dependent on the respective application conditions, the task and the driving style. This may also mean that a longer running time can be achieved. The specified running times may also be fallen short of in extreme cases. An interrupted operation (e.g. 30 min. driving, 30 min. standstill) prolongs the running time of the battery.

## WL20e Dimensions

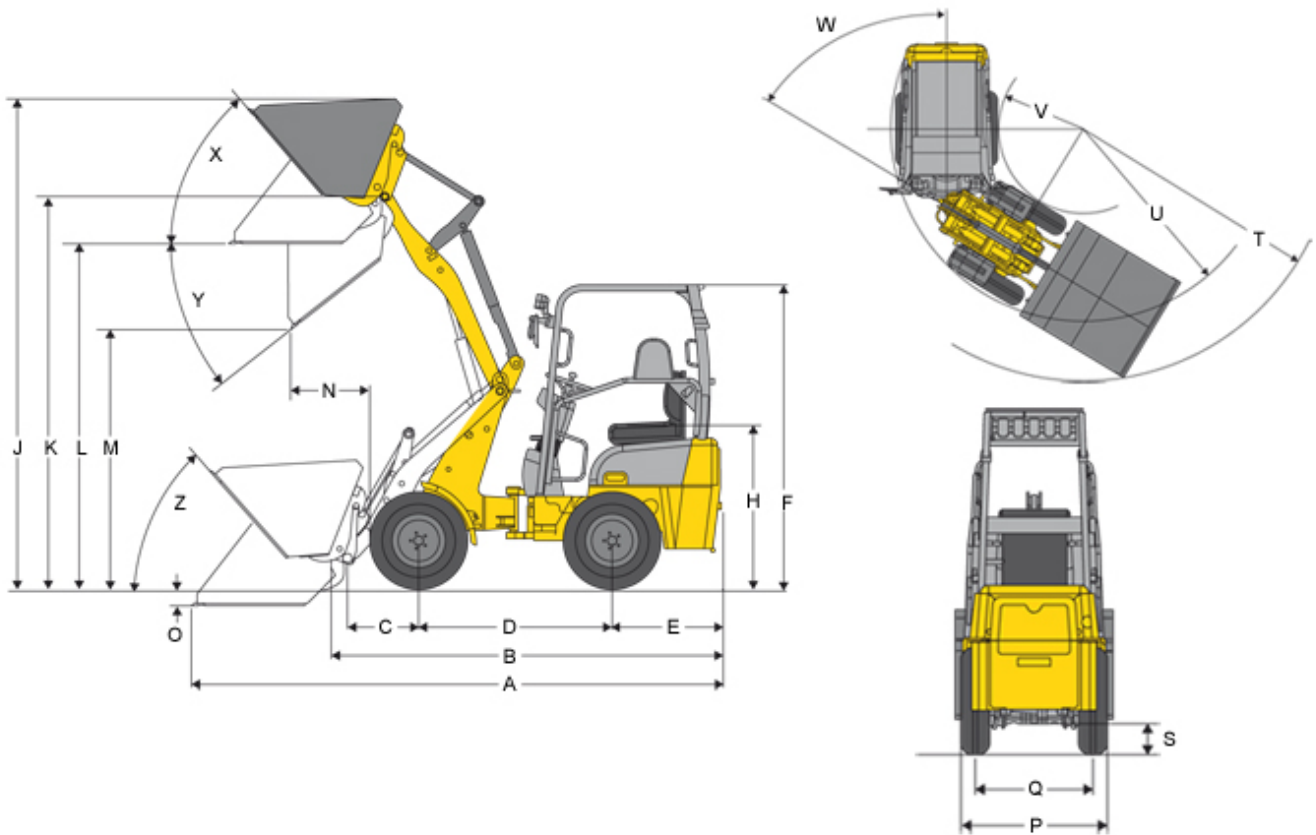

	Standard tires	27 x 10.5-15 EM ET-5
A	Overall length	3,721 mm
B	Overall length without bucket	3,063 mm
C	Bucket pivot point to axle center	508 mm
D	Wheelbase	1,468 mm
E	Rear overhang	975 mm
F	Height With operator's canopy	2,209 mm
F	Height With fold-down operator's canopy (EPS)	2,351 mm
F	Height With fold-down operator's canopy (EPS), folded-down	1,928 mm
F	Height With lowerable operator's canopy (EPS Plus)	2,255 mm
F	Height With lowerable operator's canopy (EPS Plus), lowered	1,961 mm
H	Seat height	1,245 mm
J	Total operating height	3,294 mm
K	Stroke height max. - bucket pivot point	2,713 mm
L	Overhead loading height	2,444 mm
M	Dump height max.	2,031 mm
N	Range with M	330 mm
O	Scraping depth	74 mm
P	Overall width	1,076 mm
Q	Track width	810 mm

S	Ground clearance	207 mm
T	Radius maximum	2,681 mm
U	Radius at outer edge max.	2,356 mm
V	Inside turning radius	1,219 mm
W	Articulation angle	45 °
X	Bucket rollback at max. stroke height	50 °
Y	Dump angle Maximum	38 °
Z	Bucket rollback at ground level	48 °

All values with standard bucket: Digging bucket 1,150 mm, 0.2 m<sup>3</sup> and standard tires: 27 x 10.5-15 EM ET-5

Please note: that product availability can vary from country to country. It is possible that information / products may not be available in your country. More detailed information on engine power can be found in the operator's manual; the stated power may vary due to specific operating conditions. Subject to alterations and errors excepted. Applicable also to illustrations.

Copyright © 2020 Wacker Neuson SE.