

Atlas Copco

Instruction Manual



Instruction Manual
for Portable Compressors
English

XAHS 146 Dd S3A APP - XAHS 300 DD6 T3 APP
XATS 156 Dd S3A APP - XATS 350 DD6 T3 APP
XA(S) 186 Dd S3A APP - XA(S) 375 DD6 T3 APP
XAVS 166 Dd S3A APP - XAVS 340 DD6 T3 APP
XAHS 186 Dd S3A APP - XAHS 375 DD6 T3 APP

Engine
Deutz
TCD

XATS 156 Dd S2A APP - XATS 350 DD6 T2 APP
XA(S) 186 Dd S2A APP - XA(S) 375 DD6 T2 APP

Engine Deutz
BF4M

Atlas Copco

**Instruction Manual
for Portable Compressors**

XAHS 146 Dd

XATS 156 Dd

XA(S) 186 Dd

XAVS 166 Dd

XAHS 186 Dd

Printed matter N°
2954 2230 05

09/2010

The Atlas Copco logo consists of the brand name "Atlas Copco" in a stylized, italicized serif font. It is positioned between two thick, solid black horizontal bars.

ATLAS COPCO - PORTABLE AIR DIVISION
www.atlascopco.com

Warranty and Liability Limitation

Use only authorized parts.

Any damage or malfunction caused by the use of unauthorized parts is not covered by Warranty or Product Liability.

The manufacturer does not accept any liability for any damage arising for modifications, additions or conversions made without the manufacturer's approval in writing.

While every effort has been made to ensure that the information in this manual is correct, Atlas Copco does not assume responsibility for possible errors.

Copyright 2010, Atlas Copco Airpower n.v., Antwerp, Belgium.

Any unauthorized use or copying of the contents or any part thereof is prohibited.

This applies in particular to trademarks, model denominations, part numbers and drawings.

Preface

Please read the following instructions carefully before starting to use your machine. Follow the instructions in this booklet and we guarantee you years of troublefree operation.

Always keep the manual available near the machine.

In all correspondence always mention the compressor type and serial number, shown on the data plate.

The company reserves the right to make changes without prior notice.

Table of contents

1	Safety precautions for portable compressors 7	
1.1	Introduction	7
1.2	General safety precautions	8
1.3	Safety during transport and installation	9
1.4	Safety during use and operation	9
1.5	Safety during maintenance and repair	11
1.6	Tool applications safety	12
1.7	Specific safety precautions	13
2	Leading particulars	14
2.1	Description of safety pictograms used in this manual 14	
2.2	General description	14
3	Main Parts	16
3.1	Compressor regulating system	20
3.1.1	Overview (Load condition)	20
3.1.2	Air flow	21
3.1.3	Oil system	21
3.1.4	Continuous regulating system	22
3.2	Electrical system	24
3.2.1	Dip switches for XAHS 146 Dd, XATS 156 Dd and XA(S) 186 Dd 25	
3.2.2	Dip switches for XAVS 166 Dd and XAHS 186 Dd 25	
3.3	Markings and information labels	26
4	Operating instructions	27
4.1	Parking, towing and lifting instructions	27
4.1.1	Parking instructions	27
4.1.2	Towing instructions	28
4.1.3	Height adjustment	29
4.1.4	Instructions ball coupling (option)	30
4.1.5	Lifting instructions	30
4.2	Starting/Stopping	31
4.2.1	Before starting	31
4.2.2	Control panel	31
4.2.3	During operation	32
5	Maintenance	33
5.1	Use of service paks	33
5.2	Preventive maintenance schedule for the compressor 33	
5.3	Fuel	36
5.4	Lubrication oils	36
5.5	Oil level check	38
5.5.1	Check engine oil level	38
5.5.2	Check compressor oil level	38
5.6	Oil and oil filter change	39
5.6.1	Engine oil and oil filter change	39
5.6.2	Compressor oil and oil filter change	39
5.7	Coolant specifications	40
5.7.1	PARCOOL EG	40
5.7.2	Handling PARCOOL EG	41
5.8	Coolant check	41
5.9	Topping up/replacing coolant	41
5.9.1	Topping up without draining from the cooling system 42	
5.9.2	Topping up after limited quantity draining from the cooling system 43	
5.9.3	Replacing the coolant	44
5.10	Cleaning coolers	44

CALIFORNIA

Proposition 65 Warning

Diesel engine exhaust and some of its constituents are known to the State of California to cause cancer, birth defects, and other reproductive harm.

5.11	Battery care.....	44	6.9.2	Lubrication.....	56
5.11.1	Electrolyte.....	45	7	Problem solving	58
5.11.2	Activating a dry-charged battery.....	45	8	Available options	61
5.11.3	Recharging a battery.....	45	9	Technical specifications	62
5.11.4	Battery maintenance.....	45	9.1	Torque values.....	62
5.12	Storage.....	45	9.1.1	For general applications.....	62
5.13	Service paks.....	45	9.1.2	For important assemblies.....	62
5.14	Service kits.....	45	9.2	Settings of shutdown switches and safety valves	63
5.15	Compressor element overhaul.....	45	9.3	Compressor/Engine/Generator specifications.	64
5.16	Liability.....	45	9.3.1	Reference conditions.....	64
6	Adjustments and servicing procedures ..	46	9.3.2	Limitations.....	65
6.1	Adjustment of the continuous regulating system	46	9.3.3	Performance data.....	66
6.2	Air filter engine/compressor.....	48	9.3.4	Design data.....	69
6.2.1	Cleaning the dust trap.....	48	10	Data plate	71
6.2.2	Recommendations.....	48	11	Disposal	72
6.2.3	Replacing the air filter element.....	48	11.1	General.....	72
6.3	Air receiver.....	48	11.2	Disposal of materials.....	72
6.4	Safety valve.....	48	12	Maintenance Log	73
6.5	Fuel system.....	49			
6.6	Brake (= option) adjustment.....	49			
6.7	Brake shoe adjustment.....	49			
6.7.1	Test procedure of brake cable adjustment...	50			
6.7.2	Brake cable adjustment.....	51			
6.8	Wheels.....	52			
6.8.1	Wheel check.....	52			
6.8.2	Lubrication.....	52			
6.8.3	Wheel bolts check.....	53			
6.8.4	Wheel bearing adjustment.....	54			
6.9	Towbar and overrun brake.....	55			
6.9.1	Towbar and overrun brake check.....	55			

Safety precautions for portable compressors



To be read attentively and acted accordingly before towing, lifting, operating, performing maintenance or repairing the compressor.

INTRODUCTION

The policy of Atlas Copco is to provide the users of their equipment with safe, reliable and efficient products. Factors taken into account are among others:

- the intended and predictable future use of the products, and the environments in which they are expected to operate,
- applicable rules, codes and regulations,
- the expected useful product life, assuming proper service and maintenance,
- providing the manual with up-to-date information.

Before handling any product, take time to read the relevant instruction manual. Besides giving detailed operating instructions, it also gives specific information about safety, preventive maintenance, etc.

Keep the manual always at the unit location, easy accessible to the operating personnel.

See also the safety precautions of the engine and possible other equipment, which are separately sent along or are mentioned on the equipment or parts of the unit.

These safety precautions are general and some statements will therefore not always apply to a particular unit.

Only people that have the right skills should be allowed to operate, adjust, perform maintenance or repair on Atlas Copco equipment.

It is the responsibility of management to appoint operators with the appropriate training and skill for each category of job.

Skill level 1: Operator

An operator is trained in all aspects of operating the unit with the push-buttons, and is trained to know the safety aspects.

Skill level 2: Mechanical technician

A mechanical technician is trained to operate the unit the same as the operator. In addition, the mechanical technician is also trained to perform maintenance and repair, as described in the instruction manual, and is allowed to change settings of the control and safety system. A mechanical technician does not work on live electrical components.

Skill level 3: Electrical technician

An electrical technician is trained and has the same qualifications as both the operator and the mechanical technician. In addition, the electrical technician may carry out electrical repairs within the various enclosures of the unit. This includes work on live electrical components.

Skill level 4: Specialist from the manufacturer

This is a skilled specialist sent by the manufacturer or its agent to perform complex repairs or modifications to the equipment.

In general it is recommended that not more than two people operate the unit, more operators could lead to unsafe operating conditions.

Take necessary steps to keep unauthorized persons away from the unit and eliminate all possible sources of danger at the unit.

When handling, operating, overhauling and/or performing maintenance or repair on Atlas Copco equipment, the mechanics are expected to use safe engineering practices and to observe all relevant local safety requirements and ordinances. The following list is a reminder of special safety directives and precautions mainly applicable to Atlas Copco equipment.

These safety precautions apply to machinery processing or consuming air. Processing of any other gas requires additional safety precautions typical to the application and are not included herein.

Neglecting the safety precautions may endanger people as well as environment and machinery:

- endanger people due to electrical, mechanical or chemical influences,
- endanger the environment due to leakage of oil, solvents or other substances,
- endanger the machinery due to function failures.

All responsibility for any damage or injury resulting from neglecting these precautions or by non-observance of ordinary caution and due care required in handling, operating, maintenance or repair, also if not expressly mentioned in this instruction manual, is disclaimed by Atlas Copco.

The manufacturer does not accept any liability for any damage arising from the use of non-original parts and for modifications, additions or conversions made without the manufacturer's approval in writing.

If any statement in this manual does not comply with local legislation, the stricter of the two shall be applied.

Statements in these safety precautions should not be interpreted as suggestions, recommendations or inducements that it should be used in violation of any applicable laws or regulations.

GENERAL SAFETY PRECAUTIONS

- 1 The owner is responsible for maintaining the unit in a safe operating condition. Unit parts and accessories must be replaced if missing or unsuitable for safe operation.
- 2 The supervisor, or the responsible person, shall at all times make sure that all instructions regarding machinery and equipment operation and maintenance are strictly followed and that the machines with all accessories and safety devices, as well as the consuming devices, are in good repair, free of abnormal wear or abuse, and are not tampered with.
- 3 Whenever there is an indication or any suspicion that an internal part of a machine is overheated, the machine shall be stopped but no inspection covers shall be opened before sufficient cooling time has elapsed; this to avoid the risk of spontaneous ignition of oil vapour when air is admitted.
- 4 Normal ratings (pressures, temperatures, speeds, etc.) shall be durably marked.
- 5 Operate the unit only for the intended purpose and within its rated limits (pressure, temperature, speeds, etc.).
- 6 The machinery and equipment shall be kept clean, i.e. as free as possible from oil, dust or other deposits.
- 7 To prevent an increase in working temperature, inspect and clean heat transfer surfaces (cooler fins, intercoolers, water jackets, etc.) regularly. See the **Preventive maintenance schedule for the compressor**.
- 8 All regulating and safety devices shall be maintained with due care to ensure that they function properly. They may not be put out of action.
- 9 Care shall be taken to avoid damage to safety valves and other pressure-relief devices, especially to avoid plugging by paint, oil coke or dirt accumulation, which could interfere with the functioning of the device.
- 10 Pressure and temperature gauges shall be checked regularly with regard to their accuracy. They shall be replaced whenever outside acceptable tolerances.
- 11 Safety devices shall be tested as described in the maintenance schedule of the instruction manual to determine that they are in good operating condition. See the **Preventive maintenance schedule for the compressor**.
- 12 Mind the markings and information labels on the unit.
- 13 In the event the safety labels are damaged or destroyed, they must be replaced to ensure operator safety.
- 14 Keep the work area neat. Lack of order will increase the risk of accidents.
- 15 When working on the unit, wear safety clothing. Depending on the kind of activities these are: safety glasses, ear protection, safety helmet (including visor), safety gloves, protective clothing, safety shoes. Do not wear the hair long and loose (protect long hair with a hairnet), or wear loose clothing or jewelry.
- 16 Take precautions against fire. Handle fuel, oil and anti-freeze with care because they are inflammable substances. Do not smoke or approach with naked flame when handling such substances. Keep a fire-extinguisher in the vicinity.

SAFETY DURING TRANSPORT AND INSTALLATION

To lift a unit, all loose or pivoting parts, e.g. doors and towbar, shall first be securely fastened.

Do not attach cables, chains or ropes directly to the lifting eye; apply a crane hook or lifting shackle meeting local safety regulations. Never allow sharp bends in lifting cables, chains or ropes.

Helicopter lifting is not allowed.

It is strictly forbidden to dwell or stay in the risk zone under a lifted load. Never lift the unit over people or residential areas. Lifting acceleration and retardation shall be kept within safe limits.

1 Before towing the unit:

- ascertain that the pressure vessel(s) is (are) depressurized,
- check the towbar, the brake system and the towing eye. Also check the coupling of the towing vehicle,
- check the towing and brake capability of the towing vehicle,
- check that the towbar, jockey wheel or stand leg is safely locked in the raised position,
- ascertain that the towing eye can swivel freely on the hook,
- check that the wheels are secure and that the tyres are in good condition and inflated correctly,
- connect the signalisation cable, check all lights and connect the pneumatic brake couplers,
- attach the safety break-away cable or safety chain to the towing vehicle,
- remove wheel chocks, if applied, and disengage the parking brake.

- 2 To tow a unit use a towing vehicle of ample capacity. Refer to the documentation of the towing vehicle.
- 3 If the unit is to be backed up by the towing vehicle, disengage the overrun brake mechanism (if it is not an automatic mechanism).
- 4 Never exceed the maximum towing speed of the unit (mind the local regulations).
- 5 Place the unit on level ground and apply the parking brake before disconnecting the unit from the towing vehicle. Unclip the safety break-away cable or safety chain. If the unit has no parking brake or jockey wheel, immobilize the unit by placing chocks in front of and/or behind the wheels. When the towbar can be positioned vertically, the locking device must be applied and kept in good order.
- 6 To lift heavy parts, a hoist of ample capacity, tested and approved according to local safety regulations, shall be used.
- 7 Lifting hooks, eyes, shackles, etc., shall never be bent and shall only have stress in line with their design load axis. The capacity of a lifting device diminishes when the lifting force is applied at an angle to its load axis.
- 8 For maximum safety and efficiency of the lifting apparatus all lifting members shall be applied as near to perpendicular as possible. If required, a lifting beam shall be applied between hoist and load.
- 9 Never leave a load hanging on a hoist.
- 10 A hoist has to be installed in such a way that the object will be lifted perpendicular. If that is not possible, the necessary precautions must be taken to prevent load-swinging, e.g. by using two hoists, each at approximately the same angle not exceeding 30° from the vertical.

- 11 Locate the unit away from walls. Take all precautions to ensure that hot air exhausted from the engine and driven machine cooling systems cannot be recirculated. If such hot air is taken in by the engine or driven machine cooling fan, this may cause overheating of the unit; if taken in for combustion, the engine power will be reduced.

SAFETY DURING USE AND OPERATION

- 1 When the unit has to operate in a fire-hazardous environment, each engine exhaust has to be provided with a spark arrestor to trap incendiary sparks.
- 2 The exhaust contains carbon monoxide which is a lethal gas. When the unit is used in a confined space, conduct the engine exhaust to the outside atmosphere by a pipe of sufficient diameter; do this in such a way that no extra back pressure is created for the engine. If necessary, install an extractor. Observe any existing local regulations. Make sure that the unit has sufficient air intake for operation. If necessary, install extra air intake ducts.
- 3 When operating in a dust-laden atmosphere, place the unit so that dust is not carried towards it by the wind. Operation in clean surroundings considerably extends the intervals for cleaning the air intake filters and the cores of the coolers.
- 4 Close the compressor air outlet valve before connecting or disconnecting a hose. Ascertain that a hose is fully depressurized before disconnecting it. Before blowing compressed air through a hose or air line, ensure that the open end is held securely, so that it cannot whip and cause injury.

- 5 The air line end connected to the outlet valve must be safeguarded with a safety cable, attached next to the valve.
- 6 No external force may be exerted on the air outlet valves, e.g. by pulling on hoses or by installing auxiliary equipment directly to a valve, e.g. a water separator, a lubricator, etc. Do not step on the air outlet valves.
- 7 Never move a unit when external lines or hoses are connected to the outlet valves, to avoid damage to valves, manifold and hoses.
- 8 Do not use compressed air from any type of compressor, without taking extra measures, for breathing purposes as this may result in injury or death. For breathing air quality, the compressed air must be adequately purified according to local legislation and standards. Breathing air must always be supplied at stable, suitable pressure.
- 9 Distribution pipework and air hoses must be of correct diameter and suitable for the working pressure. Never use frayed, damaged or deteriorated hoses. Replace hoses and flexibles before the lifetime expires. Use only the correct type and size of hose end fittings and connections.
- 10 If the compressor is to be used for sand-blasting or will be connected to a common compressed-air system, fit an appropriate non-return valve (check valve) between compressor outlet and the connected sand-blasting or compressed-air system. Observe the right mounting position/direction.
- 11 Before removing the oil filler plug, ensure that the pressure is released by opening an air outlet valve.
- 12 Never remove a filler cap of the cooling water system of a hot engine. Wait until the engine has sufficiently cooled down.
- 13 Never refill fuel while the unit is running, unless otherwise stated in the Atlas Copco Instruction Book. Keep fuel away from hot parts such as air outlet pipes or the engine exhaust. Do not smoke when fuelling. When fuelling from an automatic pump, an earthing cable should be connected to the unit to discharge static electricity. Never spill nor leave oil, fuel, coolant or cleansing agent in or around the unit.
- 14 All doors shall be shut during operation so as not to disturb the cooling air flow inside the bodywork and/or render the silencing less effective. A door should be kept open for a short period only e.g. for inspection or adjustment.
- 15 Periodically carry out maintenance works according to the maintenance schedule.
- 16 Stationary housing guards are provided on all rotating or reciprocating parts not otherwise protected and which may be hazardous to personnel. Machinery shall never be put into operation, when such guards have been removed, before the guards are securely reinstalled.
- 17 Noise, even at reasonable levels, can cause irritation and disturbance which, over a long period of time, may cause severe injuries to the nervous system of human beings. When the sound pressure level, at any point where personnel normally has to attend, is:
 - below 70 dB(A): no action needs to be taken,
 - above 70 dB(A): noise-protective devices should be provided for people continuously being present in the room,
 - below 85 dB(A): no action needs to be taken for occasional visitors staying a limited time only,
 - above 85 dB(A): room to be classified as a noise-hazardous area and an obvious warning shall be placed permanently at each entrance to alert people entering the room, for even relatively short times, about the need to wear ear protectors,
 - above 95 dB(A): the warning(s) at the entrance(s) shall be completed with the recommendation that also occasional visitors shall wear ear protectors,
 - above 105 dB(A): special ear protectors that are adequate for this noise level and the spectral composition of the noise shall be provided and a special warning to that effect shall be placed at each entrance.
- 18 Insulation or safety guards of parts the temperature of which can be in excess of 80 °C (175 °F) and which may be accidentally touched by personnel shall not be removed before the parts have cooled to room temperature.
- 19 Never operate the unit in surroundings where there is a possibility of taking in flammable or toxic fumes.
- 20 If the working process produces fumes, dust or vibration hazards, etc., take the necessary steps to eliminate the risk of personnel injury.
- 21 When using compressed air or inert gas to clean down equipment, do so with caution and use the appropriate protection, at least safety glasses, for the operator as well as for any bystander. Do not apply compressed air or inert gas to your skin or direct an air or gas stream at people. Never use it to clean dirt from your clothes.
- 22 When washing parts in or with a cleaning solvent, provide the required ventilation and use appropriate protection such as a breathing filter, safety glasses, rubber apron and gloves, etc.

- 23 Safety shoes should be compulsory in any workshop and if there is a risk, however small, of falling objects, wearing of a safety helmet should be included.
- 24 If there is a risk of inhaling hazardous gases, fumes or dust, the respiratory organs must be protected and depending on the nature of the hazard, so must the eyes and skin.
- 25 Remember that where there is visible dust, the finer, invisible particles will almost certainly be present too; but the fact that no dust can be seen is not a reliable indication that dangerous, invisible dust is not present in the air.
- 26 Never operate the unit at pressures or speeds below or in excess of its limits as indicated in the technical specifications.

SAFETY DURING MAINTENANCE AND REPAIR

Maintenance, overhaul and repair work shall only be carried out by adequately trained personnel; if required, under supervision of someone qualified for the job.

- 1 Use only the correct tools for maintenance and repair work, and only tools which are in good condition.
- 2 Parts shall only be replaced by genuine Atlas Copco replacement parts.
- 3 All maintenance work, other than routine attention, shall only be undertaken when the unit is stopped. Steps shall be taken to prevent inadvertent starting. In addition, a warning sign bearing a legend such as "work in progress; do not start" shall be attached to the starting equipment.
On engine-driven units the battery shall be disconnected and removed or the terminals covered by insulating caps.
On electrically driven units the main switch shall be locked in open position and the fuses shall be taken out. A warning sign bearing a legend such as "work in progress; do not supply voltage" shall be attached to the fuse box or main switch.
- 4 Before dismantling any pressurized component, the compressor or equipment shall be effectively isolated from all sources of pressure and the entire system shall be relieved of pressure. Do not rely on non-return valves (check valves) to isolate pressure systems. In addition, a warning sign bearing a legend such as "work in progress; do not open" shall be attached to each of the outlet valves.
- 5 Prior to stripping an engine or other machine or undertaking major overhaul on it, prevent all movable parts from rolling over or moving.

- 6 Make sure that no tools, loose parts or rags are left in or on the machine. Never leave rags or loose clothing near the engine air intake.
- 7 Never use flammable solvents for cleaning (fire-risk).
- 8 Take safety precautions against toxic vapours of cleaning liquids.
- 9 Never use machine parts as a climbing aid.
- 10 Observe scrupulous cleanliness during maintenance and repair. Keep away dirt, cover the parts and exposed openings with a clean cloth, paper or tape.
- 11 Never weld on or perform any operation involving heat near the fuel or oil systems. Fuel and oil tanks must be completely purged, e.g. by steam-cleaning, before carrying out such operations. Never weld on, or in any way modify, pressure vessels. Disconnect the alternator cables during arc welding on the unit.
- 12 Support the towbar and the axle(s) securely if working underneath the unit or when removing a wheel. Do not rely on jacks.
- 13 Do not remove any of, or tamper with, the sound-damping material. Keep the material free of dirt and liquids such as fuel, oil and cleansing agents. If any sound-damping material is damaged, replace it to prevent the sound pressure level from increasing.
- 14 Use only lubricating oils and greases recommended or approved by Atlas Copco or the machine manufacturer. Ascertain that the selected lubricants comply with all applicable safety regulations, especially with regard to explosion or fire-risk and the possibility of decomposition or generation of hazardous gases. Never mix synthetic with mineral oil.

- 15 Protect the engine, alternator, air intake filter, electrical and regulating components, etc., to prevent moisture ingress, e.g. when steam-cleaning.
- 16 When performing any operation involving heat, flames or sparks on a machine, the surrounding components shall first be screened with non-flammable material.
- 17 Never use a light source with open flame for inspecting the interior of a machine.
- 18 When repair has been completed, the machine shall be barred over at least one revolution for reciprocating machines, several revolutions for rotary ones to ensure that there is no mechanical interference within the machine or driver. Check the direction of rotation of electric motors when starting up the machine initially and after any alteration to the electrical connection(s) or switch gear, to check that the oil pump and the fan function properly.
- 19 Maintenance and repair work should be recorded in an operator's logbook for all machinery. Frequency and nature of repairs can reveal unsafe conditions.
- 20 When hot parts have to be handled, e.g. shrink fitting, special heat-resistant gloves shall be used and, if required, other body protection shall be applied.
- 21 When using cartridge type breathing filter equipment, ascertain that the correct type of cartridge is used and that its useful service life is not surpassed.
- 22 Make sure that oil, solvents and other substances likely to pollute the environment are properly disposed of.
- 23 Before clearing the unit for use after maintenance or overhaul, check that operating pressures, temperatures and speeds are correct and that the control and shutdown devices function correctly.

TOOL APPLICATIONS SAFETY

Apply the proper tool for each job. With the knowledge of correct tool use and knowing the limitations of tools, along with some common sense, many accidents can be prevented.

Special service tools are available for specific jobs and should be used when recommended. The use of these tools will save time and prevent damage to parts.

SPECIFIC SAFETY PRECAUTIONS

Batteries

When servicing batteries, always wear protecting clothing and glasses.

- 1 The electrolyte in batteries is a sulphuric acid solution which is fatal if it hits your eyes, and which can cause burns if it contacts your skin. Therefore, be careful when handling batteries, e.g. when checking the charge condition.
- 2 Install a sign prohibiting fire, open flame and smoking at the post where batteries are being charged.
- 3 When batteries are being charged, an explosive gas mixture forms in the cells and might escape through the vent holes in the plugs. Thus an explosive atmosphere may form around the battery if ventilation is poor, and can remain in and around the battery for several hours after it has been charged. Therefore:
 - never smoke near batteries being, or having recently been, charged,
 - never break live circuits at battery terminals, because a spark usually occurs.
- 4 When connecting an auxiliary battery (AB) in parallel to the unit battery (CB) with booster cables: connect the + pole of AB to the + pole of CB, then connect the - pole of CB to the mass of the unit. Disconnect in the reverse order.

Pressure vessels

(according to directive 87/404/EEC annex II § 2)

Maintenance/installation requirements:

- 1 The vessel can be used as pressure vessel or as separator and is designed to hold compressed air for the following application:
 - pressure vessel for compressor,
 - medium AIR/OIL,and operates as detailed on the data plate of the vessel:
 - the maximum working pressure p_s in bar (psi),
 - the maximum working temperature T_{max} in °C (°F),
 - the minimum working temperature T_{min} in °C (°F),
 - the capacity of the vessel V in l (US gal, Imp gal, cu.ft).
- 2 The pressure vessel is only to be used for the applications as specified above and in accordance with the technical specifications. Safety reasons prohibit any other applications.
- 3 National legislation requirements with respect to re-inspection must be complied with.
- 4 No welding or heat treatment of any kind is permitted to those vessel walls which are exposed to pressure.
- 5 The vessel is provided and may only be used with the required safety equipment such as manometer, overpressure control devices, safety valve, etc.
- 6 Draining of condensate shall be performed regularly when vessel is in use.
- 7 Installation, design and connections should not be changed.
- 8 Bolts of cover and flanges may not be used for extra fixation.

Safety valves

All adjustments or repairs are to be done by an authorized representative of the valve supplier (see also **Preventive maintenance schedule for the compressor**).

Leading particulars

DESCRIPTION OF SAFETY PICTOGRAMS USED IN THIS MANUAL



This symbol draws your attention to dangerous situations. The operation concerned may endanger persons and cause injuries.



This symbol is followed by supplementary information.

GENERAL DESCRIPTION

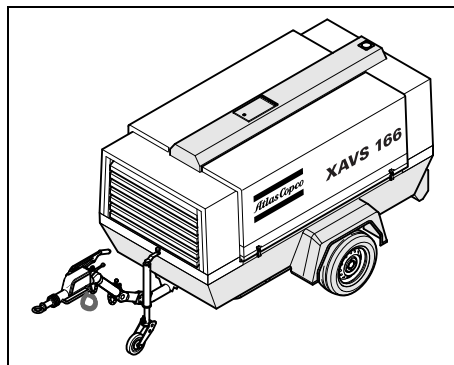

The compressors type XAHS 146 Dd, XATS 156 Dd, XA(S) 186 Dd, XAVS 166 Dd and XAHS 186 Dd are silenced, single-stage, oil-injected screw compressors, built for a nominal effective working pressure, ranging from 7 bar (102 psi) up to 12 bar (175 psi) (see chapter **Technical specifications**).

Engine

The compressors are driven by a liquid-cooled diesel engine.

The engine's power is transmitted to the compressor through a heavy-duty coupling.

Compressor

The compressor casing houses two screw-type rotors, mounted on ball and roller bearings. The male rotor, driven by the engine, drives the female rotor. The element delivers pulsation-free air.

Injected oil is used for sealing, cooling and lubricating purposes.

Compressor oil system

The oil is boosted by air pressure. The system has no oil pump.

The oil is removed from the air, in the air/oil vessel at first by centrifugal force, secondly by the oil separator element.

The vessel is provided with an oil level indicator.

Regulation

The compressor is provided with a continuous regulating system and a blow-down valve which is integrated in the unloader assembly. The valve is closed during operation by air receiver pressure and opens by air receiver pressure via the compressor element when the compressor is stopped.

When the air consumption increases, the air receiver pressure will decrease and vice versa.

This receiver pressure variation is sensed by the regulating valve which, by means of control air to the unloader and engine speed regulator, matches the air output to the air consumption. The air receiver pressure is maintained between the pre-selected working pressure and the corresponding unloading pressure.

Cooling system

The engine is equipped with a liquid cooler and intercooler. All compressors are equipped with an oil cooler.

The cooling air is generated by a fan, driven by the engine.

Safety devices

A thermal shut-down switch protects the compressor against overheating. The air receiver is provided with a safety valve.

The engine is equipped with low oil pressure and high oil temperature shut-down switches.

Frame and axle

The compressor/engine unit is supported by rubber buffers in the frame.

The standard unit has a non-adjustable towbar with a towing eye.

As an option the unit can be equipped with an adjustable towbar, an overrun and parking brake and towing eyes type DIN, ball, ITA, GB, NATO, AC (France), (see chapter **Available options**).

The braking system consists of an integrated parking brake and overrunbrake. When driving backwards the overrunbrake is not engaged automatically.

Bodywork

The bodywork has openings at the shaped front and rear end for the intake and outlet of cooling air and hinged door for maintenance and service operations. The bodywork is internally lined with sound-absorbing material.

Lifting eye

A lifting eye is accessible when the small door at the top of the unit is unlocked.

Control panel

The control panel grouping the air pressure gauge, control switch etc., is placed in the center at the rear end.

Data plate

The compressor is furnished with a data plate showing the product code, the unit number and the working pressure (see chapter **Data plate**).

Serial number

The serial number is located on the right-hand side towards the front on the upper edge of the frame and also on the data plate.

Main Parts

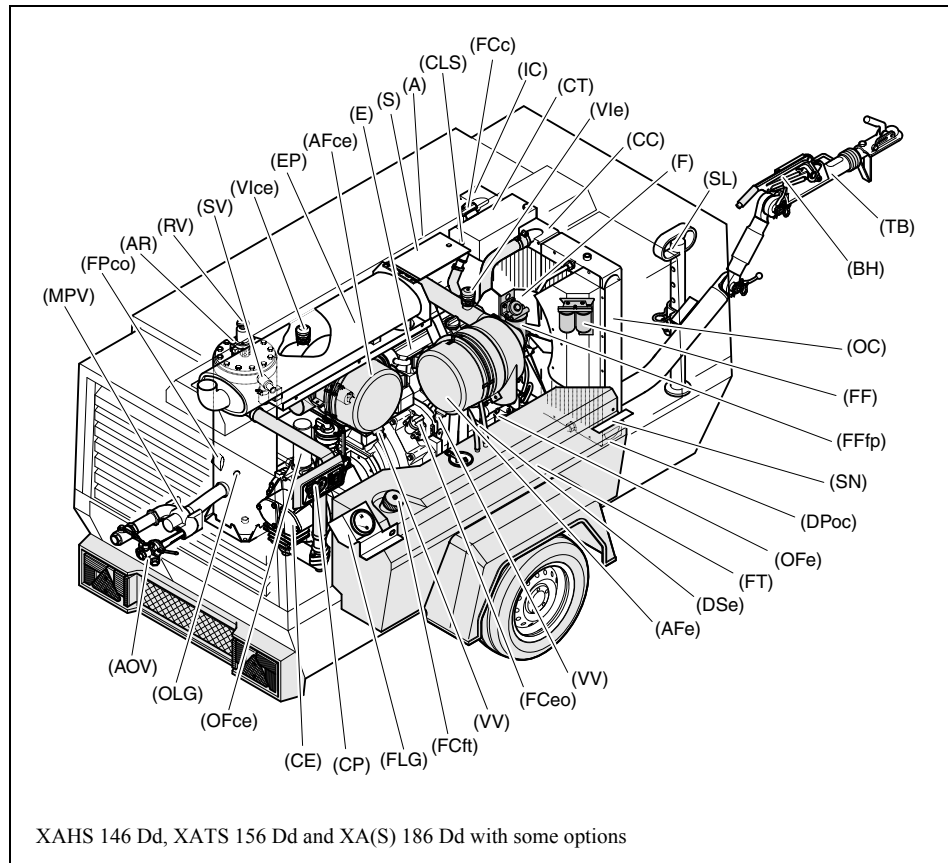

Reference	Name
A	Alternator
AFce	Air Filter (compressor element)
AFe	Air Filter (engine)
AOV	Air Outlet Valves
AR	Air Receiver
BH	Brake Handle
CC	Coolant Cooler
CE	Compressor Element
CLS	Coolant Level Switch
CP	Control Panel
CT	Coolant Tank
DPoc	Drain Plug Oil Cooler
DSe	Engine Oil Level Dipstick
E	Engine
EP	Exhaust Pipe
F	Fan
FCeo	Filler Cap (engine oil)
FCft	Filler Cap (fuel tank)
FCc	Filler Cap (coolant)
FF	Fuel Filter
FFfp	Fuel Prefilter
FLG	Fuel Level Gauge
FPco	Filler Plug (compressor oil)
FT	Fuel Tank

Reference	Name
IC	Intercooler
MPV	Minimum Pressure Valve
OC	Oil Cooler
OFce	Oil Filter (compressor element)
OFe	Oil Filter (engine)
OLG	Oil Level Gauge (compressor element)
RV	Regulating Valve
S	Starting Motor
SL	Support Leg
SN	Serial Number
SV	Safety Valve
TB	Towbar
Vlce	Vacuum Indicator (compressor element)
Vle	Vacuum Indicator (engine)
VV	Vacuator Valve

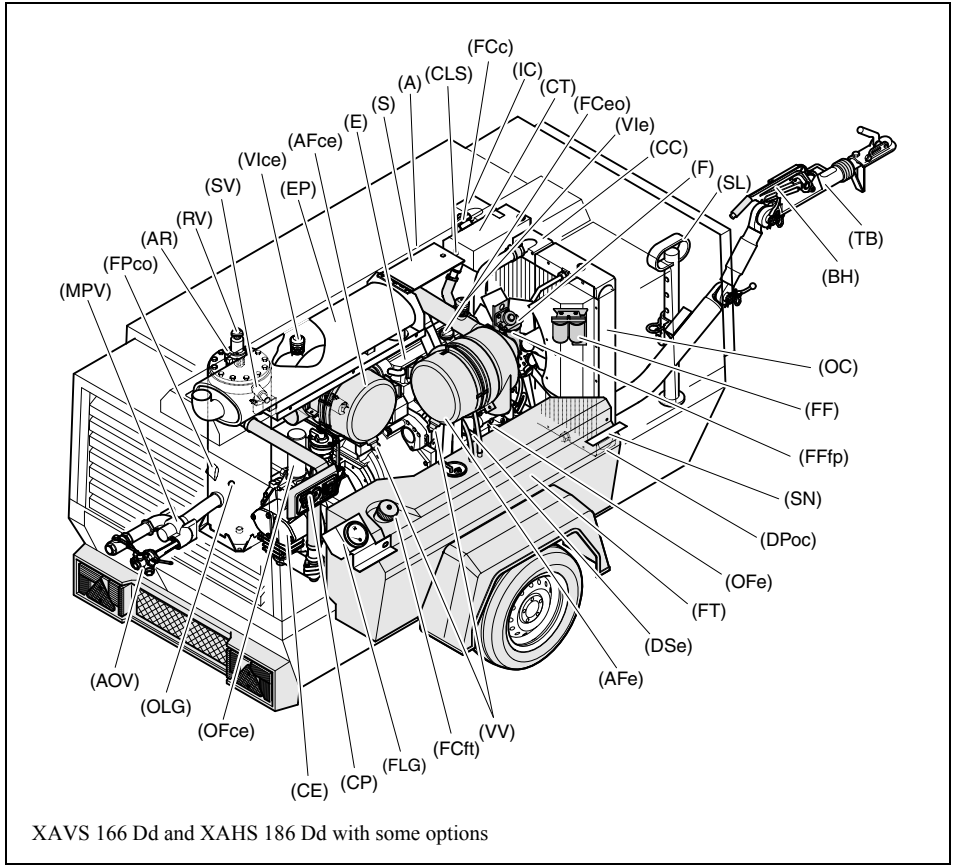

XAVS 166 Dd and XAHS 186 Dd with some options

Reference	Name
A	Alternator
AFce	Air Filter (compressor element)
AFe	Air Filter (engine)
AOV	Air Outlet Valves
AR	Air Receiver
BH	Brake Handle
CC	Coolant Cooler
CE	Compressor Element
CLS	Coolant Level Switch
CP	Control Panel
CT	Coolant Tank
DPoc	Drain Plug Oil Cooler
DSe	Engine Oil Level Dipstick
E	Engine
EP	Exhaust Pipe
F	Fan
FCeo	Filler Cap (engine oil)
FCft	Filler Cap (fuel tank)
FCc	Filler Cap (coolant)
FF	Fuel Filter
FFfp	Fuel Prefilter
FLG	Fuel Level Gauge
FPco	Filler Plug (compressor oil)
FT	Fuel Tank

Reference	Name
IC	Intercooler
MPV	Minimum Pressure Valve
OC	Oil Cooler
OFce	Oil Filter (compressor element)
OFe	Oil Filter (engine)
OLG	Oil Level Gauge (compressor element)
RV	Regulating Valve
S	Starting Motor
SL	Support Leg
SN	Serial Number
SV	Safety Valve
TB	Towbar
Vlce	Vacuum Indicator (compressor element)
Vle	Vacuum Indicator (engine)
VV	Vacuator Valve

COMPRESSOR REGULATING SYSTEM

OVERVIEW (LOAD CONDITION)

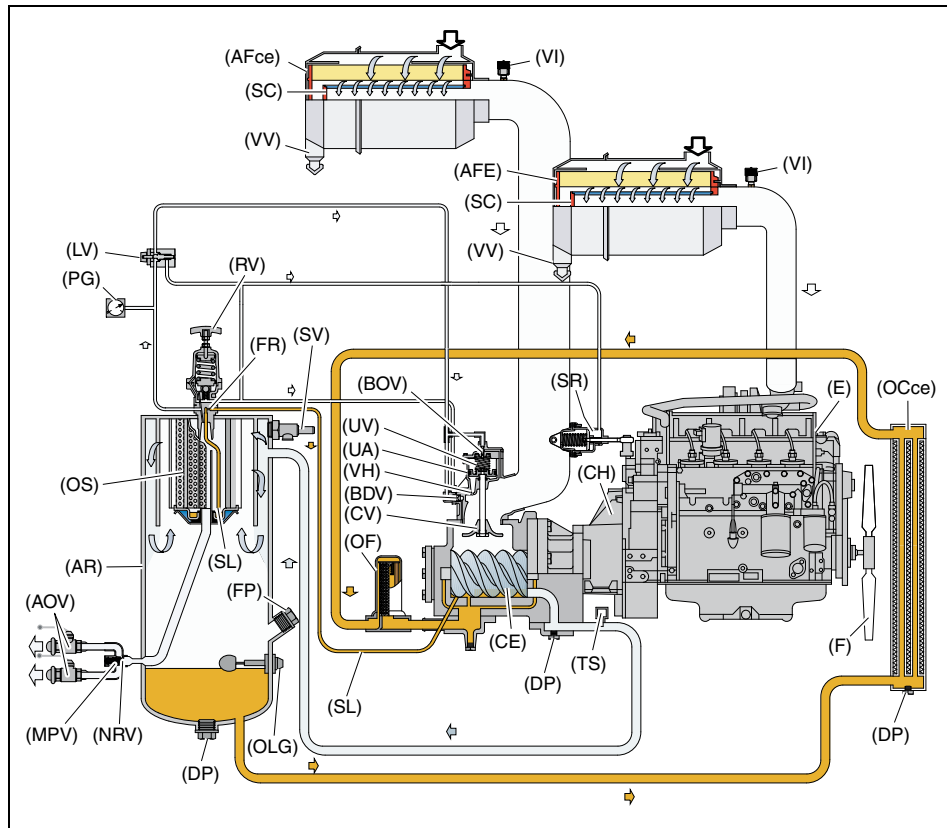

Reference	Name
AFce	Air Filter (compressor element)
AFe	Air Filter (engine)
AOV	Air Outlet Valves
AR	Air Receiver
BDV	Blow Down Valve
BOV	Blow Off Valve
CE	Compressor Element
CH	Coupling Housing
CV	Check Valve
DP	Drain Plug
E	Engine
F	Fan
FP	Filler Plug
FR	Flow Restrictor
LV	Loading Valve
MPV	Minimum Pressure Valve
NRV	Non Return Valve
OCce	Oil Cooler (compressor element)
OF	Oil Filter
OLG	Oil Level Gauge
OS	Oil Separator

Reference	Name
PG	Pressure Gauge
RV	Regulating Valve
SC	Safety Cartridge (option)
SL	Scavenge Line
SR	Speed Regulator
SV	Safety Valve
TS	Temperature Switch
UA	Unloader Assembly
UV	Unloader Valve
VH	Vent Hole
VI	Vacuum Indicator
VV	Vacuator Valve

AIR FLOW

The system comprises:

AF	Air filter
AR/OS	Air receiver/oil separator
CE	Compressor element
UA/UV	Unloader assembly with unloader valve
BDV	Blow-down valve
LV	Loading valve

Air drawn through the airfilter (AFce) into the compressor element (CE) is compressed. At the element outlet, compressed air and oil pass into the air receiver/oil separator (AR/OS).

The check valve (CV) prevents blow-back of compressed air when the compressor is stopped. In the air receiver/oil separator (AR/OS), most of the oil is removed from the air/oil mixture; the remaining oil is removed by the separator element.

The oil collects in the receiver and on the bottom of the separator element.

The air leaves the receiver via a minimum pressure valve (MPV) which prevents the receiver pressure from dropping below the minimum working pressure (specified in section **Limitations**), even when the air outlet valves are open. This ensures adequate oil injection and prevents oil consumption.

A temperature switch (TS) and a working pressure gauge (WPG) are comprised in the system.

A blow-down valve (BDV) is fitted in the unloader assembly to automatically depressurise the air receiver (AR) when the compressor is stopped.

OIL SYSTEM

The system comprises:

AR/OS	Air receiver/oil separator
OC	Oil cooler
OF	Oil filter

The lower part of the air receiver (AR) serves as oil tank.

Air pressure forces the oil from the air receiver/oil separator (AR/OS) through the oil cooler (OCce) and oil filter (OF) to the compressor element (CE).

The compressor element has an oil gallery in the bottom of its casing. The oil for rotor lubrication, cooling and sealing is injected through holes in the gallery.

Lubrication of the bearings is ensured by oil injected into the bearing housings.

The injected oil, mixed with the compressed air, leaves the compressor element and re-enters the air receiver, where it is separated from the air as described in section **Air flow**. The oil that collects in the bottom of the oil separator element is returned to the system through scavenging line (SL), which is provided with a flow restrictor (FR).

The oil filter by-pass valve opens when the pressure drop over the filter is above normal because of a clogged filter. The oil then by-passes the filter without being filtered. For this reason, the oil filter must be replaced at regular intervals (see section **Preventive maintenance schedule for the compressor**).

CONTINUOUS REGULATING SYSTEM

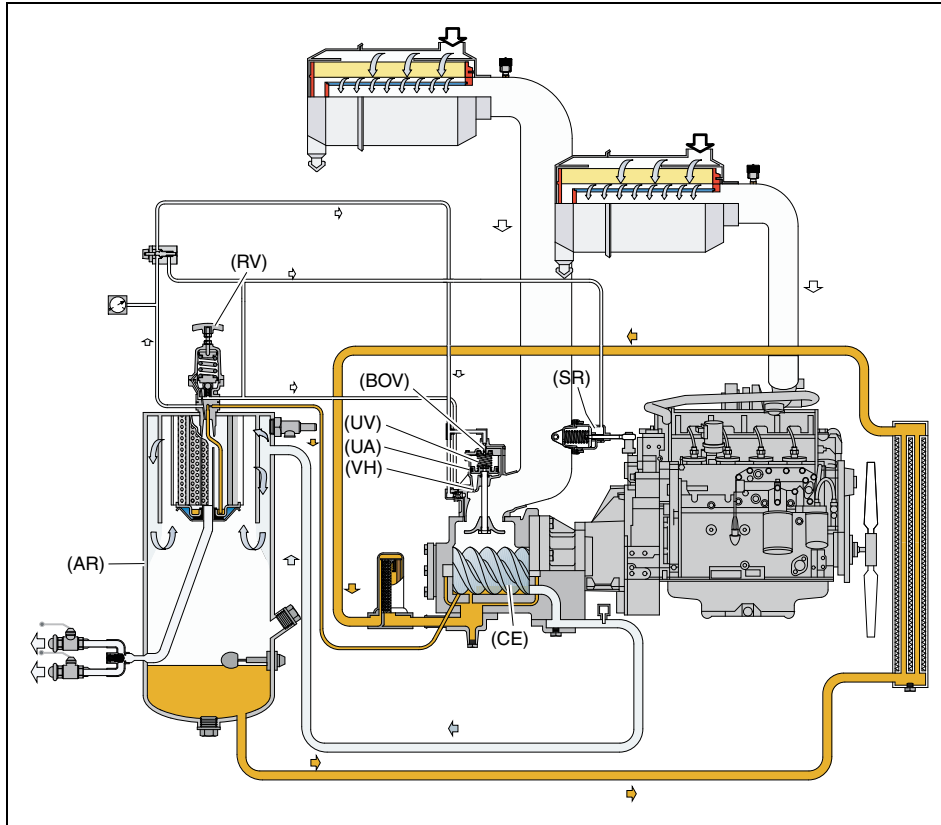

The system comprises:

RV	Regulating valve
UA	Unloader assembly
SR	Speed regulator

The compressor is provided with a continuous regulating system. This system is provided with a blow-down valve which is integrated in the unloader assembly (UA). The valve is closed during operation by air receiver pressure and opens by air receiver pressure via the compressor element when the compressor is stopped.

When the air consumption increases, the air receiver pressure will decrease and vice versa. This receiver pressure variation is sensed by the regulating valve which, by means of control air to the unloader, matches the air output to the air consumption. The air receiver pressure is maintained between the pre-selected working pressure and the corresponding unloading pressure.

When starting the compressor, the unloader valve (UV) is kept open by spring force, the engine runs at maximum speed. The compressor element (CE) takes in air and pressure builds up in the receiver (AR).

The air output is controlled from maximum output (100%) to no output (0%) by:

1. Speed control of the engine between maximum load speed and unloading speed (the output of a screw compressor is proportional to the rotating speed).
2. Air inlet throttling.
3. Blow off valve (BOV).

If the air consumption is equal to or exceeds the maximum air output, the engine speed is held at maximum load speed and the unloading valve is fully open.

If the air consumption is less than the maximum air output, the regulating valve supplies control air to unloader valve (UV) to reduce the air output and holds air receiver pressure between the normal working pressure and the corresponding unloading pressure of approx. 1.5 bar (22 psi) above the normal working pressure.

When the air consumption is resumed, the blow off valve (BOV) closes and the unloader valve (UV) gradually opens the air intake and the speed regulator (SR) increases the engine speed.

The construction of the regulating valve (RV) is such that any increase (decrease) of the air receiver pressure above the pre-set valve opening pressure results in a proportional increase (decrease) of the control pressure to the unloading valve and the speed regulator.

Part of the control air is vented to atmosphere, and any condensate discharged, through the vent holes (VH).

ELECTRICAL SYSTEM

All compressors are equipped with a negative earthed system.

(9822 0893 12)

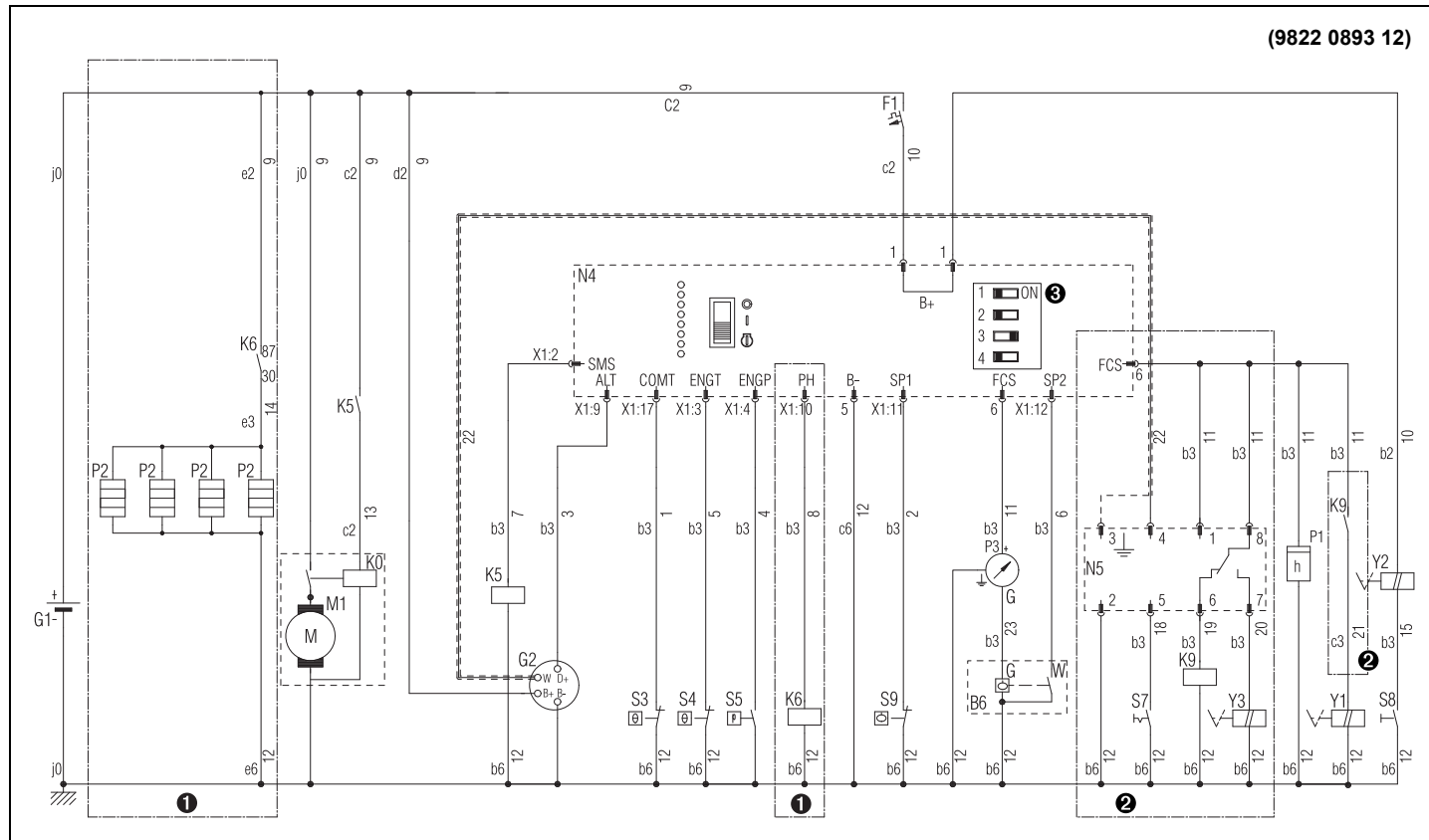

Reference	Name
1	To be used with Cold Start Option.
2	To be used with Refinery Equipment.
3	Position of DIP-switches.
B6	Fuel Level Sensor
F1	Circuit Breaker
G1	Battery 12V
G2	Charging Alternator
K0	Starter Solenoid
K5	Auxiliary Starter Relay
K6	Cold Start Relay
K9	Overspeed Relay
M1	Starter Motor
N4	Control Module
N5	Overspeed Control Module
P1	Hourmeter
P2	Glowplug
P3	Fuel Level Gauge
S3	Compressor Temperature Switch
S4	Engine Temperature Switch

Reference	Name
S5	Engine Low Oil Pressure Switch
S7	Overspeed Control Test Switch
S8	Push Button
S9	Coolant Level Switch
X1	Module Connector
Y1	Fuel Stop Solenoid
Y2	Excess Fuel Provider
Y3	Overspeed Solenoid



For correct functioning of the module, the dip switches at the back of the module should be positioned as follows.

DIP SWITCHES FOR XAHS 146 Dd, XATS 156 Dd AND XA(S) 186 Dd

Standard (no coldstart)

With coldstart option

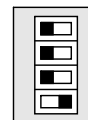

Not used
Preheat-Coldstart
Low fuel level
Low coolant level

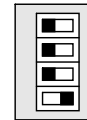

DIP SWITCHES FOR XAVS 166 Dd AND XAHS 186 Dd

Standard (no coldstart)



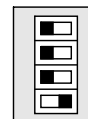



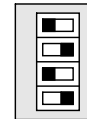





With coldstart option

























Not used
Preheat-Coldstart
Low fuel level
Low coolant level



MARKINGS AND INFORMATION LABELS

	Compressor outlet temperature too high.
	Compressor outlet temperature.
	Compressor outlet pressure.
	Dangerous outlet gases.
	Danger, heat flat.
	Electrocution hazard.
 PAROIL M	Atlas Copco mineral compressor oil.
 PAROIL S	Atlas Copco synthetic compressor oil.
 PAROIL SAE 15W40	Atlas Copco mineral engine oil.
	Manual.
	Read the instruction manual before working on the battery.
	Reset fuse.

	On / off button.
	Hours, time.
	Prohibition to open air valves without connected hoses.
	Compressor loaded.
	Runlamp.
	Airfilter.
	Compressor temperature too high.
	Rotation direction.
	Inlet.
	Outlet.
	Compressor oil drain.
	Read the instruction manual before starting.

	Service every 24 hours.
	Warning! Part under pressure.
	Do not stand on outlet valves.
	Start-Stop indication of switch.
	Do not run the compressor with open doors.
	Lifting permitted.
	Use diesel fuel only.
4.75 bar (69 psi)	Tyre pressure.
	Sound power level in accordance with Directive 2000/14/EC (expressed in dB (A)).
	Sound power level in accordance with Directive 2000/14/EC (expressed in dB (A)).
	Sound power level in accordance with Directive 2000/14/EC (expressed in dB (A)).
	Horizontal towbar position required in case of coupling.

Operating instructions

PARKING, TOWING AND LIFTING INSTRUCTIONS

Safety precautions



Never load the vehicles in excess of the permissible total weight.

Never overstress the coupling or suspension system due to reckless or aggressive driving or mishandling. Avoid subjecting the axles to any impacts or jolting. Adapt your driving speed at all times to the road conditions.

Ensure that wheels and tyres are not misaligned or out-of-balance.

Only use the jacking points indicated by Atlas Copco.

The operator is expected to apply all relevant safety precautions, including those mentioned on the pages 7 - 13 of this book.

Attention:



Before putting the compressor in to use, check the brake system as described in section Brake (= option) adjustment.

After the first 100 km travel - Yearly or every 5000 km:

Check and retighten the wheel nuts and towbar bolts to the specified torque. See section Height adjustment and section Torque values.

Check the brake adjustment. See section Brake (= option) adjustment.

PARKING INSTRUCTIONS

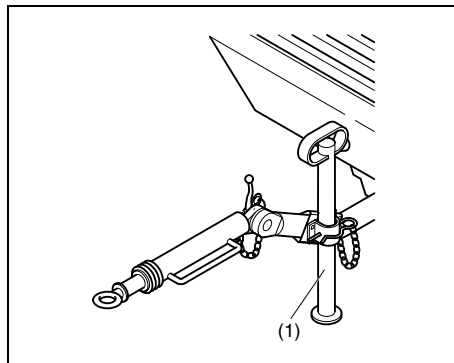

Non-adjustable towbar with standard support leg without brakes

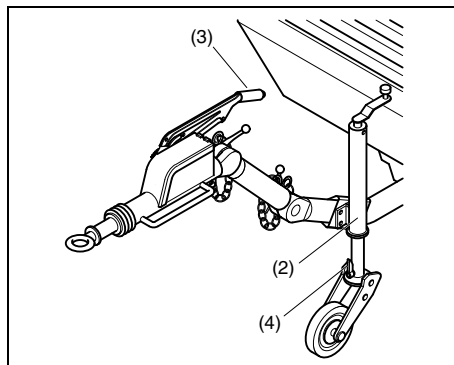

Adjustable towbar with jockey wheel and brakes

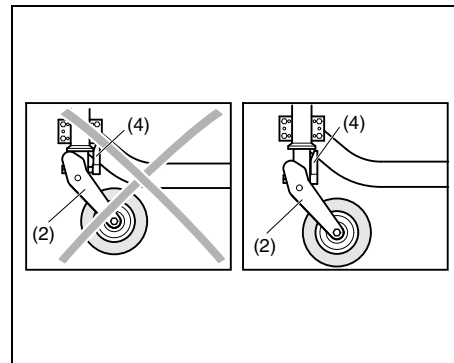

Parking position of jockey wheel



It must be noted that, with the parking brake activated, the vehicle can roll back about 30 cm until the braking force takes full effect.

When parking a compressor, secure support leg (1) or jockey wheel (2) to support the compressor in a level position. Be sure that the jockey wheel (2) is blocked by the blocking pin (4).

Apply parking brake by pulling parking brake handle (3) upwards. Place the compressor as level as possible; however, it can be operated temporarily in an out-of-level position not exceeding 15°. If the compressor is parked on sloping ground, immobilize the compressor by placing wheel chocks (available as option) in front of or behind the wheels.

TOWING INSTRUCTIONS

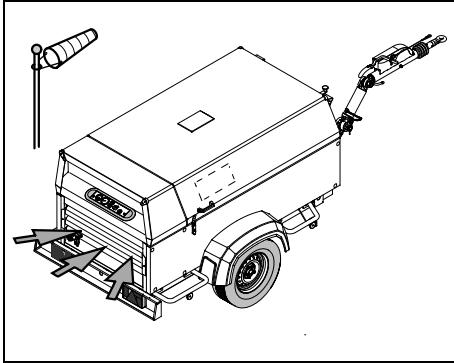

Locate the rear-end of the compressor upwind, away from contaminated wind-streams and walls. Avoid recirculation of exhaust air from the engine. This causes overheating and engine power decrease.

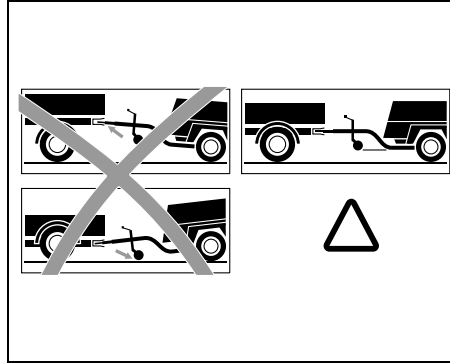

Label on towbar

Inspections, prior to each run

- Check tyre pressure and tyre condition
- Check wheel fixation
- Check screwed joints on firm seating.
- Check functioning of lighting and braking systems (option)
- The jockey wheel must be parallel to the direction of travel at all times.
- Inspect the coupling. The ball joint must fully enclose the ball and be locked.
- At height adjustable towing facility (option), check the joint connection for a tight fit.

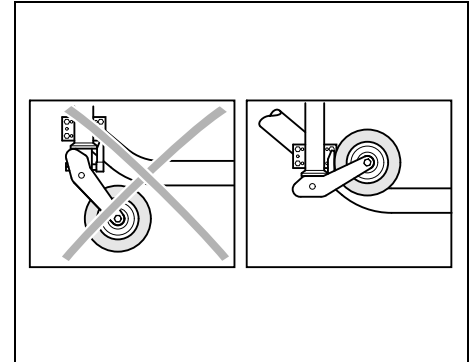
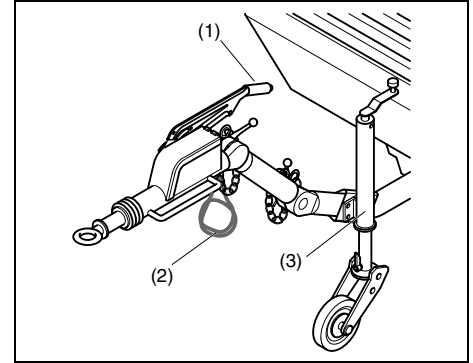



Before towing the compressor, ensure that the towing equipment of the vehicle matches the towing eye or ball connector and ensure that the service doors are closed and locked properly.

For both non-adjustable - and adjustable towbar, the towbar should be as level as possible and the compressor and towing eye end in a level position.

Push the hand brake lever (1) completely downwards and connect breakaway cable (2) to the vehicle. Secure jockey wheel (3) or support leg in the highest possible position (see figure). The jockey wheel is prevented from turning.

HEIGHT ADJUSTMENT (with adjustable towbar)

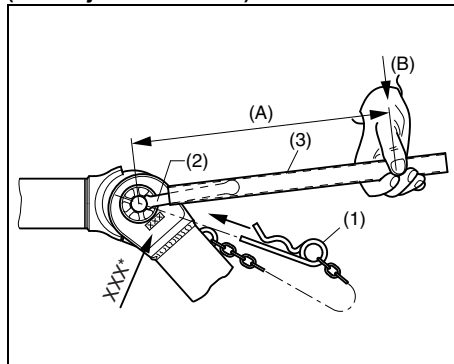

- Remove spring pin (1).
- Release locking nut (2) with support tools (Extension tube 3).
- Adjust required height of the towbar.
- Tighten locking nut (2) by hand first.
- Secondly tighten locking nut (2) with a tightening torque corresponding to table. With an extension tube (3) ("A" corresponding to table 1) and handforce ("B" corresponding to table 1) easy tightening is possible.
- Fix locking nut (2) with spring pin (1).



Attention:

- Height adjustment should be undertaken on levelled ground and in coupled condition.
- When readjusting, make sure that the front point of the towbar is horizontal to the coupling point.
- Before starting a trip, ensure that the adjustment shaft is secure, so that the stability and safety is guaranteed while driving. If necessary tighten the locking nut (2) corresponding to table.



Before towing the compressor, make sure that the joints of the towbar are secured with maximum strength without damaging the towbar. Be sure that there is no clearance between the teeth of the joints.

For specific instruction see below!

Type	M [Nm/lbf.ft.]	"A" [mm/in]	"B" [N/lbf]
ZV 2000	250 - 300 / 184.5 - 221.4	600 / 23.4	420 - 500 / 94.5 - 112.5
ZV 2500	350 - 400 / 258.3 - 295.2	600 / 23.4	580 - 660 / 130.5 - 148.5

INSTRUCTIONS BALL COUPLING (OPTION)

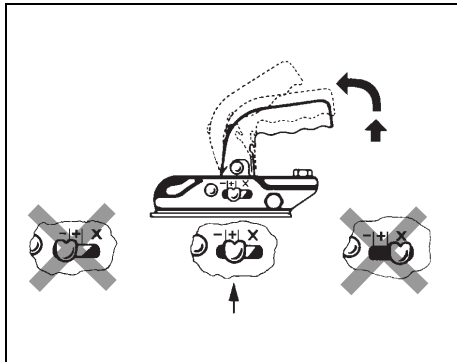

The handle of the ball coupling and the handbrake lever may never be used as a manoeuvring aid; internal components may get damaged!

The coupling (ball coupling) on the tow bar is type approved. The maximum load at the coupling may not be exceeded.

When coupling lower the jockey wheel to the ground. Reverse the car up to the compressor or, in the case of a small compressor, manoeuvre the compressor up to the car's trailer coupling.

Coupling:

Open coupling jaw by pulling the lever vigorously upwards in the direction of the arrow. Lower the opened coupling onto the ball of the vehicle coupling and the lever will automatically be lowered. Closing and locking are carried out automatically. Check the "+" (see figure) position!

Connect the breakaway cable and electrical plug (option) to the towing vehicle. Raise the jockey wheel up fully and secure by firmly clamping it. Release parking brake before setting off.

Visual check: the ball should no longer be visible in coupled condition.

Uncoupling:

Lower the jockey wheel. Disconnect breakaway cable and electrical plug. Pull the lever vigorously upwards in the direction of the arrow and hold. Wind down jockey wheel (option) and lift the compressor off the ball of the towing vehicle.

Secure the compressor by means of a wheel chock and/or by applying the parking brake.

LIFTING INSTRUCTIONS

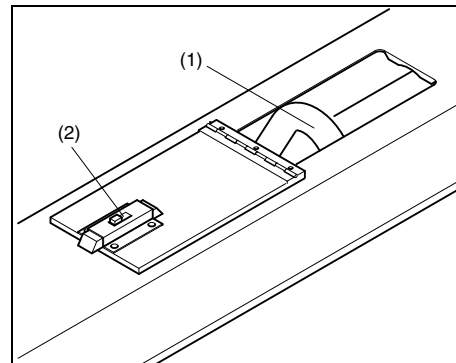

When lifting the compressor, the hoist has to be placed in such a way that the compressor, which must be placed level, will be lifted vertically. Keep lifting acceleration and retardation within safe limits.

Preferably use the lifting eye (1) herefore open the small door (2).



Lifting acceleration and retardation must be kept within safe limits (max. 2g).

Helicopter lifting is not allowed.

Lifting is not allowed when the unit is running.

STARTING/STOPPING

BEFORE STARTING

1. Before initial start-up, prepare battery for operation if not already done. See section **Battery care**.
2. With the compressor standing level, check the level of the engine oil. Add oil, if necessary, to the upper mark on dipstick. Consult the Engine Operation Manual for the type and viscosity grade of the engine oil.
3. Check the level of the compressor oil. See section **Compressor regulating system**. The pointer of oil level gauge (OLG) should register in the green range. Add oil if necessary. See section **Lubrication oils** for the oil to be used.



Before removing oil filler plug (FP), ensure that the pressure is released by opening an air outlet valve.

4. Check that the fuel tank contains sufficient fuel. Top up, if necessary. Consult the Engine Operation Manual for the type of fuel.
5. Drain any water and sediment from the fuel filter until clean fuel flows from the drain cock.
6. Press vacuator valves (VV) of the air filters to remove dust.
7. Check the air filter vacuum indicators (VI). If the yellow piston reaches the red marked service range, replace the filter element. Reset the indicator by pushing the reset button.
8. Open air outlet valve to allow air flow to the atmosphere.

CONTROL PANEL

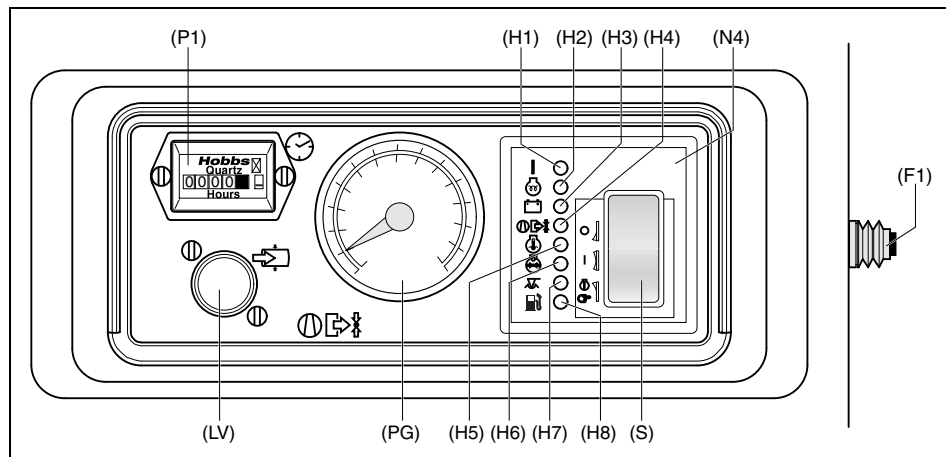

P1	Hourmeter
F1	Circuit Breaker Button
PG	Working pressure gauge
LV	Loading Valve
N4	Control Module
S	Start/Stop Button
H1	LED (green) Fuel ON
H2	LED (green) Preheat (option)
H3	LED (red) Charge Indication
H4	LED (red) Compressor Outlet Temperature
H5	LED (red) Engine Oil Temperature
H6	LED (red) Engine Oil Pressure
H7	LED (red) Low Coolant
H8	LED (red) Low Fuel



Never push the start button when the engine is running.

Make sure the fuel tank is filled up.

Before starting, first operate the circuit breaker button (F1) at the right side of the control panel (open right-hand service door first).

To start, the start/stop button (S) is switched to position "I", the green fuel ON lamp (H1), the red charge indication lamp (H3) and preheat lamp (H2) go on (preheat lamp only, if "cold start" option is installed). After preheating, the preheat lamp goes out. Push the start/stop button in position "I" (with the arrow). 20 sec. (60 sec. for XAHS 186 Dd) cranking, 1 min. rest (= a cycle). Max. 3 cycles are allowed. The starter motor will set the engine in motion. Lamps H1 and H3 will go out as soon as the engine has been started. After the start/stop button is released, it automatically springs back to position "I".

Run the engine a few minutes at no-load to warm up.

When the engine is running smoothly, press loading valve (LV) and release as soon as pressure starts to build up.

Shutting down is simply done by pushing the start button in the "0" position.

The control panel in addition indicates receiver pressure (PG) and accumulated operating hours (P1).

Fault situations and protective devices (Also refer to chapter Problem solving):

- The starter motor is protected against prolonged starting.
(max. cranking time: 20 sec. (60 sec. for XAHS 186 Dd)).
- A fault which occurs with the engine, either alternator voltage (too low), coolant temperature too high, oil pressure too low or fuel level too low will always and immediately cause the engine to cut out and one of the control lamps H3, H5, H6, H7 or H8 to light up.
- When the outlet temperature of the element becomes too high, a thermocontact will also switch off the unit immediately.
Control lamp H4 will light up.
- The control lamps will remain on until the unit has been reset (start button switched to position "0").

DURING OPERATION



When the engine is running, the air outlet valves (ball valves) must always be put in a fully opened or fully closed position.

Regularly carry out following checks:

1. That regulating valve (see section **Main Parts**, RV) is correctly adjusted, i.e. starts decreasing the engine speed when reaching the preset working pressure in the receiver.
2. Check the air filter vacuum indicators (see section **Main Parts**, VI). If the yellow piston reaches the red marked service range, replace the filter element. Reset the indicators by pushing the reset button.



The doors must be closed during operation and may be opened for short periods only.

Maintenance

USE OF SERVICE PAKS

Service Paks include all genuine parts needed for normal maintenance of both compressor and engine.

Service Paks minimize downtime and keep your maintenance budget low.

Order Service Paks at your local Atlas Copco dealer.

PREVENTIVE MAINTENANCE SCHEDULE FOR THE COMPRESSOR

The schedule contains a summary of the maintenance instructions. Read the respective section before taking maintenance measures.

When servicing, replace all disengaged packings, e.g. gaskets, O-rings, washers.

For engine maintenance refer to Engine Operation Manual.

The maintenance schedule has to be seen as a guideline for units operating in a dusty environment typical to compressor applications. Maintenance schedule can be adapted depending on application environment and quality of maintenance.

Maintenance schedule	Daily	50 hours after initial start-up	Every 500 hours	Every 1000 hours
Service Paks				
XAHS 146 Dd - XAHS 300 DD6 Deutz TCD			2912 4499 05	2912 4501 06
XATS 156 Dd - XATS 350 DD6 Deutz TCD XA(S) 186 Dd - XA(S) 375 DD6 Deutz TCD			2912 4499 05	2912 4502 06
XATS 156 Dd - XATS 350 DD6 Deutz BF4M XA(S) 186 Dd - XA(S) 375 DD6 Deutz BF4M			2912 4306 05	2912 4337 06
XAVS 166 Dd - XAVS 340 DD6 Deutz TCD XAHS 186 Dd - XAHS 375 DD6 Deutz TCD			2912 4500 05	2912 4503 06
Oil Separator Kit				2911 0075 00
Engine oil level	Check			
Compressor oil level	Check			
Coolant level (3)	Check			
Coolant (7)			Analysis	Analysis
Air filter vacuator valves	Empty			
Fuel filter water drain	Drain			

(to be continued on page 34)

Maintenance schedule <i>(continuation of page 33)</i>	Daily	50 hours after initial start-up	Every 500 hours	Every 1000 hours
Air intake vacuum indicators	Check			
Electrolyte level and terminals of battery		Check	Check	Check
Leaks in air-, oil- or fuel system		Check	Check	Check
Coolers (Oil, Coolant, Inter-)			Clean	Clean
Engine minimum and maximum speeds		Check	Check	Check
Safety valve				Test
Door hinges			Grease	Grease
Shutdown switches				Check
Pressure drop over separator element (2)			Measure	Replace (6)
Fan V-belts (3)			Adjust	Adjust
Fuel tank			Clean	Clean
Compressor oil				Change
Compressor oil filter				Replace
Air filter elements (1)				Replace
Safety cartridges (1) (option)				Replace
Engine oil (3) (4)			Change	Change
Engine oil filter (3)			Replace	Replace
Fuel filter (3) (5)			Replace	Replace
Fuel prefilter (3)			Replace	Replace
Engine inlet and outlet valves (3)				Adjust
PD/QD filter (option)				Replace

Notes



1. More frequently when operating in a dusty environment.
2. Replace the element when the pressure drop exceeds 0.8 bar (11.6 psi).
3. Every 1500 hours. Refer to the Deutz operation manual.
4. 500 hours is only valid when using PAROIL 15W40.
5. In case of poor fuel quality, replace fuel filter more frequently.
6. Clean retainer when replacing element.
7. The following part numbers can be ordered from Atlas Copco to check on inhibitors and freezing point:
 - 2913 0028 00 refractometer
 - 2913 0029 00 pH meter.



Keep the bolts of the housing, the lifting beam, tow bar and axles securely tightened. For torque values see section Technical specifications.

Maintenance schedule	Initially	Interval
Wheels		
Tyre pressure		Before each run
Check wheel bolts for firm seating	Before first run	
Check hub caps for firm seating		2,500km/annually
Check tyres for uneven wear		2,500km/annually
Check lateral play of bearings	After 500 km	2,500km/annually
Check brake lining wear		5,000km/annually
Towbar		
Check coupling head for wear, operation and fastening	Before first run	5,000km/annually
Check brake play	After first run	2,500km/annually
Check height adjustment facility	Before each run, during first 500 km	5,000km/annually
Check reversing lever for ease of motion	2,500 km	5,000km/annually
Check safety cable and bowden cable for damage		5,000km/annually
Check/ adjust brake system (if installed)	Before first run	2,500km/annually
Lubrication		
Coupling head and all its moving parts/shaft	Before first run	2,500km/annually
Overrun brake	Before first run	5,000km/annually
Reversing lever	Before first run	5,000km/annually
Overrun coupling	Before first run	5,000km/annually
Joints of height adjustable towbar		5,000km/annually
Bearings (conventional bearings only)		5,000km/annually

FUEL

For fuel specifications, please contact your Atlas Copco Customer Center.

LUBRICATION OILS

High-quality, mineral, hydraulic or synthesized hydrocarbon oil with rust and oxidation inhibitors and anti-foam and anti-wear properties is recommended. The viscosity grade should correspond to the ambient temperature and ISO 3448, as follows:

Type of lubricant	Compressor**	Engine*
between -25°C (-13°F) and +40°C (104°F)	PAROIL S	
between -10°C (14°F) and +40°C (104°F)	PAROIL M	PAROIL 15W40

PAROIL from Atlas Copco is the ONLY oil tested and approved for use in all engines built into Atlas Copco compressors and generators.

Extensive laboratory and field endurance tests on Atlas Copco equipment have proven PAROIL to match all lubrication demands in varied conditions. It meets stringent quality control specifications to ensure your equipment will run smoothly and reliably.

The quality lubricant additives in PAROIL allow for extended oil change intervals without any loss in performance or longevity.

PAROIL provides wear protection under extreme conditions. Powerful oxidation resistance, high chemical stability and rust-inhibiting additives help reduce corrosion, even within engines left idle for extended periods.

PAROIL contains high quality anti-oxidants to control deposits, sludge and contaminants that tend to build up under very high temperatures.

PAROIL's detergent additives keep sludge forming particles in a fine suspension instead of allowing them to clog your filter and accumulate in the valve/rocker cover area.

PAROIL releases excess heat efficiently, whilst maintaining excellent bore-polish protection to limit oil consumption.

PAROIL has an excellent Total Base Number (TBN) retention and more alkalinity to control acid formation.

PAROIL prevents Soot build-up

PAROIL is optimized for the latest low emission EURO -3 & -2, EPA TIER II & III engines running on low sulphur diesel for lower oil and fuel consumption.

PAROIL 5W40 is a Synthetic ultra high performance diesel engine oil with a high viscosity-index. Atlas Copco PAROIL 5W40 is designed to provide excellent lubrication from start-up in temperatures as low as -25°C (-13°F).

PAROIL 15W40 is a mineral based high performance diesel engine oil with a high viscosity-index. Atlas Copco PAROIL 15W40 is designed to provide a high level of performance and protection in 'standard' ambient conditions as from -15°C (5°F).



*
If you want to use another brand of oil, consult the Engine Operation Manual.



**
It is strongly recommended to use Atlas Copco branded lubrication oils for both compressor and engine. If you want to use another brand of oil, consult Atlas Copco.



Never mix synthetic with mineral oil.

Remark:

When changing from mineral to synthetic oil (or the other way around), you will need to do an extra rinse:

After doing the complete change procedure to synthetic oil, run the unit for a few minutes to allow good and complete circulation of the synthetic oil. Then drain the synthetic oil again and fill again with new synthetic oil. To set correct oil levels, proceed as in normal instruction.

Mineral compressor oil PAROIL M

	Liter	US gal	Order number
can	5	1.3	1615 5947 00
can	20	5.3	1615 5948 00
barrel	210	55.2	1615 5949 00

Synthetic compressor oil PAROIL S

	Liter	US gal	Order number
can	5	1.3	1615 5950 01
can	20	5.3	1615 5951 01
barrel	210	55.2	1615 5952 01
container	1000	265	1604 7422 00

Mineral engine oil PAROIL 15W40

	Liter	US gal	Order number
can	5	1.3	1615 5953 00
can	20	5.3	1615 5954 00
barrel	210	55.2	1615 5955 00

Synthetic engine oil PAROIL 5W40

	Liter	US gal	Order number
can	5	1.3	1604 6060 01
can	20	5.3	1604 6059 01

OIL LEVEL CHECK



Never mix oils of different brands or types.

Use only non-toxic oils where there is a risk of inhaling delivered air.

CHECK ENGINE OIL LEVEL

Consult also the Engine Operation Manual for the oil specifications, viscosity recommendations and oil change intervals.

For intervals, see **Preventive maintenance schedule for the compressor.**

Check engine oil level according to the instructions in the Engine Operation Manual and top up with oil if necessary.

CHECK COMPRESSOR OIL LEVEL

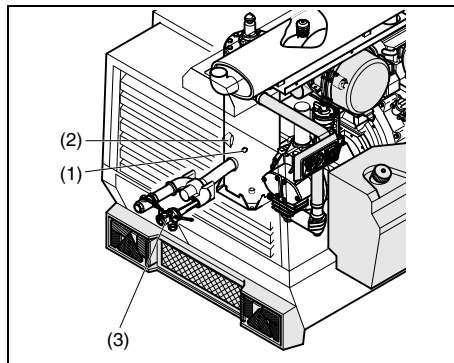

With the unit standing level, check the level of the compressor oil. The pointer of the oil level gauge (1) must register in the upper extremity of the green range. Add oil if necessary.



Before removing oil filler plug (2), ensure that the pressure is released by opening an air outlet valve.

OIL AND OIL FILTER CHANGE

ENGINE OIL AND OIL FILTER CHANGE

See section **Preventive maintenance schedule for the compressor**.

COMPRESSOR OIL AND OIL FILTER CHANGE

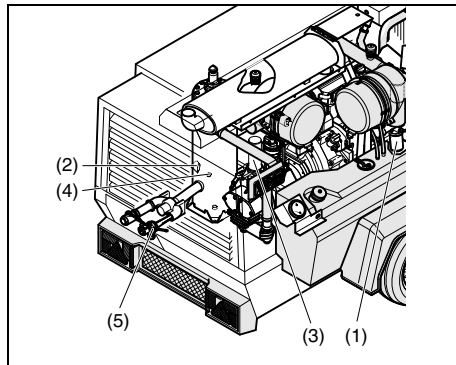

The quality and the temperature of the oil determine the oil change interval.

The prescribed interval is based on normal operating conditions and an oil temperature of up to 100 °C (212 °F) (see section **Preventive maintenance schedule for the compressor**).

When operating in high ambient temperatures, in very dusty or high humidity conditions, it is recommended to change the oil more frequently.



In this case, contact Atlas Copco.

1. Run the compressor until warm. Close the outlet valve(s) (1) and stop the compressor. Wait until the pressure is released through the automatic blow-down valve. Unscrew the oil filler plug (2) one turn. This uncovers a vent hole, which permits any pressure in the system to escape.
2. Drain the compressor oil by removing all relevant drain plugs. Drain plugs are located at the air receiver (DPar), compressor element (DPev, DPosv) and compressor oil cooler (DPoc). Catch the oil in a drain pan. Screw out the filler plug (2) to speed up draining. After draining, place and tighten the drain plugs.
3. Remove the oil filters (3), e.g. by means of a special tool. Catch the oil in a drain pan.
4. Clean the filter seat on the manifold, taking care that no dirt drops into the system. Oil the gasket of the new filter element. Screw it into place until the gasket contacts its seat, then tighten one half turn only.
5. Fill the air receiver until the pointer of the oil level gauge is in the upper part of the green area. Be sure that no dirt gets into the system. Reinstall and tighten the filler plug (2).
6. Start the compressor and let it run unloaded for a few minutes.
7. Stop the compressor, wait a few minutes and top up with oil until the pointer of the oil level gauge is in the upper part of the green area.



Never add more oil. Overfilling results in oil consumption.

COOLANT SPECIFICATIONS



Never remove the cooling system filler cap while coolant is hot.

The system may be under pressure. Remove the cap slowly and only when coolant is at ambient temperature. A sudden release of pressure from a heated cooling system can result in personal injury from the splash of hot coolant.



It is strongly recommended to use Atlas Copco branded coolant.

The use of the correct coolant is important for good heat transfer and protection of liquid-cooled engines. Coolants used in these engines must be mixtures of good quality water (distilled or de-ionised), special coolant additives and if necessary freeze protection. Coolant that is not to manufacturer's specification will result in mechanical damage of the engine.

The freezing point of the coolant must be lower than the freezing point that can occur in the area. The difference must be at least 5°C (9°F). If the coolant freezes, it may crack the cylinder block, radiator or coolant pump.

Consult the engine's operation manual and follow the manufacturer's directions.



Never mix different coolants and mix the coolant components outside the cooling system.

PARCOOL EG

PARCOOL EG is the only coolant that has been tested and approved by all engine manufacturers currently in use in Atlas Copco compressors and generators.

Atlas Copco's PARCOOL EG extended life coolant is the new range of organic coolants purpose designed to meet the needs of modern engines. PARCOOL EG can help prevent leaks caused by corrosion. PARCOOL EG is also fully compatible with all sealants and gasket types developed to join different materials used within an engine.

PARCOOL EG is a ready to use Ethylene Glycol based coolant, premixed in an optimum 50/50 dilution ratio, for antifreeze protection guaranteed to -40°C (-40°F).

PARCOOL EG

	Liter	US gal	Order number
can	5	1.3	1604 5308 00
can	20	5.3	1604 5307 01
barrel	210	55.2	1604 5306 00

To ensure protection against corrosion, cavitation and formation of deposits, the concentration of the additives in the coolant must be kept between certain limits, as stated by the manufacturer's guidelines. Topping up the coolant with water only, changes the concentration and is therefore not allowed.

Liquid-cooled engines are factory-filled with this type of coolant mixture.

PARCOOL EG Concentrate

	Liter	US gal	Order number
can	5	1.3	1604 8159 00

Because PARCOOL EG inhibits corrosion, deposit formation is minimized. This effectively eliminates the problem of restricted flow through the engine coolant ducts and the radiator, minimizing the risk for engine overheating and possible failure.

It reduces water pump seal wear and has excellent stability when subjected to sustained high operating temperatures.

PARCOOL EG is free of nitride and amines to protect your health and the environment. Longer service life reduces the amount of coolant produced and needing disposal to minimise environmental impact.

HANDLING PARCOOL EG

PARCOOL EG should be stored at ambient temperatures, while periods of exposure to temperatures above 35°C (95°F) should be minimized. PARCOOL EG can be stored for a minimum of 5 years in unopened containers without any effect on the product quality of performance.

PARCOOL EG is compatible with most other coolants based on ethylene glycol, but you only get the benefits of 5 years protection when its used on its own. Exclusive use of PARCOOL EG is recommended for optimum corrosion protection and sludge control.

For simple density-measuring of Ethylene Glycol and Propylene Glycol in general the standard available 'density' measuring devices are used to measure the concentration of EG. In case a device is used to measure EG, no PG can be measured afterwards as a result of the difference in the density. More specific measurements can be done by the use of a refractometer. This device can measure both EG and PG. A mix of both products will be show unreliable results!

Mixed EG coolants with identical glycol type can be measured by use of a refractometer as well as the 'density' system. The mixed coolants will be considered as one product.

The use of distilled water is recommended. If you have exceptionally soft water it would be acceptable, as well. Basically, the engine metals are going to corrode to some extent no matter what water you use, and hard water will encourage the resulting metal salts to precipitate.

PARCOOL EG comes as a pre-mixed coolant to safeguard the quality of the complete product.

It is recommended that topping up of the cooling system is always done with PARCOOL EG.

COOLANT CHECK



Never remove the cooling system filler cap while coolant is hot.

The system may be under pressure. Remove the cap slowly and only when coolant is at ambient temperature. A sudden release of pressure from a heated cooling system can result in personal injury from the splash of hot coolant.

In order to guarantee the lifetime and quality of the product, thus to optimise engine protection, regular coolant-condition-analysis is advisable.

The quality of the product can be determined by three parameters:

Visual check

- Verify the outlook of the coolant regarding colour and make sure that no loose particles are floating around.

pH measurement

- Check the pH value of the coolant using a pH-measuring device.
- The pH-meter can be ordered from Atlas Copco with part number 2913 0029 00.
- Typical value for EG = 8.6.
- If the pH-level is below 7 or above 9.5, the coolant should be replaced.

Glycol concentration measurement

- To optimise the unique engine protection features of the PARCOOL EG the concentration of the Glycol in the water should be always above 33 vol.%.
• Mixtures with more than 68 vol.% mix ratio in water are not recommended, as this will lead to high engine operating temperatures.
- A refractometer can be ordered from Atlas Copco with part number 2913 0028 00.



In case of a mix of different coolant products this type of measurement might provide incorrect values.

TOPPING UP/REPLACING COOLANT

- Verify if the engine cooling system is in a good condition (no leaks, clean,...).
- Check the condition of the coolant.
- If the condition of the coolant is outside the limits, the complete coolant should be replaced (see section **Replacing the coolant**).
- Always top-up with PARCOOL EG Concentrate / PARCOOL EG.
- Topping up the coolant with water only, changes the concentration of additives and is therefore not allowed.

TOPPING UP WITHOUT DRAINING FROM THE COOLING SYSTEM

The quantity of PARCOOL EG Concentrate to be topped up can be estimated with the following formula and/or graph:

Corrections concentrate in measured system towards 50% volume by using PARCOOL EG Concentrate

PN: 1604 8159 00

Example:

Total volume coolant = 14 Liter

Measured concentration = 33 Vol. %

$$50 - \frac{33}{33} = 17 * \frac{14}{50} = 4,8 \text{ Liter PARCOOL EG Concentrate}$$

Top-up volume PARCOOL EG Concentrate without drainage

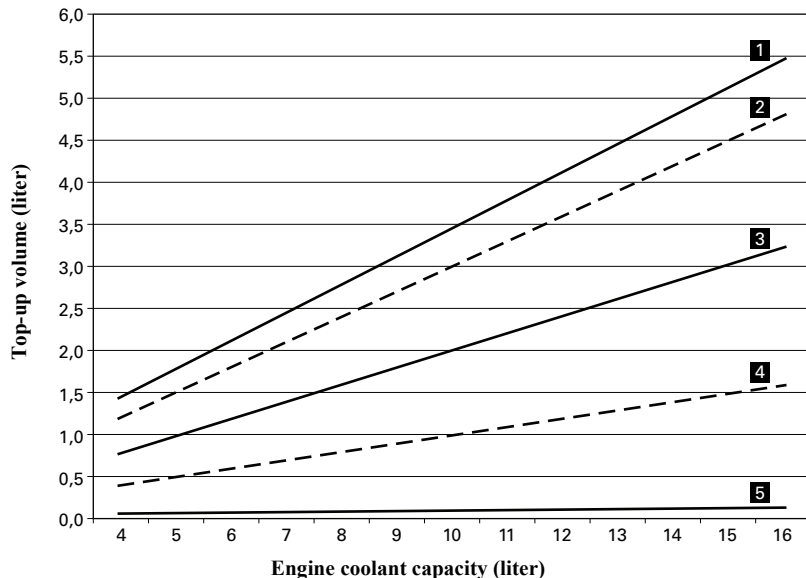

In case of expansion tank at low level, this quantity is to be filled without draining from the cooling system.

- 1 Refractometer indication -20° C (-4° F) (33%)
- 2 Refractometer indication -22° C (-7.6° F)
- 3 Refractometer indication -25° C (-13° F)
- 4 Refractometer indication -30° C (-22° F)
- 5 Refractometer indication -36° C (-32.8° F)

TOPPING UP AFTER LIMITED QUANTITY DRAINING FROM THE COOLING SYSTEM

The quantity of PARCOOL EG Concentrate to be topped up after draining a calculated volume from the cooling system, can be estimated with the following formula and/or graph:

Corrections concentrate in measured system towards 50% volume by using PARCOOL EG Concentrate

PN: 1604 8159 00

Example:

Total volume coolant = 80 Liter

Measured concentration = 33 Vol. %

50- 33 = 17 * 80 / 67 = 20 Liter PARCOOL EG Concentrate

100- 33 = 67

Top-up volume PARCOOL EG Concentrate with drainage

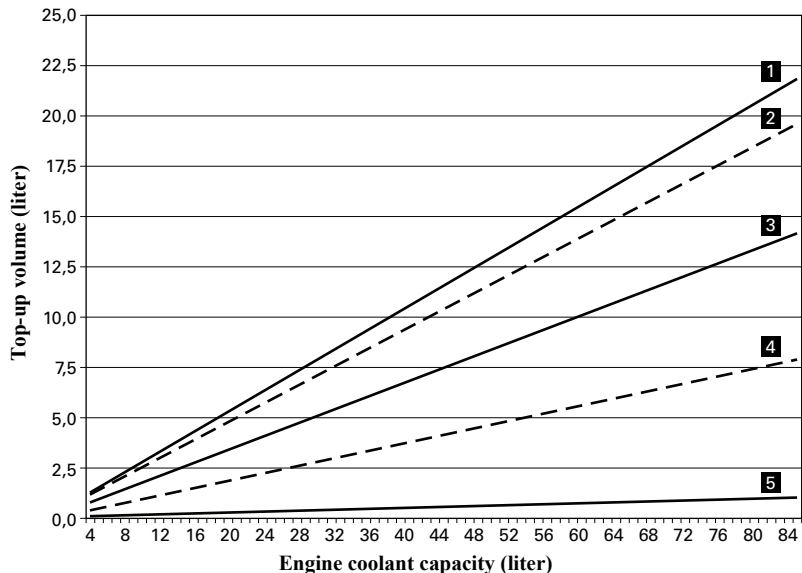

In case of expansion tank at normal level, this quantity is to be drained from the cooling system.

- 1 Refractometer indication -20° C (-4° F) (33%)
- 2 Refractometer indication -22° C (-7.6° F)
- 3 Refractometer indication -25° C (-13° F)
- 4 Refractometer indication -30° C (-22° F)
- 5 Refractometer indication -36° C (-32.8° F)

REPLACING THE COOLANT

Drain

- Completely drain the entire cooling system.
- Used coolant must be disposed or recycled in accordance with laws and local regulations.

Flush

- Flush twice with clean water. Used coolant must be disposed or recycled in accordance with laws and local regulations.
- From the Atlas Copco Instruction book, determine the amount of PARCOOL EG required and pour into the radiator top tank.
- It should be clearly understood that the risk for contamination is reduced in case of proper cleaning.
- In case a certain content of 'other' coolant remains in the system, the coolant with the lowest properties influences the quality of the 'mixed' coolant.

Fill

- To assure proper operation and the release of trapped air, run the engine until normal engine operation temperature is reached. Turn off the engine and allow to cool.
- Recheck coolant level and add coolant mixture if necessary.



In case of a mix of different coolant products this type of measurement might provide incorrect values.

CLEANING COOLERS

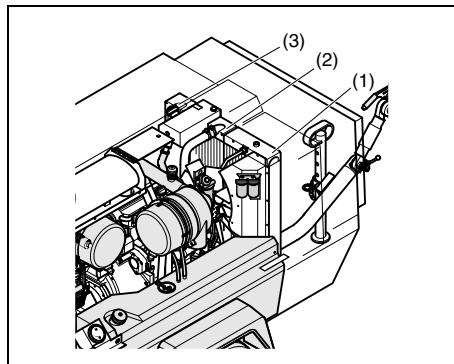

Keep the coolers clean to maintain the cooling efficiency.



Remove any dirt from the coolers with a fibre brush. Never use a wire brush or metal objects.

Then clean by air jet in reverse direction of normal flow.

Steam cleaning in combination with a cleansing agent may be applied.



To avoid damaging the coolers, angle between jet and coolers should be approx. 90°. (do not use jet at max. power)



Protect the electrical and controlling equipment, air filters, etc. against penetration of moisture.

Close the service door(s).



Never leave spilled liquids such as fuel, oil, water and cleansing agents in or around the compressor.



Caution: do not top off when the engine is hot.

BATTERY CARE



Before handling batteries, read the relevant safety precautions and act accordingly.

If the battery is still dry, it must be activated as described in section **Activating a dry-charged battery**.

The battery must be in operation within 2 months from being activated; if not, it needs to be recharged first.

ELECTROLYTE



Read the safety instructions carefully.

Electrolyte in batteries is a sulphuric acid solution in distilled water.

The solution must be made up before being introduced into the battery.

ACTIVATING A DRY-CHARGED BATTERY

- Take out the battery.
- Battery and electrolyte must be at equal temperature above 10°C (50°F).
- Remove cover and/or plug from each cell.
- Fill each cell with electrolyte until the level reaches 10 mm (0.4 in) to 15 mm (0.6 in) above the plates, or to the level marked on the battery.
- Rock the battery a few times so that possible air bubbles can escape; wait 10 minutes and check the level in each cell once more; if required, add electrolyte.
- Refit plugs and/or cover.
- Place the battery in the compressor.

RECHARGING A BATTERY

Before and after charging a battery, always check the electrolyte level in each cell; if required, top up with distilled water only. When charging batteries, each cell must be open, i.e. plugs and/or cover removed.



Use a commercial automatic battery charger according to its manufacturer's instructions.

Apply with preference the slow charging method and adjust the charge current according to the following rule of thumb:

battery capacity in Ah divided by 20 gives safe charging current in Amp.

BATTERY MAINTENANCE

- Keep the battery clean and dry.
- Keep the electrolyte level at 10 mm (0.4 in) to 15 mm (0.6 in) above the plates or at the indicated level; top up with distilled water only.
- Keep the terminals and clamps tight, clean, and lightly covered with petroleum jelly.

STORAGE

Run the compressor regularly, e.g. twice a week, until warm.

Load and unload the compressor a few times to operate the unloading and regulating components. Close the air outlet valves after stopping.



If the compressor is going to be stored without running from time to time, protective measures must be taken.

SERVICE PAKS

A Service Pak is a collection of parts to be used for a specific maintenance measure.

It guarantees that all necessary parts are replaced at the same time keeping down time to a minimum.

The order number of the Service Paks are listed in the Atlas Copco Parts List.

SERVICE KITS

A service kit is a collection of parts to fit a specific repair or rebuilding task.

It guarantees that all necessary parts are replaced at the same time which improves the uptime of the unit.

The order numbers of the Service Kits are listed in the Atlas Copco Parts List.



Contact Atlas Copco.

COMPRESSOR ELEMENT OVERHAUL

When a compressor element is due for overhaul, it is recommended to have it done by Atlas Copco. This guarantees the use of genuine parts and correct tools with care and precision.

LIABILITY

The manufacturer does not accept any liability for any damage arising from the use of non-original parts and for modifications, additions or conversions made without the manufacturer's approval in writing.

Adjustments and servicing procedures

ADJUSTMENT OF THE CONTINUOUS REGULATING SYSTEM

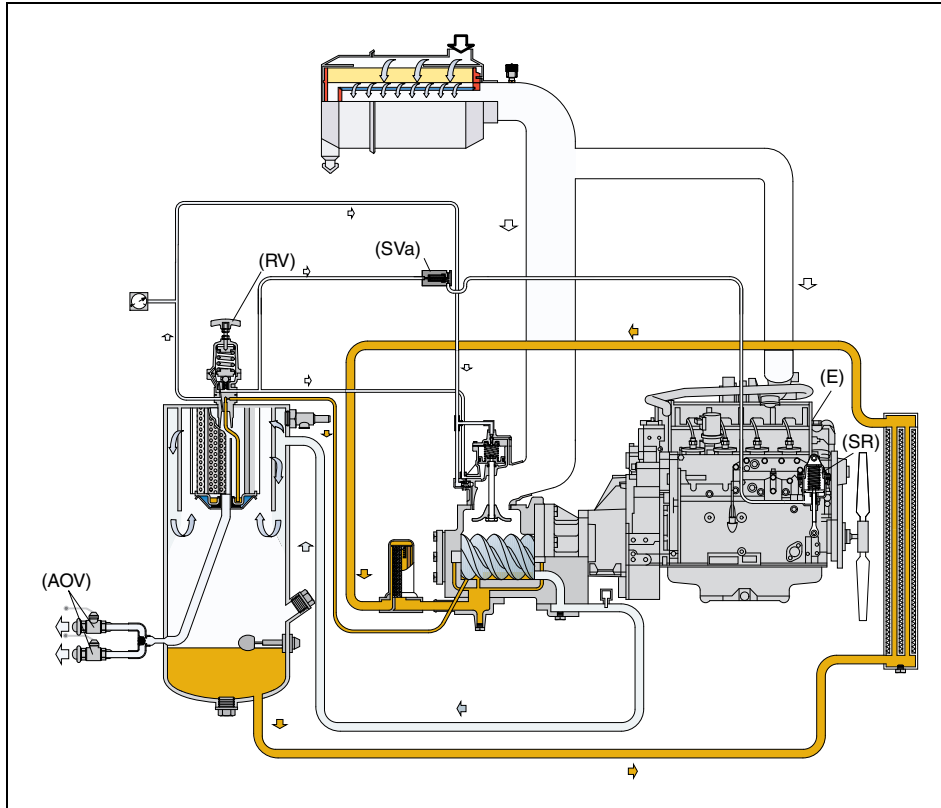

The working pressure is determined by the tension of the spring in the regulating valve (RV). This tension can be increased to raise the pressure and decreased to lower it by turning the adjusting wheel clockwise and anti-clockwise respectively.

		X	Y	Z1 – Z2
XAHS 146 Dd	bar(e)	13.5	12	13.2 – 13.6
	psi	196	174	191.5 – 197.5
XATS 156 Dd	bar(e)	11.8	10.3	11.7 – 12.2
	psi	171	149	167 – 173
XA(S) 186 Dd	bar(e)	8.3	7	8.1 – 8.5
	psi	120.5	101.5	117.5 – 123.5
XAVS 166 Dd	bar(e)	15.5	14	15.3 – 15.7
	psi	225	203	219 – 227
XAHS 186 Dd	bar(e)	13.5	12	13.3 – 13.7
	psi	196	174	191.5 – 197.5

To adjust the normal working pressure, proceed as follows:

1. Start and warm up the engine (see section **Starting/Stopping**).
2. With the outlet valves (AOV) closed, loosen the regulating valve's lock nut and adjust the regulating valve (RV) until a pressure of X bar(e) is reached (see table).
3. Check the minimum speed of the engine. Adjust minimum speed stop screw if necessary.
4. Open an outlet valve (AOV) just enough to let the engine (E) run at maximum speed. The working pressure must be Y bar(e); adjust if necessary with regulating valve (RV) (see table).
5. Check the engine maximum speed. Adjust the maximum speed by means of adjusting eccentric nut on top of speed regulator (SR).
6. Close the outlet valves (AOV), check that the pressure is between Z1 and Z2 bar(e) (see table). Lock the regulating valve (RV) by fixing the lock nut.

AIR FILTER ENGINE/COMPRESSOR

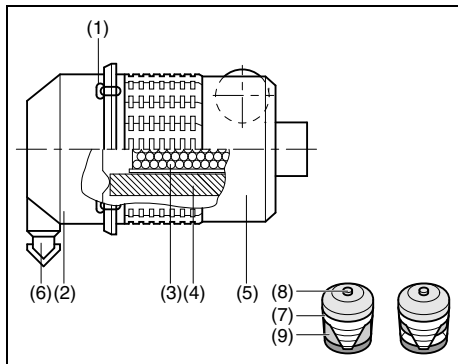

- | | |
|------------------------------|---------------------|
| 1. Snap clips | 6. Vacuator valve |
| 2. Dust trap cover | 7. Vacuum indicator |
| 3. Safety cartridge (option) | 8. Reset button |
| 4. Filter element | 9. Yellow indicator |
| 5. Filter housing | |

CLEANING THE DUST TRAP

Remove dust daily.

To remove dust from the dust trap pinch the vacuator valve (6) several times.

RECOMMENDATIONS



The Atlas Copco air filters are specially designed for the application. The use of non-genuine air filters may lead to severe damage of engine and/or compressor element.

Never run the compressor without air filter element.

New elements must also be inspected for tears or punctures before installation.

Discard the element (4) when damaged.

In heavy duty applications it is recommended to install a safety cartridge which can be ordered with part no.: 2914 9311 00

A dirty safety cartridge (3) is an indication of a malfunctioning air filter element. Replace the element and the safety cartridge in this case.

The safety cartridge cannot be cleaned.

REPLACING THE AIR FILTER ELEMENT

1. Release the snap clips (1) and remove the dust trap (2). Clean the trap.
2. Remove the element (4) and the safety cartridge.
3. Reassemble in reverse order of dismantling. Make sure the vacuator valve (6) points down.
4. Inspect and tighten all air intake connections.
5. Reset the vacuum indicator by pressing the reset button (5).

AIR RECEIVER

The air receiver (1) is tested according to official standards. Regularly have inspections carried out in conformity with local regulations.

SAFETY VALVE



All adjustments or repairs are to be done by an authorized representative of the valve supplier.

Following checks must be carried out on the safety valve (2):

- a check of the opening of the lifting gear, twice a year. This can be done by screwing the cap of the valve anti-clockwise.
- a check of the set pressure once a year according to the local regulations. This check cannot be done on the machine and must be carried out on a proper test bench.

FUEL SYSTEM

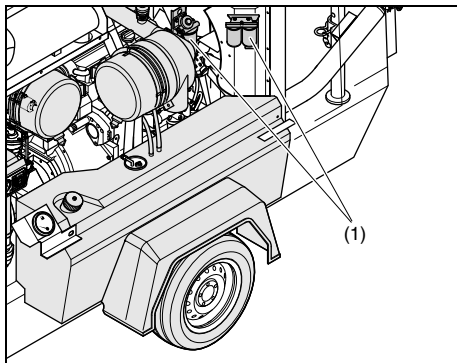

Replacing the filter element

1. Unscrew the filter element (1) from the adapter head.
2. Clean the adapter head sealing surface. Lightly oil the gasket of the new element and screw the latter onto the header until the gasket is properly seated, then tighten with both hands.
3. Check for fuel leaks once the engine has been restarted.

BRAKE (= OPTION) ADJUSTMENT



Before jacking up the compressor, connect it to a towing vehicle or attach a weight of minimum 50 kg (110 lb) to the towbar.

BRAKE SHOE ADJUSTMENT

Check the thickness of the brake lining. Remove both black plastic plugs (5), one on each wheel. When the brake lining has been worn to a thickness of 1 mm (0.039 in) or less, the brake shoes have to be replaced. After inspection and/or replacement re-insert both plugs.

Brake shoe adjustment re-establishes the brake lining-to-drum clearance and compensates for lining wear.

Lift and support the compressor. Make sure that all brakes are off (overrunbrake and hand brake lever). The brake cables must be free from tension. Lock the swivel cams of the wheel brake from the outside by means of a pin \varnothing 4 mm (4) through the hole as shown in the Figure.

Turn the adjusting bolt (1) clockwise with a wrench till the wheel locks up. Center the brake shoes by actuating the parking brake several times.

Turn the adjusting bolt anti-clockwise until the wheel is running free in direction of travel (approx. 1 full turn of the adjusting bolt).

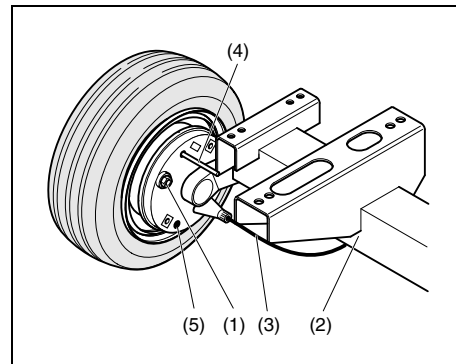

- | | |
|-------------------|---------------------------|
| 1. Adjusting bolt | 4. Pin \varnothing 4 mm |
| 2. Axle | 5. Plug |
| 3. Brake cable | |

Check the position of the equalizer (see section **Brake cable adjustment**, 6) with the parking brake actuated.

Perpendicular position of equalizer = identical clearance of wheel brakes.

Re-adjust the brake shoes, if necessary.

To test, slightly apply the parking brake and check identical brake torque on left and right side.

Remove locking pin (4). Remove clearance from brake cables.

Check all lock nuts (**Brake cable adjustment**, 2).

TEST PROCEDURE OF BRAKE CABLE ADJUSTMENT

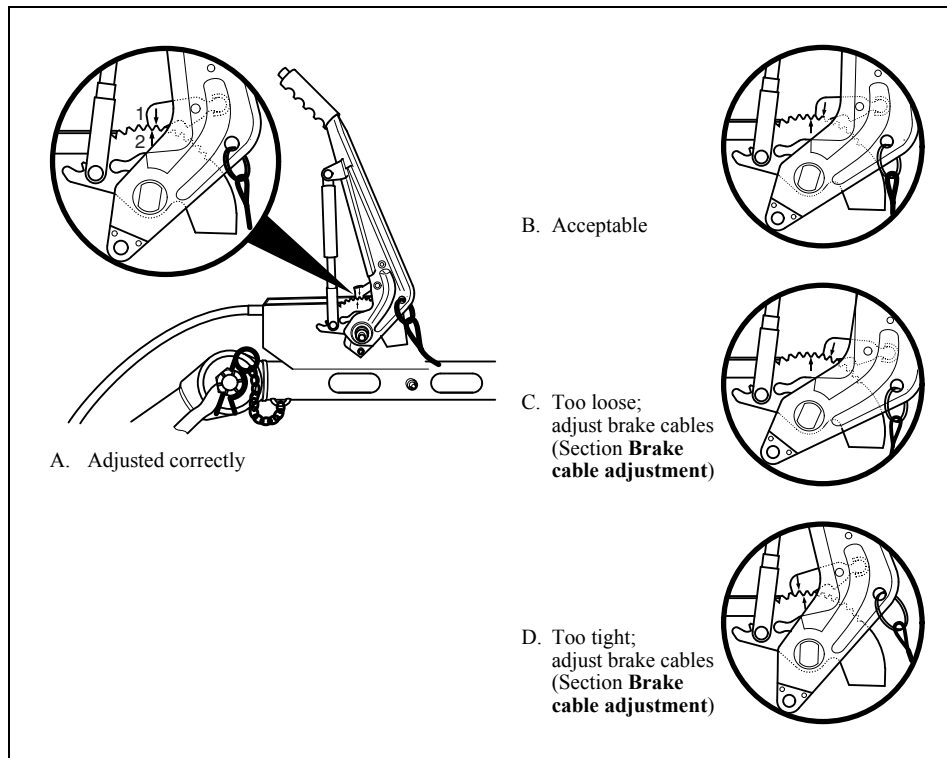

Correct and wrong position of markings

1. Check if the towing eye rod of the overrun brake mechanism is in the outmost position.
2. Check if the adjustable towbar (= option) is in the actual towing position.
3. Apply the hand brake lever.
4. Push the compressor a few centimeters backwards so that the brake lever is automatically pulled further up.
5. Check the position of the arrow marking "1" at the catch lock in combination with the arrow marking "2" at the toothed sector, according to A,B,C,D.

BRAKE CABLE ADJUSTMENT

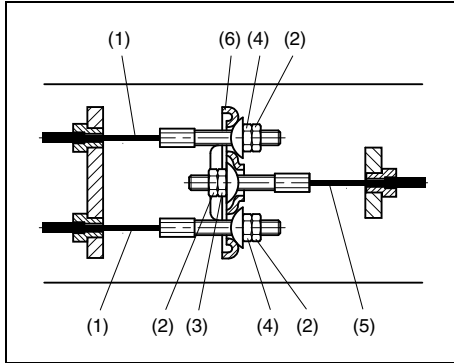

- | | |
|------------------|---------------------|
| 1. Brake cable | 4. Brake cable nut |
| 2. Lock nut | 5. Main brake cable |
| 3. Adjusting nut | 6. Equalizer |

1. With the towing eye pulled out in the outmost position and the hand brake lever in the downward position (see Figure), loosen the lock nuts (2). Turn adjusting nuts and brake cable nuts (4) clockwise until there is no slack in the brake mechanism.

The equalizer (6) must remain perpendicular to main brake cable (5).

2. Apply the hand brake lever several times and repeat the adjustment. Tighten the nuts with their lock nuts (2). Remove the jack and the blocks.
3. Road test the compressor and brake several times. Check brake shoe and brake cable adjustment and if necessary adjust.

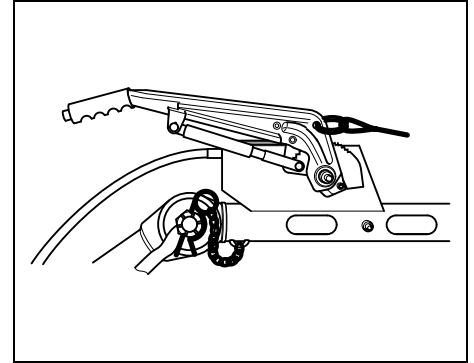

Hand brake lever downward - brake not operated

WHEELS

WHEEL CHECK

- Check wheel bolts for firm seating (initially)
- Check hub caps for firm seating (every 2,500 km or annually)
- Check tyres for uneven wear (every 2,500 km or annually)
- Check lateral play of wheel bearing. If necessary, readjust.

Compact bearings (every 2 years)

Conventional bearings (after 500 km, every 2,500 km or annually)

LUBRICATION

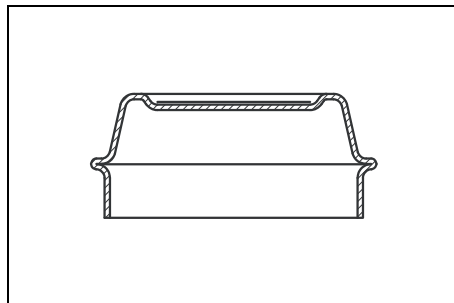

Tapered type hub cap

Taper roller bearings and deep groove ball bearing

Axles fitted with taper roller bearings are recognizable by a tapered type hub cap, see Figure.

Remove wheels and wheel hubs.

Mark dismantled wheel hubs and bearing races so that their identity is not mistaken during reassembly.

Clean wheel hubs thoroughly inside and outside. Remove old grease totally.

Clean taper roller bearings and seals (using diesel oil) and check for reuseability.

Work BPW special longlife grease ECO_Li 91 into the cavities between the taper roller and cage. Smear grease into the hub's outer bearing race.

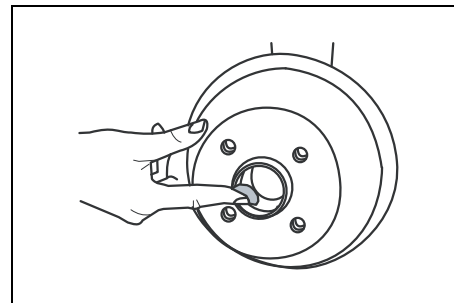

Greasing bearing race

Fill the hub caps to 3/4 full with grease.

Fit wheel hubs, adjust the bearing play and fit the hub caps.

WHEEL BOLTS CHECK

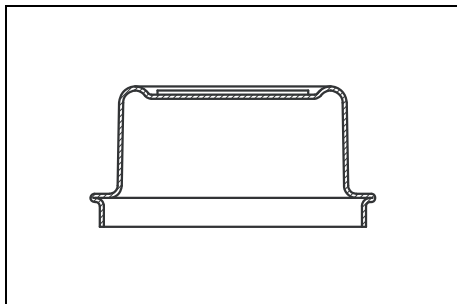

Cylindrical hub cap shape

Compact bearings

Compact bearings are recognizable by cylindrical hub cap shape, see Figure.

Compact bearings are maintenance-free due to permanent lubrication and are designed for high mileages.

Therefore, there is no grease change or regreasing necessary.

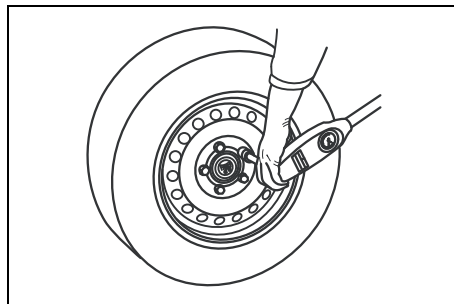

Wheel bolts tightening



After the first run, likewise after each wheel change.

Tighten wheel bolts crosswise using a torque wrench to the tightening torque in compliance with the table.

Tightening torques of wheel bolts

Spanner width (mm)	Thread	Tightening torque
17 (19)	M 12x1.5 80	100 Nm
19	M 14x1.5 110	120 Nm
24	M 18x1.5 270	280 Nm

WHEEL BEARING ADJUSTMENT

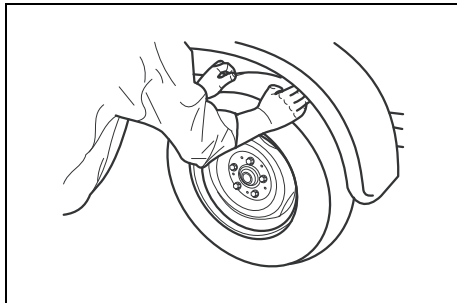

Bearing play

Jack up the compressor, release brakes.

Turn wheels manually and rock.

If any bearing play is perceivable, adjust the bearings.

Conventional taper roller bearings

Taper roller bearings are recognisable by the conical profile of the hub cap.

- Lever off hub cap. Remove split pin from axle nut and tighten so that rotation of the wheel is slightly braked.
- Turn back the axle nut to the next possible split pin hole, by a maximum of 30 degrees.
- Insert split pin and bend ends slightly outwards.
- Check wheel rotation, fit hub cap.

Important:

The grease in the hub cap and bearing must not be contaminated with dirt during this job!

Compact bearings

Compact bearings are recognizable by their cylindrical hub cap shape.



If noticeable bearing play is felt, the compact bearings should be replaced.

TOWBAR AND OVERRUN BRAKE

TOWBAR AND OVERRUN BRAKE CHECK

Check coupling head



Initially, then every 5,000 kilometres or annually.

Check coupling head for wear and correct operation.

Check the wear indicator (use within the "+" range only).

Check the coupling head fastenings (see arrows, Figure) at regular intervals for firm seating.

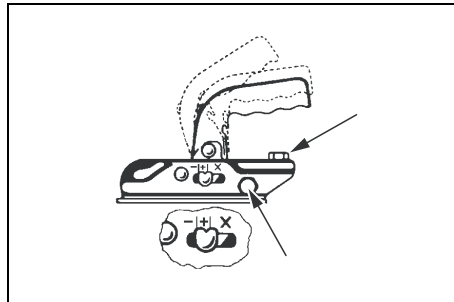

Check the coupling head fastenings

Check height adjustment facility



Initially, before every journey, after 500 kilometres, then every 5,000 kilometres or annually.

After every adjustment the clamping nuts must be screwed up tight and secured with the spring elements.

Tightening torque:

M 24 = 250 - 350 Nm

M 32 = 350 - 400 Nm

Check tight fit of the clamping nuts and correct positioning of the adjustment facility.

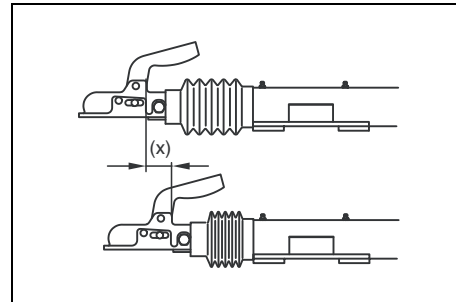

Brake play check

Brake play check



After the first run, then every 2,000 - 3,000 kilometres.

The check is carried out visually on the stroke (x) of the overrun coupling.

As soon as this is more than 50 mm when the brakes are applied, adjust the wheel brakes.

Check towbar, handbrake lever, spring actuator, reversing lever, linkage and all movable parts for ease of movement.

LUBRICATION

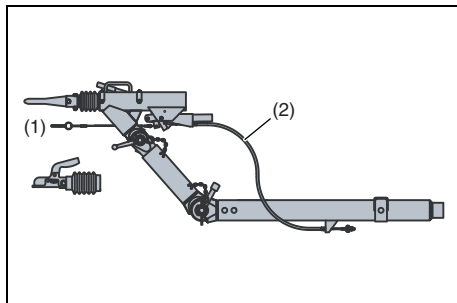

Towbar

 **Initially, then every 5,000 kilometres or annually.**

Check safety cable (1) for damage; every 5,000 kilometres or annually.

Check Bowden cable (2) on height-adjustable connection devices for damage; every 5,000 kilometres or annually.

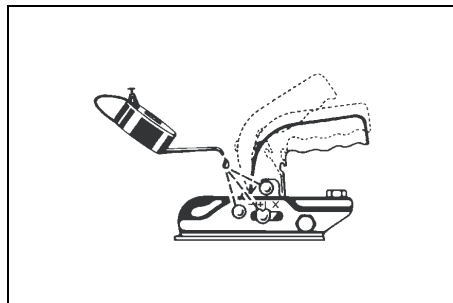

Lubrication coupling head

Lubricate the coupling head

 **At regular intervals.**

Oil ball coupling at regular intervals at the specified locations and moving parts.

Grease the contact surface of the ball of the towing vehicle.

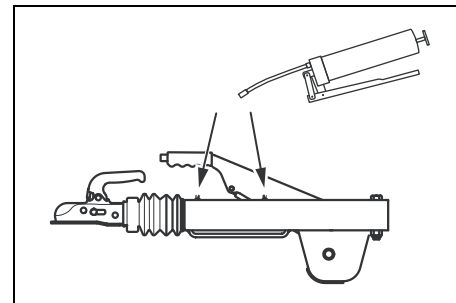

Greasing towbar

Towbar bushes on the housing of the overrun coupling

 **Initially, after 2,000 - 3,000 kilometres, every 5,000 kilometres.**

Apply general purpose grease via the grease nipples until fresh grease can be seen emerging from the bushes.

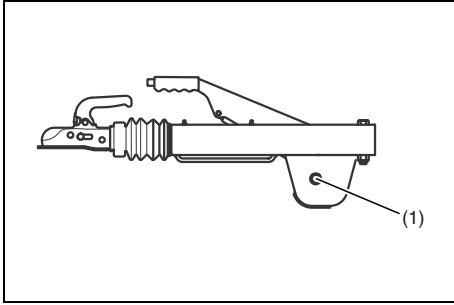

Reversing lever

Reversing lever

 **Initially, after 2,000 - 3,000 kilometres, every 5,000 kilometres.**

Check reversing lever (1) for ease of motion.

If fitted, apply general purpose grease via the grease nipple until fresh grease can be seen emerging from the bush.

If grease nipples are not fitted, then apply oil to the reversing lever bush.

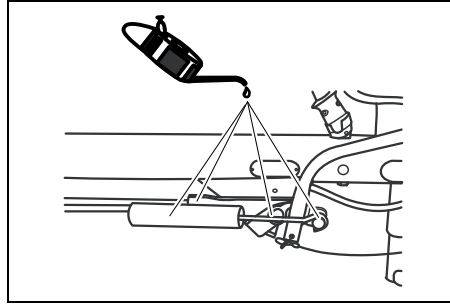

Lubrication points

Lubricate all moving parts and pivot pins at the overrun coupling

 **Initially, after 2,000 - 3,000 kilometres, every 5,000 kilometres.**

All moving parts of drawbar, handbrake lever, spring actuator, reversing lever, linkages etc. to be oiled or greased as required.

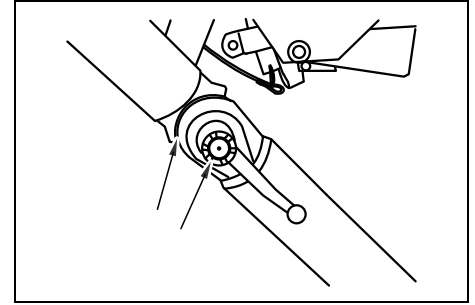

Height adjusting device

Grease sliding locations on the height-adjusting device

 **For the first time after 2,000 - 3,000 kilometres travelled, then every 5,000 kilometres.**

Oil threaded parts and grease toothed parts.

Problem solving

It is assumed that the engine is in good condition and that there is adequate fuel flow to the filter and injection equipment.

Make sure that the wires are not damaged and that they are clamped tight to their terminals.



An electrical fault must be traced by an electrician.



For position of dip switches refer to section Electrical system.

Problem	Possible faults	Corrective actions
1. Starter motor does not crank engine after switching start button (S) to "ⓘ".	a. Low battery output.	a. Check electrolyte level and charge battery. If no cells are shorted and battery is discharged, trace cause and correct.
2. Starter motor cranks engine when switching start button (S) to "ⓘ", but engine does not fire.	a. Low battery output.	a. See corrective action 1.
3. Engine fires, but engine stops when releasing start button (S).	a. Alternator drive belt broken or slipping. b. Alternator/regulator defective.	a. Check and correct if necessary. b. Have assembly repaired.
4. Hourmeter (P1) does not count running time.	a. Hourmeter (P1) defective.	a. Replace.
5. Engine is running, but shuts down immediately after start button (S) has been released.	a. Start button (S) released too soon. b. Insufficient engine oil pressure. c. Fuel tank contains insufficient fuel.	a. Release button after engine oil pressure has built up above the minimum allowed level. b. Stop at once, consult the engine instruction manual. c. Fill fuel tank.
6. Compressor is loaded automatically to full capacity after starting.	a. Loading valve stuck in loading position. b. Air intake throttle valve stuck in opened position. c. Air leaks in regulating system.	a. Remove and dismantle loading valve. Correct if necessary. b. Check and, if necessary consult Atlas Copco. c. Check hoses and their fittings. Stop leaks; replace leaking hoses.

Problem	Possible faults	Corrective actions
7. Unit does not load after pressing the loading button.	a. Regulating valve defective.	a. Check and if necessary consult Atlas Copco.
8. Engine does not speed up immediately after compressor loading valve button has been pressed and compressor does not deliver air.	a. Regulating valve defective. b. Air intake throttle valve stuck in closed position.	a. Check and, if necessary consult Atlas Copco. b. Check and, if necessary consult Atlas Copco.
9. Excessive compressor oil consumption. Oil mist being discharged from air outlet valves.	a. Compressor oil level too high.	a. Check oil level. Release pressure and drain oil to correct level.
10. Compressor capacity or pressure below normal.	a. Air consumption exceeds capacity of compressor. b. Choked air filter elements. c. Unloading valve not completely open.	a. Check equipment connected. b. Remove and inspect elements. c. Check and, if necessary consult Atlas Copco.
11. Compressor does not unload and engine keeps running at max. speed when closing the air outlet valves, safety valve blows.	a. Regulating valve incorrectly set or defective. b. Air leaks in regulating system. c. Unloading valve stuck.	a. Check and, if necessary consult Atlas Copco. b. Check hoses and their fittings. Stop leaks and, if necessary consult Atlas Copco. c. Check and, if necessary consult Atlas Copco.
12. Working pressure rises during operation and causes safety valve to blow.	a. Regulating valve incorrectly set or defective. b. Air leaks in regulating system. c. Unloading valve stuck. d. Safety valve defective.	a. Check and, if necessary consult Atlas Copco. b. Check hoses and their fittings. Stop leaks and, if necessary consult Atlas Copco. c. Check and, if necessary consult Atlas Copco. d. Check safety valve; consult Atlas Copco.
13. After working some time, the unit stops through a shutdown switch.	a. Fuel tank contains insufficient fuel. b. Air in fuel system, or insufficient fuel supply. c. Engine oil pressure too low. d. Engine temperature too high. e. Compressor temperature too high. f. Low coolant level.	a. Fill fuel tank. b. Check filters and hoses for leaks, dirt and bends. c. Refer to the engine instruction manual. d. See corrective actions 15. e. See corrective actions 16. f. Top up cooling system.

Problem	Possible faults	Corrective actions
14. Air and oil mist expelled from air filters immediately after stopping.	<ul style="list-style-type: none"> a. Unloader valve jammed. b. Wrong oil type (without foam-retarding additives). 	<ul style="list-style-type: none"> a. Check and, if necessary consult Atlas Copco. b. Consult Atlas Copco.
15. Engine overheating.	<ul style="list-style-type: none"> a. Insufficient engine cooling. b. Engine oil cooler clogged externally. 	<ul style="list-style-type: none"> a. Relocate compressor. b. Clean engine oil cooler. Refer to section Cleaning coolers.
16. Compressor overheating.	<ul style="list-style-type: none"> a. Insufficient compressor cooling. b. Oil cooler clogged externally. c. Oil level too low. 	<ul style="list-style-type: none"> a. Locate compressor away from walls; when banked with other compressors, leave space between them. b. Clean oil cooler. Refer to section Cleaning coolers. c. Check oil level. Top up with recommended oil.
17. After working for some time, the unit stops for no apparent reason.	<ul style="list-style-type: none"> a. Air in fuel system, or insufficient fuel supply. 	<ul style="list-style-type: none"> a. Check filters and hoses for leaks, dirt and bends.

Alternator precautions

1. Never reverse the polarity of the battery or the alternator.
2. Never break any alternator or battery connections while the engine is running.
3. When recharging the battery, disconnect it from the alternator. Before using booster cables to start the engine, be sure of the polarity and connect the batteries correctly.
4. Never operate the engine without the main or voltage sensing cables connected in the circuit.

Available options

Vessel type:	EURO
	ASME
Towbar:	Adjustable with brakes (A)
	Fixed with brakes (A)
	Fixed without brakes
Without towbar:	Support (without undercarriage)
Towing eyes:	Atlas Copco
	DIN
	Ball
	Italian
	GB
	NATO
	AC (France)
Towbar support:	Support leg
	Jockey wheel
Road signalisation:	Full (B)
Safety:	Wheel chocks
	Safety cartridge
Refinery equipment:	Spark arrestor
	Inlet shut down valve

Air quality equipment:	Aftercooler + water separator
	Aftercooler + water separator + fine filter PD
	Aftercooler + water separator + fine filter PD + QD
	Aftercooler + water separator + fine filter PD + reheater (C)
	Aftercooler + water separator + fine filter PD + QD + reheater (C)
	Aftercooler + water separator + reheater
	Lubricator on 7 bar units
Safety:	Wheel chocks
	Safety cartridge
Refinery equipment:	Spark arrestor
	Inlet shut down valve
Cold start:	-20 °C (-4 °F)
Customer colour:	Single
	Double
	Triple

- A. These units meet your local safety regulations and are available with overrun and parking brakes.
- B. Reflectors and lights for safety on the road.
- C. Quality air through the aftercooler, reheater and fine filters.

Technical specifications

TORQUE VALUES

FOR GENERAL APPLICATIONS

The following tables list the recommended torques applied for general applications at assembly of the compressor.

For hexagon screws and nuts with strength grade 8.8

Thread size	Torque value (Nm / lbf.ft)
M6	9 (6.64)
M8	23 (16.97)
M10	46 (34.69)
M12	80 (59.04)
M14	125 (92.25)
M16	205 (151.29)

For hexagon screws and nuts with strength grade 12.9

Thread size	Torque value (Nm / lbf.ft)
M6	15 (11.07)
M8	39 (28.78)
M10	78 (57.56)
M12	135 (99.63)
M14	210 (154.98)
M16	345 (254.61)

FOR IMPORTANT ASSEMBLIES

Assemblies	Torque value (Nm / lbf.ft)
Wheel nuts	270 (200) +/- 15
Bolts, axle/beams	205 (151.29) +/- 20
Bolts, towbar/axle	80 (59.04) +/- 10
Bolts, towbar/bottom	205 (151.29) +/- 20
Bolts, towing eye/towbar	80 (59.04) +/- 10
Bolts, lifting eye/flywheel housing	80 (59.04) +/- 10
Bolts, engine/drive housing (M12)	80 (59.04) +/- 10
Bolts, engine/drive housing (M14)	125 (92.25) +/- 10
Bolts, compressor element/drive housing	80 (59.04) +/- 5
Safety switches	35 (25.83) +/- 5
Joints adjustable towbar (M24)	275 (202.95) +/- 25
Joints adjustable towbar (M32)	375 (276.75) +/- 25



Secure the drain cock and tank cap of the fuel tank handtight.

SETTINGS OF SHUTDOWN SWITCHES AND SAFETY VALVES

Designation		XAHS 146 Dd	XATS 156 Dd	XA(S) 186 Dd	XAVS 166 Dd	XAHS 186 Dd	XATS 156 Dd	XA(S) 186 Dd
		XAHS 300 DD6	XATS 350 DD6	XA(S) 375 DD6	XAVS 340 DD6	XAHS 375 DD6	XATS 350 DD6	XA(S) 375 DD6
		COM3	COM3	COM3	COM3	COM3	COM2	COM2
Engine oil pressure	bar(e)	2	2	2	2	2	-	-
	psi	29	29	29	29	29	-	-
Engine oil temperature	°C	113	113	113	113	113	-	-
	°F	235	235	235	235	235	-	-
Compressor temperature	°C	120	120	120	120	120	-	-
	°F	248	248	248	248	248	-	-
Safety valve opening pressure								
- EC type	bar(e)	15	13.5	10	17	17	13.5	10
- ASME type	psi	218	200	150	250	250	200	150

COMPRESSOR/ENGINE/GENERATOR SPECIFICATIONS

REFERENCE CONDITIONS

Designation		XAHS 146 Dd XAHS 300 DD6	XATS 156 Dd XATS 350 DD6	XA(S) 186 Dd XA(S) 375 DD6	XAVS 166 Dd XAVS 340 DD6	XAHS 186 Dd XAHS 375 DD6	XATS 156 Dd XATS 350 DD6	XA(S) 186 Dd XA(S) 375 DD6
		COM3	COM3	COM3	COM3	COM3	COM2	COM2
Absolute inlet pressure	bar(e)	1	1	1	1	1	1	1
	psi	14.5	14.5	14.5	14.5	14.5	14.5	14.5
Relative air humidity	%	0	0	0	0	0	0	0
Air inlet temperature	°C	20	20	20	20	20	20	20
	°F	68	68	68	68	68	68	68
Nominal effective working pressure	bar(e)	12	10.5	7	14	12	10.3	7
	psi	174	152	102	203	174	149	102

The inlet conditions are specified at the air inlet grating outside the canopy.

LIMITATIONS

Designation			XAHS 146 Dd	XATS 156 Dd	XA(S) 186 Dd	XAVS 166 Dd	XAHS 186 Dd	XATS 156 Dd	XA(S) 186 Dd
			XAHS 300 DD6	XATS 350 DD6	XA(S) 375 DD6	XAVS 340 DD6	XAHS 375 DD6	XATS 350 DD6	XA(S) 375 DD6
			COM3	COM3	COM3	COM3	COM3	COM2	COM2
Minimum effective receiver pressure		bar(e)	4	4	4	4	4	4	4
		psi	58	58	58	58	58	58	58
Maximum effective receiver pressure, compressor unloaded		bar(e)	13.5	11.8	8.5	15.5	13.5	11.8	8.5
		psi	196	171	123	225	196	171	123
Maximum ambient temperature at sealevel	no aftercooler	°C	50	50	50	45	45	50	50
		°F	122	122	122	113	113	122	122
	with aftercooler	°C	49	47	47	40	40	-	-
		°F	114	114	114	104	104	-	-
Minimum starting temperature	no aftercooler	°C	-10	-10	-10	-10	-10	-10	-10
		°F	14	14	14	14	14	14	14
	with aftercooler	°C	-20	-20	-20	-20	-20	-20	-20
		°F	-4	-4	-4	-4	-4	-4	-4

PERFORMANCE DATA

At reference conditions, if applicable, and at normal shaft speed, unless otherwise stated.

Designation		XAHS 146 Dd	XATS 156 Dd	XA(S) 186 Dd	XAVS 166 Dd	XAHS 186 Dd	XATS 156 Dd	XA(S) 186 Dd	
		XAHS 300 DD6	XATS 350 DD6	XA(S) 375 DD6	XAVS 340 DD6	XAHS 375 DD6	XATS 350 DD6	XA(S) 375 DD6	
		COM3	COM3	COM3	COM3	COM3	COM2	COM2	
Engine shaft speed, normal and maximum	r/min	2300	2300	2300	2200	2200	2300	2300	
Engine shaft speed, compressor unloaded	r/min	1700	1700	1700	1700	1700	1700	1700	
Free air delivery ¹⁾	standard	l/s	151	161	185	158	173	166	185
		cfm	320	341	392	335	367	352	392
	with aftercooler	l/s	147	157	181	154	169	-	-
		cfm	311	333	384	326	358	-	-

¹⁾ Free Air Delivery (volume flow rate) is measured according to ISO 1217 ed.3 1996 annex D

Tolerance:

- +/- 5% 25 l/s (53 cfm) < FAD < 250 l/s (530 cfm)
- +/- 4% 250 l/s (530 cfm) < FAD

The international standard ISO 1217 corresponds to following national standards:

- British BSI 1571 part 1
- German DIN 1945 Part 1
- Swedish SS-ISO 1217
- American ANSI PTC9

Fuel consumption

Designation		XAHS 146 Dd	XATS 156 Dd	XA(S) 186 Dd	XAVS 166 Dd	XAHS 186 Dd	XATS 156 Dd	XA(S) 186 Dd	
		XAHS 300 DD6	XATS 350 DD6	XA(S) 375 DD6	XAVS 340 DD6	XAHS 375 DD6	XATS 350 DD6	XA(S) 375 DD6	
		COM3	COM3	COM3	COM3	COM3	COM2	COM2	
at 100% FAD	kg/h	18.1	18	17.4	21.2	21	18.3	17.4	
	lb/h	39.9	39.7	38.4	46.7	46.3	40.34	38.36	
at unload	kg/h	-	-	-	-	-	9.6	8.5	
	lb/h	-	-	-	-	-	21.17	18.74	
Specific fuel consumption									
at 100% FAD	standard	g/m ³	33.1	30.6	26.1	35.8	33.5	30.3	26
		lb/10 ³ cu.ft	2.07	1.91	1.63	2.24	2.09	1.88	1.62

Designation		XAHS 146 Dd	XATS 156 Dd	XA(S) 186 Dd	XAVS 166 Dd	XAHS 186 Dd	XATS 156 Dd	XA(S) 186 Dd	
		XAHS 300 DD6	XATS 350 DD6	XA(S) 375 DD6	XAVS 340 DD6	XAHS 375 DD6	XATS 350 DD6	XA(S) 375 DD6	
		COM3	COM3	COM3	COM3	COM3	COM2	COM2	
Typical oil content of compressed air	mg/m ³	< 5	< 5	< 5	< 5	< 5	< 5	< 5	
	oz/10 ³ cft	< 0.005	< 0.005	< 0.005	< 0.005	< 0.005	< 0.005	< 0.005	
Engine oil consumption (maximum)	g/h	18.2	17.8	17.4	20.8	20.9	14	14	
	oz/h	0.64	0.63	0.61	0.73	0.74	0.49	0.49	
Compressed air temperature at outlet valves	standard	°C	90	90	90	95	95	90	90
		°F	194	194	194	203	203	194	194
	with aftercooler	°C	ambient + 9	ambient + 9	ambient + 9	ambient + 9	ambient + 9	-	-
		°F	ambient + 16	ambient + 16	ambient + 16	ambient + 16	ambient + 16	-	-
Sound pressure level (LP), measured according to ISO 2151 under free field conditions at 7 m distance	dB(A)	71	71	71	71	71	72	71	
Sound power level (Lw) complies with 2000/14/EC	dB(A)	99	99	99	99	99	100	99	

DESIGN DATA

Compressor

Designation	
Number of compression stages	1

Engine

Designation		XAHS 146 Dd XAHS 300 DD6	XATS 156 Dd XATS 350 DD6	XA(S) 186 Dd XA(S) 375 DD6	XAVS 166 Dd XAVS 340 DD6	XAHS 186 Dd XAHS 375 DD6	XATS 156 Dd XATS 350 DD6	XA(S) 186 Dd XA(S) 375 DD6
		COM3	COM3	COM3	COM3	COM3	COM2	COM2
Make		Deutz	Deutz	Deutz	Deutz	Deutz	Deutz	Deutz
Type		TCD2012LO4	TCD2012LO4	TCD2012LO4	TCD2013LO4	TCD2013LO4	BF4M2012C	BF4M2012C
Coolant		Liquid	Liquid	Liquid	Liquid	Liquid	Liquid	Liquid
Number of cylinders		4	4	4	4	4	4	4
Bore	mm	101	101	101	108	108	101	101
	in	3.98	3.98	3.98	4.25	4.25	3.98	3.98
Stroke	mm	126	126	126	130	130	126	126
	in	4.96	4.96	4.96	5.12	5.12	4.96	4.96
Swept volume	l	4.038	4.038	4.038	4.764	4.764	4.038	4.038
	cu.in	246.4	246.4	246.4	251.2	251.2	246.4	246.4
Output according to SAE J1995 at normal shaft speed	kW	83	83	83	104	104	90	90
	BHP	113	113	113	141	141	122	122
- Load factor	%	65	65	65	65	65	70	70
Capacity of oil sump:								
- Initial fill	l	9	9	9	12	12	8.5	8.5
	US gal	2.2	2.2	2.2	2.9	2.9	2.0	2.0
- Refill (max.) ¹⁾	l	8.5	8.5	8.5	11.5	11.5	8	8
	US gal	2.0	2.0	2.0	2.8	2.8	1.9	1.9
Capacity of cooling system	l	14	14	14	16	16	14	14
	US gal	3.4	3.4	3.4	3.9	3.9	3.4	3.4

¹⁾ With filter change.

Unit

Designation		XAHS 146 Dd - XAHS 300 DD6 XATS 156 Dd - XATS 350 DD6 XA(S) 186 Dd - XA(S) 375 DD6 XAVS 166 Dd - XAVS 340 DD6 XAHS 186 Dd - XAHS 375 DD6 XATS 156 Dd - XATS 350 DD6 XA(S) 186 Dd - XA(S) 375 DD6
Capacity of compressor oil system	l	24
	US gal	5.9
Net capacity of air receiver	l	42
	US gal	10.3
Capacity of fuel tank	l	175
	US gal	43
Air volume at inlet grating (approx.) ¹⁾	m ³ /s	3.9
	cfm	8300

¹⁾ Air required for engine and compressor cooling, for combustion and for compression.

Unit dimensions

with brakes		towbar	
		fixed	adjustable
Length	mm	3941	4356
	in	155.2	171.5
Width	mm	1716	1716
	in	67.6	67.6
Height	mm	1661	1661
	in	65.4	65.4
Weight (ready-to-operate)	kg	1800	1825
	lb	3970	4025

Data plate

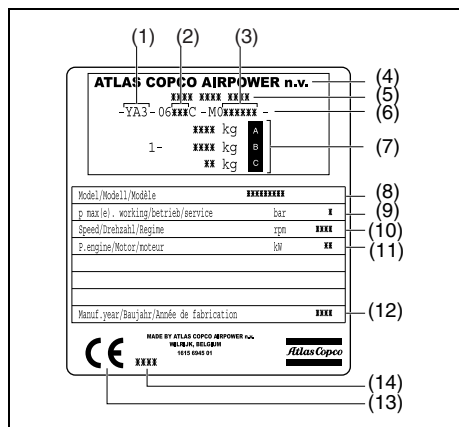

- 1 Company code
- 2 Product code
- 3 Unit serial number
- 4 Name of the manufacturer
- 5 EEC or national type approval number
- 6 Vehicle identification number
- 7 **A** Maximum permitted laden weight of the vehicle
- B** Maximum permitted road weight of the vehicle
- C** Maximum permitted laden weight of the towing eye
- 8 Model
- 9 Working pressure
- 10 Speed
- 11 Engine power
- 12 Manufacturing year
- 13 CE mark in accordance with Machine Directive 89/392 EC
- 14 Register number or number of notified body

Disposal

GENERAL

When developing products and services, Atlas Copco tries to understand, address, and minimize the negative environmental effects that the products and services may have, when being manufactured, distributed, and used, as well as at their disposal.

Recycling and disposal policy are part of the development of all Atlas Copco products. Atlas Copco company standards determine strict requirements.

Selecting materials the substantial recyclability, the disassembly possibilities and the separability of materials and assemblies are considered as well as the environmental perils and dangers to health during the recycling and disposal of the unavoidable rates of not recyclable materials.

Your Atlas Copco compressor consists for the most part of metallic materials, that can be remelted in steelworks and smelting works and that is therefore almost infinite recyclable. The plastic used is labelled; sorting and fractioning of the materials for recycling in the future is foreseen.



This concept can only succeed with your help. Support us by disposing professionally. By assuring a correct disposal of the product you help to prevent possible negative consequences for environment and health, that can occur with an inappropriate waste handling.

Recycling and re-usage of material helps to preserve natural resources.

DISPOSAL OF MATERIALS

Dispose contaminated substances and material separately, according to local applicable environmental legislations.

Before dismantling a machine at the end of its operating lifetime drain all fluids and dispose of according the applicable local disposal regulations.

Remove the batteries. Do not throw batteries into the fire (explosion risk) or into the residual waste. Separate the machine into metal, electronics, wiring, hoses, insulation and plastic parts.

Dispose all components according to the applicable disposal regulations.

Remove spilled fluid mechanically; pick up the rest with absorbing agent (for example sand, sawdust) and dispose it according the applicable local disposal regulations. Do not drain into the sewage system or surface water.

Maintenance Log

Compressor Customer

Serial number

Service hours	Maintenance action	Date	By initials



Notes

