

# FLOOR SANDER MODEL HTF-2

From Serial Number  
00579 (220/240 Volt) & 00579 (110/120 Volt)



## NORTH AMERICAN SAFETY INSTRUCTIONS



**WARNING:** *This floor sanding machine must be grounded.*

This floor-sanding machine shall be grounded while in use to protect the operator from electric shock. The machine is provided with a three-conductor cord and a moulded three-contact grounding type attachment plug to fit the proper grounding type receptacle. The Green (or Green and Yellow) conductor in the cord is the grounding wire. Never connect this wire to other than the grounding pin of the attachment plug.

This floor-sanding machine is provided with an attachment plug as shown in sketch A. It is intended for use on a nominal 120 volt circuit. If a properly grounded receptacle as shown in sketch A is not available, an adaptor as shown in sketch 'C' should be installed as shown in sketch B if the outlet box that houses the receptacle is grounded. Be sure to fasten the grounding tab with a metal faceplate screw.



**WARNING:** *Risk of explosion.*

Floor sanding can result in an explosive mixture of fine dust and air. Use floor-sanding machine only in a well-ventilated area free from any flame or match.



**WARNING:** *Of potential injury.*

Moving Parts - to reduce the risk of injury, unplug the machine before replacing abrasive sheets or carrying out any form of adjustment or servicing.

## USE AND APPLICATION

This machine is intended for commercial use connected with the laying and maintaining of wooden floors and decks.

These types of surfaces may be found both in commercial and household environments.

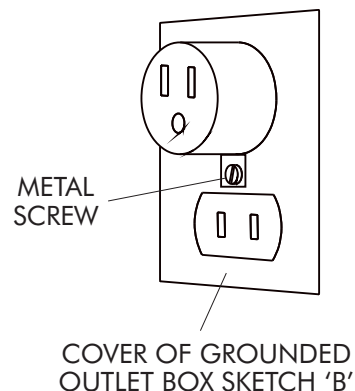
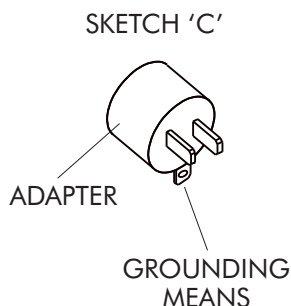
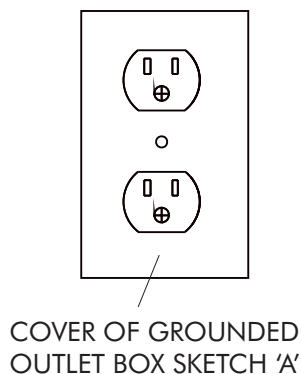
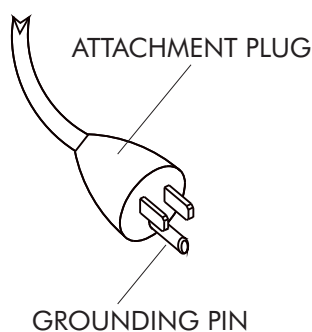

## CONTENTS

<b>WARNING</b>	i
<b>MAINS CABLE WIRING - PLUG</b>	i
<b>SPARE PARTS</b>	i
<b>SPECIFICATION</b>	1
<b>SAFETY</b>	1
<b>ASSEMBLY &amp; TRANSPORT</b>	2
<b>INSTALLING ABRASIVE</b>	2
<b>PREPARATION</b>	2,3
<b>OPERATION</b>	3
<b>FLOOR SANDING TECHNIQUE</b>	
Drum Floor Sander	4
Disc Floor Sander	4
Orbital Floor Sander	4
Hand Sanding	4
<b>FLOOR TYPES</b>	
Sanding Plank & Strip Floors	4
Veneered, Laminated & Thinner Floors	4
Parquet & Block Floors	5
Sanding Between Coats of Finish	5

## ABRASIVE PAPER GUIDE

<b>Hiretech</b> Abrasive Pad & Strips	6
<b>Hiretech</b> Coated Abrasives	6

## FLOOR SANDING TECHNIQUE 5

## SERVICE AND ROUTINE MAINTENANCE

General	7
Visual Inspection	7
Dust Control	7
Lubrication	7
Care of Motor	7,8
Setting the Wheels	8
Electrical Testing	8,9

## FAULT FINDING 9

## HTF-2 PARTS DRAWING 10,11

## HTF-2 PARTS LIST 12,13

## FLOOR SANDER ABRASIVES 13

## HTF-2 CIRCUIT DIAGRAM 14

## DECLARATION OF CONFORMITY 15

## SERVICE & REPAIR 16

## WARNING

For safe operation of this machine, read and understand all instructions. Look for the 'warning/caution' symbol.



*This symbol means that if you do not follow the instructions injury can occur to the operator and damage to the machine and floor may result.*

## MAINS CABLE WIRING - PLUG

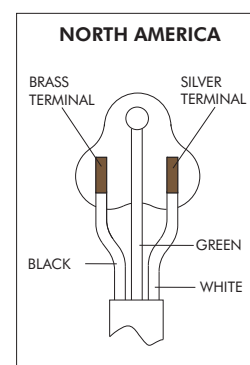
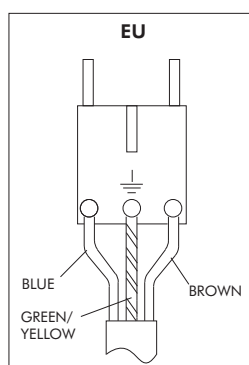
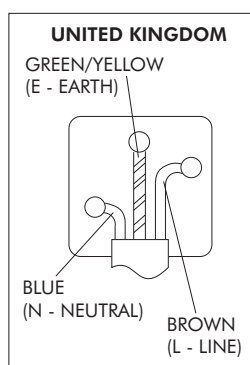

## SPARE PARTS

Use Hiretech genuine spare parts only for service and repair. Use of non-approved parts will void the product warranty. See the back cover of this manual for the terms and conditions of the Hiretech Limited Warranty.

**Hiretech® reserves the right to make changes or improvements to its products without prior notice.**

## SPECIFICATION

The HTF-2 Floor Sander will sand wood floors, including fine parquet, pre-finished and laminate wood flooring systems, cork and composition floors to a fine finish. Ideal for sanding between coats of floor varnish and lacquers were a very high quality, score free finish is required. The finally balanced orbital action will not leave swirl marks in the floor surface which may be highlighted when varnished. Designed for sanding floors that are level and in generally good condition were the existing varnish has worn and requires re-finishing. Completely self contained with a powerful dust pickup the HTF-2 is a high performance floor sander suitable for professional and home owner use.

<b>Power Supply:</b>	110/120 V 50/60 Hz 220/240 V 50/60 Hz
<b>Off Load Current:</b>	110/120 V 8A 220/250 V 5A
<b>Average Load Current:</b>	110/120 V 15A 220/250 V 8A
<b>Noise:</b>	95 dBa at 1 metre (3' 3")
<b>Switch:</b>	Bias Off, double pole.
<b>Motor:</b>	Continuous heavy duty AC/DC self cooling 4 brush.
<b>Motor RPM:</b>	10,000
<b>Sanding Pad RPM:</b>	3,000
<b>Sanding Pad:</b>	400mm (15¾") x 115mm (4½") MDF back with hook and loop face.
<b>Drive:</b>	Non-slip toothed timing belt and toughened steel pinion and drive gear.
<b>Moving Parts:</b>	Sealed for life ball bearings.
<b>Dust Pickup:</b>	Seated oversize vacuum fan, disposable paper dust or cloth bag.
<b>Vibration:</b>	8.89 m/s <sup>2</sup> r.m.s.
<b>Weight:</b>	43kg (94.8lbs)
<b>Abrasive:</b>	400mm (15¾") x 115mm (4½") random fibre abrasive pad 280 grit and backing pad.  400mm (15¾") x 115mm (4½") anti-clog adhesive backed sheet 40 to 180 grit.

## SAFETY

1. For safety it is recommended that a residual current circuit breaker (ground fault interrupter) is used with this machine.
2. Check the operating voltage is correct and that the machine is switched OFF (O) before connecting to the power supply.
3. Never attempt to lock the switch in the ON (I) position with tape or by any other means.
4. Always disconnect from the power supply when changing the abrasive, servicing the floor sander, replacing the dust bag or leaving the machine unattended.
5. Always replace the dust bag when the dust in the bag reaches the 'MAX' line or when the machine is left unattended.
6. Never dispose of or empty the contents of the dust bag into a fire or incinerator.
7. Never reuse the paper dust bag or use a non standard bag.
8. Always wear a dust mask when using the floor sander, handling the dust bag or cleaning the machine after use.
9. Wear ear protection when using the floor sander.
10. Ensure adequate ventilation of the work area to avoid the formation of a combustible mixture of flying dust and air.
11. Never smoke when using or servicing the floor sander or when handling the dust bag. Make sure that all possible sources of ignition are removed from the work area.
12. Never expose the machine to rain or damp. Always store in a dry place.
13. Stop the floor sander immediately if damage to the machine or abrasive is suspected.
14. Never allow the power cable to come into contact with the sanding pad when the floor sander is in operation. If the power cable becomes damaged and the inner conductors are exposed switch the power OFF (O) and remove the plug before attempting to move the machine. The cable must be replaced by an authorized agent or qualified electrician using genuine Hiretech® spare parts only.
15. Keep hands, feet and loose clothing away from all moving parts of the machine.
16. Punch down or remove all nails, screws, tacks and other fixings from the floor before sanding to prevent contact with the sanding pad.
17. Keep children and pets clear at all times.
18. If the machine should fail to operate refer to the fault finding guide on page 9.



Read the following Safety and Operational notes before using your HTF-2 Floor Sander.

## ASSEMBLY & TRANSPORT

1. The HTF-2 breaks down into two component parts, the main body and handle assembly for easy handling and transport. To assemble loosen the Handle Clamp Handle and fit the handle assembly to the Handle Yoke which should be locked in the upright position. Tighten the Handle Clamp firmly.
2. Pull the Dust Bag Frame down to its operating position. Connect the Handle Cable to the Body Twist Lock at the rear left hand side of the floor sander body. Align the plug with the pins, push in and twist clockwise to lock.
3. Fit a Hiretech disposable paper dust bag following the instructions printed on the bag.
4. Tip the floor sander back so that it rests on the Dust Bag Frame to fit the selected abrasive. Remove the power cable from the handle assembly. Check that the cable is in good condition and the strain relief and plug are secure. The floor sander is now ready to connect to the power supply and start sanding.
5. To dismantle the floor sander reverse the procedure 1 to 4 above.
6. Always carry the floor sander by the front hand grip and the handle yoke which must be locked in the upright position with the handle detached. The dust bag frame should be stowed in the up position.

### Main Components



**WARNING** - Never carry the floor sander by the handle assembly and body or with the handle assembly attached. Failure to observe this rule may result in personal injury and/or damage to the floor sander.

7. Transport the sander with the sanding block and abrasive pad in place this will help maintain the dust brushes in good condition. Always ensure that the floor sander is secure and cannot move when being transported in a vehicle. The floor sander is heavy. Take care when lifting and carrying the machine.

## INSTALLING ABRASIVE

1. Ensure the power cable is disconnected from the power supply.
2. Lock the handle in the upright position and tip the floor sander backwards so that it rests on the dust bag frame. If a sanding block is already fitted the abrasive may be fitted with the sanding block left in place or it may be removed if required.

To remove the sanding block take hold of each end of the block and pull it off its mounting posts. Take care to pull the block off evenly and avoid trapping your fingers between the block and the body of the floor sander.

3. Refer to the Abrasive Guide on page 6 for the correct abrasive to use.
4. **Abrasive Pad** - fit an abrasive pad to the sanding block. Carefully line the pad up with the face of the sanding block and push down. The pad is both a fine abrasive and a backing pad for the coated abrasive sheets. It is important that the pad is maintained in good condition and not used beyond its useful working life.



**CAUTION** - Do not use any other type of abrasive pad or backing material as this may damage the floor and/or floor sander.

5. **Abrasive Sheets** - peel off the backing to exposure the adhesive back and carefully fix the abrasive to the face of the abrasive pad making sure it is in line. When changing abrasive sheets peel off carefully so as not to destroy the face of the abrasive pad.
6. With the abrasive fixed to the sanding block re-fit the block (if removed) to the floor sander.
7. Stand the floor sander up, it is now ready to use.
8. Periodically check that the abrasive pad is still in line with the sanding block. If the machine is tipped back when in operation the abrasive pad may become misaligned.

## PREPARATION

1. Where possible remove all furniture from the room. The HTF-2 Floor Sander features an efficient dust pick-up, however, some dust will escape. Protect all vulnerable furnishings with dust sheets, masking films and tape.
2. Remove all tacks, staples and other unwanted fixings from the floor. Failure to do so will result in damage to the sanding pad and abrasive sheet or pad.
3. Punch all nails below the surface of the floor using a suitable nail punch and hammer. Any screws used to fix boards should be counter sunk below the surface. During sanding, any nails or screws that become exposed must be punched or counter sunk further.
4. Firmly fix all loose boards or blocks.
5. Remove heavy wax, grease and dirt deposits by hand.
6. Sweep and vacuum the floor thoroughly to remove dirt and discarded fixings.
7. Ensure good ventilation by opening windows.

## OPERATION

1. Move the floor sander to the location of your work.
2. Make sure the switch is in the OFF (O) position then connect the main cable to a suitable power supply ideally located behind or to one side of the machine and work area.
3. Wear a dust mask and ear defenders.
4. Hold the handle with both hands and depress foot pedal with your right foot. This will release the handle.
5. Switch ON by pushing the ON/OFF switch down using the thumbs of one hand to ON (I) position and hold in place. Start moving immediately. To switch OFF (O), release the pressure on the switch and it will automatically return to the OFF position.



*CAUTION - the HTF-2 Floor Sander is a powerful machine always ensure you have a firm grip before switching on.*

6. Follow the instructions carefully for sanding and re-finishing a floor (see page 4 & 5). Walk slowly forward and back, working progressively across the floor. Do not dwell in one place. The floor sander will glide easily across the surface of the floor.

7. When the dust in the dust bag reaches the 'MAX' line stop sanding. Switch OFF, disconnect the power cable from the power supply and remove the paper dust bag. Turn the top of the paper dust bag over to stop the escape of dust and dispose of into a suitable container. Fit a new paper dust bag. Reconnect to the power supply and continue sanding. Never reuse the paper dust bag or attempt to empty it.
6. Change the abrasive when the quality of the sanding is reduced or the abrasive becomes clogged.
- 7.. When taking a break from work switch OFF (O) and disconnect the power cable from the power supply, remove and dispose of the paper dust bag.
9. On completion disconnect the power cable from the power supply. Remove and dispose of the paper dust bag. Lock the handle in the upright position and stow the power cable. Lock the dust bag frame in its up position. Leave the old abrasive pad in-place to protect the dust brushes. Carry out maintenance as recommended in Maintenance and Servicing.



*DANGER - never leave the floor sander unattended with dust in the dust bag. Always remove the dust bag and dispose of into a suitable container.*



*CAUTION - to prevent damage to the floor surface, work piece or machine follow these rules.*

- (a) Always ensure that the floor sander is moving when in operation and the sanding pad is in contact with the floor.
- (b) Never lift the back or front of the machine when sanding.
- (c) Never apply pressure to try and increase the rate of sanding. Damage to the floor will occur.
- (d) Never bounce or drop the floor sander on to the floor, always lower the machine gently.
- (e) Never dwell in one place, move steadily at all times.
- (f) Never allow the power cable to come into contact with the sanding pad.



## FLOOR SANDING TECHNIQUE

**HT8-1.2 Floor Sander (Drum)** - a powerful floor sander designed for the rapid leveling and sanding of all types of wood flooring excluding thin laminated or veneered floors. Load the sander with abrasive making sure that it is skin tight around the drum. Loose sheets will tear. Place the sander on the right hand wall (unless you are making an angled cut on uneven floors) with about two thirds of the floor in front of you. Start the sander with the drum off the floor then walk forward at an even pace and ease the drum on to the floor. As you near the end of the pass, gradually raise the drum off the floor. Practice this technique before turning on the sander.

Cover the same path you made on the forward cut by pulling the machine backwards and easing the drum to the floor as you begin the backward pass until you reach the original starting point, then ease the drum off the floor.

When two thirds of the floor is sanded, turn the floor sander around and sand the remaining third in the same way. Overlap the one third area by 0.6 to 0.9 meters (2 to 3 feet ) with the two thirds area to blend the two areas together.



**WARNING** - never bounce the sanding drum or dwell in one place as this will sand dips and hollows in the floor.

**HT7-2 Disc Floor Sander (Edger)** - a powerful disc floor sander designed for sanding along the edges of a floor without damaging the baseboards or moldings. Also suitable for smaller areas where the HT8-1.2 Floor Sander will not reach like stair treads and closets. Load the abrasive disc making sure the retaining bolt is tight. Start the edger with the disc off the floor then lower the disc to the floor as you move the sander. Work progressively moving the sander in a sweeping motion from side to side.

**HTF-2 Floor Sander (Orbital)** - an orbital action floor sander designed for re-finishing, sanding between coats of varnish and re-surfacing floors in good condition. Load the abrasive sheet, pad or strip. Start the sander, move immediately and sand in the direction of the grain using the same technique as the drum floor sander. For difficult to reach areas use a heavy duty hand held orbital sander or sand by hand.

**Hand Sanding** - to sand difficult to reach areas scrape and sand the floor by hand. Use a scraper to remove old finishes, always scraping in the direction of the grain, and then sand by hand using the same grit abrasive as you finished with when machine sanding. See Floor Sanding Technique diagrams on page 5.

## FLOOR TYPES

### SOLID WOOD PLANK & STRIP FLOORS

**Old floors in good condition** - when the floor is in good condition - no uneven edges, cupping or crowning of planks and strips - and you want to re-surface the floor, sanding back to new wood, start sanding in the direction of the planks or strips - with the wood grain. Start with a medium grit abrasive. Complete the first cut with the HT8-1.2 Floor Sander then sand up to the baseboards and door thresholds with the HT7-2 Disc Floor Sander, using a medium grit abrasive, blending the edges in with the main floor area. Sweep the floor. Using a medium/fine grit abrasive, sand the main floor area with the drum sander and then complete the floor with the edger using a fine grit abrasive. Sweep the floor. Finish sanding the main floor area with the drum floor sander using a fine grit abrasive. If the floor is in particularly good condition (level with no deep scratches or blemishes) you may re-surface the floor using the HTF-2 Floor Sander, however, as the sanding action of this machine is less aggressive than the HT8-1.2 Floor Sander the job will take more time.

**Uneven floors** - when the floor is uneven sand diagonally at 45° across the room in both directions using the HT8-1.2 Floor Sander with a coarse grit abrasive. Only make one cut on both diagonals, this will achieve a basic level. Now complete the floor as for a level strip or plank floor. Use the same grit abrasive as was used on the 45° cut for the first cut parallel to the planks or strips.

**Floors with an existing finish** - when re-finishing a floor remove as little of the existing surface as possible. If the old finish is worn and the floor is generally in good condition use the HTF-2 Floor Sander with **Hiretech** abrasive pads and sheets which have been especially designed for re-finishing floors. These will maintain the integrity of any stain used to colour the wood and prepare the surface for a new coat of finish. If the floor is badly marked and scratched and has to be sanded back to new wood use the HT8-1.2 Floor Sander and HT7-2 Disc Floor Sander. Always try a medium grade paper first, particularly on a diagonal cut. If 90% of the old finish is removed and the floor is generally leveled, you do not need to use a coarse grit abrasive.

### VENEERED, LAMINATED & THINNER FLOORS

Use the HTF-2 Floor Sander for veneered and laminated floors or thinner floors that may have been subjected to repeated sanding. The HTF-2 will remove old surface finishes and prepare the floor for re-finishing. Sand the floor using the same method as a strip, plank, or parquet floor. If the floor has deeper scratches or marks these should be sanded

out by hand and blended in with the main floor. To check the wood depth in the floor remove a baseboard or molding from around the edge of the floor. This should provide access to the edge of the floor for inspection.

### PARQUET & BLOCK FLOORS

The grain of the wood will run in a number of directions so sand the floor in the direction of the main source of natural light in the room. If there is no source of natural light sand in the direction of the longest side of the room or, if the room is square, in the direction the furniture is laid out and how people normally use and view the room.

This technique will help mask any imperfections in the

floor. Complete the sanding operation as detailed for plank or strip floors.

### BETWEEN COATS OF FINISH (VARNISH)

Use the HTF-2 Floor Sander to sand between coats of floor finish, particularly when using water based varnishes. These types of finishes tend to raise the wood grain when first applied to raw wood. Allow each coat of varnish to dry completely following the manufactures directions. Use Hiretech abrasive pads to sand between each coat of varnish. The fine abrasive pads will remove light brush/applicator marks and raised grain while maintaining the integrity of the coat of varnish applied.

### FLOOR SANDING TECHNIQUE

#### Level uneven floors.

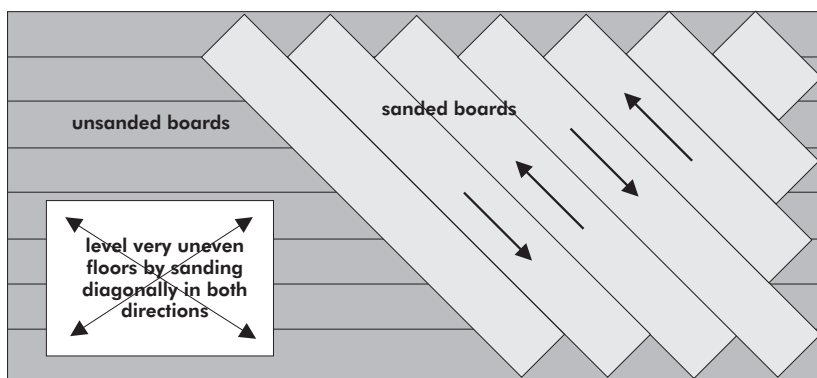

#### Sand main floor area.

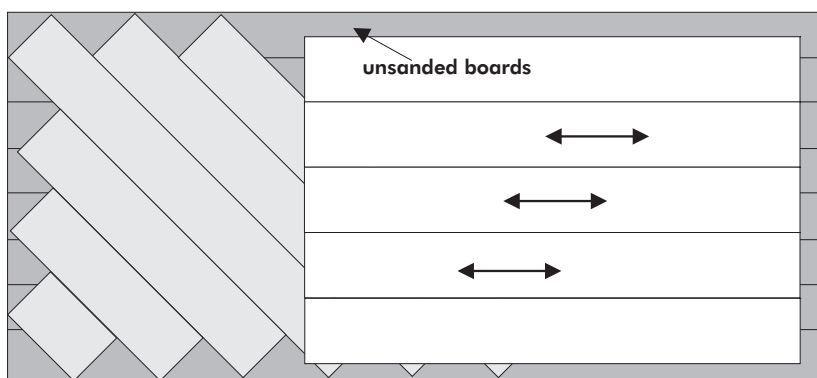

**Plank and Strip Floors** - sand in the direction the boards are laid, with the wood grain.

**Parquet and Wood Block Floors** - sand in the direction of the main source of natural light. If there is no natural source of light, sand in the direction of the longest side of the room. If the room is square, sand in the direction the furniture is laid out and how people normally use the room.

#### Sand and blend edges in with main floor area.

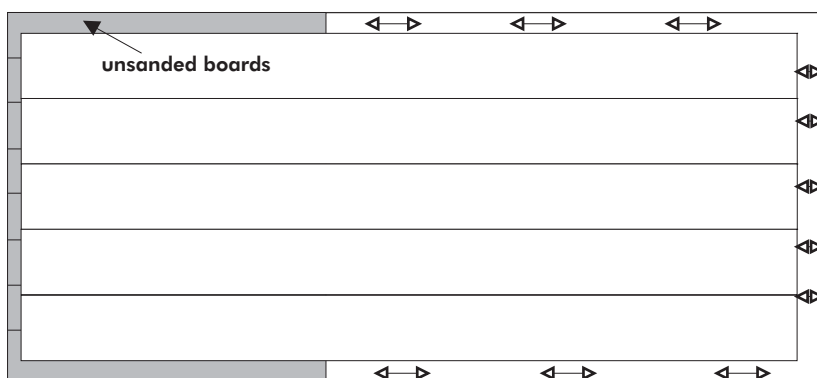



## HTF-2 FLOOR SANDER ABRASIVE GUIDE

ABRASIVE GRADE	APPLICATION	FLOOR TYPE
<b>Abrasive Sheet 40G (Coarse)</b>	For the rapid removal of stock and where a deep cut is required.	Use on solid raw wood floors.  Not recommended for use on factory finished or laminate flooring systems.
<b>Abrasive Sheet 60G (Medium)</b>	In progression from 40 grade to first sanding on smooth surfaces requiring less stock removal.  Removal of stains and old finish from the sub surface of the floor after stripping of surface coatings with 80 grade (medium) abrasive.	Solid raw wood floors, and floors where an existing stain or finish is to be completely removed from the wood prior to new finish being applied.
<b>Abrasive Sheet 80G (Medium)</b>	Medium stock removal.  Rapid removal of surface coatings and finishes.	Suitable for all floor types, however, care should be taken on factory pre-finished floors where the integrity of seals and stains should be maintained.
<b>Abrasive Sheet 120G (Fine)</b>	Light stock removal and where only a minor dimensional change is required in the floor surface.	First sanding of floors that require re-finishing without the removal of old surface coatings and where the integrity of seals and stains must be maintained.
<b>Abrasive Sheet 180G (Extra Fine)</b>	Negligible stock removal prior to application of finish.	Suitable for all floor types.
<b>Abrasive Pad 280G (Finishing)</b>  <b>Backing Pad</b>	Preparation for high quality finished Surface.  Flexible backing pad for abrasive sheets.	Suitable for all floor types.  Use to sand between coats of finish especially water based stains and varnishes.

DO NOT OVER-SAND USE ONLY AS HEAVY GRADE ABRASIVE AS IT TAKES TO DO THE JOB. PROGRESS FROM FIRST GRADE USED THROUGH FOLLOWING GRADES TO REMOVE ALL VISIBLE SANDING MARKS. DO NOT MISS A GRADE.

## SERVICE & ROUTINE MAINTENANCE



*CAUTION - maintenance and repairs must be carried out by authorized personnel only. To prevent injury, always remove the power cable from the power supply before undertaking any work on the machine. Do not operate this machine unless it is fully assembled and all guards are in place. Use Hiretech genuine spare parts only.*

### General

1. Always make a list when first examining the machine, to remind you of parts or action needed on completion of routine maintenance.
2. The HTF-2 Floor Sander is subject to high speeds and vibration, all screws should be fitted using a suitable thread lock compound.
3. The HTF-2 Floor Sander needs no lubrication during routine servicing.
4. Always ensure that the electrical supply is disconnected before starting any routine servicing or repair.
5. Follow a regular schedule of routine maintenance to keep your HTF-2 Floor Sander in good working.

### Visual Inspection

1. To clean the machine and remove dust, use a vacuum cleaner to avoid damage and prevent inhalation of dust.
2. Examine all external parts of the floor sander making sure there is no damage. Check the condition of the Dust Brush and Bumper around the base of the floor sander, both of which should be undamaged and in good condition. Check that the Handle Yoke unlocks and moves freely in its operating position.
3. Examine the sanding pads. These should be undamaged and in good condition. They should fit firmly to the fixing posts and pivot slightly forward and back.
4. Examine the power cable for damage. If the outer insulation shows the slightest of abrasions or the inner conductors are exposed then the cable must be replaced. The cable must not be repaired with tape or insulation sleeve.
5. Ensure all labels are sound, readable and secure.
6. Check that the rear wheels are sound and moving freely. If a wheel is found to be loose or damaged then the floor sander will not sand or handle properly. Check and reset the wheels (see

Setting the Wheels on page 8). Replace damaged wheels.

7. Check the condition of the Dust Bag Frame making sure that it hinges down in to its operating position and locks securely when stowed.

### Dust Control

1. Remove the handle and lay the floor sander on its face. Remove the sanding pad if fitted and inspect the underside for the build up of dust or pieces of abrasive. Clean as required.
2. Inspect the condition of the Dust Brush. The brush should be replaced if damaged or badly worn.

### Drive

1. The drive gears and drive belt do not require maintenance under normal operating conditions.

### Lubrication

1. The HTF-2 Floor Sander features sealed for life bearings which do not require any lubrication. In the unlikely event that a bearing has to be replaced use a Hiretech genuine spare part only as the grease contained in the bearings is special. A standard bearing is not suitable and may result in further damage.

### Care of Motor

1. The motor must be kept clean and free from grease and dust.
2. The motor brushes must be checked regularly. Replace ALL FOUR motor brushes when any one brush has worn to 12mm ( $\frac{15}{32}$ " ) or less in length. Brushes MUST slide freely in the brush holders.

There is no need to remove or disconnect any internal leads when changing the brushes, only the small braided shunt (pigtail) connected to the motor brush is disconnected to release the brush.

3. To replace the motor Brushes ;
  - (1) Remove the four screws from the Motor Cover and lift the cover off.
  - (2) Remove the four Spring Brushes and set to one side. The springs are removed by pushing the spring tag in towards the brush and lifting out.
  - (3) Using a cross recess screwdriver remove the four brush shunt (pigtail) retaining screws and lock washers.
  - (4) Remove the four brushes.

- (5) Thoroughly clean the brush assembly and housing using a soft brush and a suitable vacuum cleaner.
  - (6) Inspect the four brushes for damage or wear and if any one brush is found to be damaged or worn to a length of 12mm ( $\frac{15}{32}$ " ) or less in length then replace all four brushes. Always replace all four brushes together.
  - (7) When replacing brushes ensure that each brush moves freely in each brush holder and fit the brush with the shunt (pigtail) in such a position as to allow free movement throughout the brushes life. Ensure that each brush shunt is connected securely with the screw and lock washer (two spare screws and washers are provided with each pack of brushes). The brush should be fitted so that the brush shunt (pigtail) is at the bottom of the brush.
  - (8) Refit the brush springs by inserting into the holder with the coil spring over the brush then push in until the tag comes into contact with the holder, slide the tag away from the brush and release. The brush spring will clip into position. Check the springs and brushes for correct alignment and free movement.
  - (9) Finally check that all leads and cables are clear of moving parts and will not be trapped when refitting the cover motor.
  - (10) Refit the cover motor and secure with the four screws.
4. Place a straight edge, a steel rule is best, across the center of one wheel and the block of wood. If the wheels are adjusted correctly there will be no gap across the whole width of the block. If you see a gap the wheels need adjustment.  
If the gap is at the rear of the block toward the back of the floor sander, the wheels are too low. If the gap is at the front of the block, toward the front of the floor sander the wheels are too high.
  5. If the wheels need adjustment. Loosen the Axle Clamp screws located under the axle which will be facing you when the floor sander is upside down resting on the motor cover.
  6. Rotate the axle via the socket head screw located in the center of the wheels. As you rotate the axle via the socket head screw the wheels will rise or fall. Adjust the wheels so that the straight edge rests on the center of the wheels and the wood block so that there is no gap across the whole width of the block.
  7. When the wheels are correctly adjusted tighten the axle clamp screws. Check the socket head screws in the center of the wheels are tight.

## ELECTRICAL TESTING



*CAUTION - testing for electrical safety should only be undertaken by a competent person and all results recorded. Do not exceed 1250 volt insulation test duration of 3 seconds*

### Setting the Wheels



*CAUTION - under normal operating conditions the wheels should not have to be adjusted. However, should you suspect the wheels have gone out of adjustment follow the procedure below to check and reset the wheels.*

1. Remove the handle and turn the floor sander upside down so that it rests on the motor cover. Take care, the floor sander is heavy and can easily over balance. Make sure that it is well supported.
  2. Fit the sanding block to the floor sander, making sure that it is firmly seated.
  3. Place a block of wood or other solid material on the face of the sanding block 16mm ( $\frac{5}{8}$ " ) high by 114mm ( $4\frac{1}{2}$ " ) wide across the full width of the sanding block.
1. Examine the power cable for damage. If the outer insulation shows the slightest of abrasions or the inner conductors are exposed then the cable must be replaced. The cable must not be repaired with tape or insulation sleeve.
  2. Open and check the mains plug for condition, loose connections, damaged wires etc. Ensure that the strain relief of the plug is correctly secured to the outer cable insulation. This does not apply if the plug is molded on to the power cable.
  3. Remove the question switch housing screws and lift separate the switch housing. Check the switch, connections, leads etc. Pay special attention to any gaskets, 'O' rings and seals intended to exclude dust from the switch and switch housing area. These must be maintained in good condition.  
Carefully brush and vacuum clean the switch housing.
  4. Refit the switch housing taking care not to trap any leads.

5. Using a piece of insulation tape or a small soft wedge lock the bias off switch in the 'ON' position.
6. Use the standard procedure test for electrical safety. Do not exceed 1250 volt insulation test duration of 3 seconds.
5. Record the test results.
6. Complete a functional (run) test and record results.



**CAUTION** - when undertaking a functional (run) test make sure the machine is secure. Remember the sanding pad will rotate.

## FAULT FINDING

FAULT	CAUSE	ACTION
The machine does not run.	The power cable is not connected to the power supply. The motor brushes are worn. The voltage is too low.	Connect the power cable to the power supply. Replace the motor brushes. Check the main power complies with the machine's serial plate data.
The machine will not pickup dust.	The dust bag is full.  There is an obstruction in the dust pick-up.  The dust brush is worn.	Replace the paper dust bag or empty the cloth dust bag.  Disconnect the machine from the power supply, tip the machine back and remove the sanding pad, check for obstruction.  Replace the dust brush.
The machine does not sand evenly.	The sanding pad is damaged.  The wheels are out of adjustment.	Check and replace the sanding pad.  Check and adjust the wheels.
The sander does not glide easily in a straight line.	The machine is not being operated properly. The wheels are out of adjustment. The Abrasive Pad is worn.	Read the instructions, do not apply pressure when sanding. Check and adjust the wheels.  Replace the Abrasive Pad
The machine runs slow.	The voltage is low.  A motor brush is not making contact.	Check the supply voltage.  If an extension lead is being used, is it undersize and/or is it coiled.  Check and refit or replace the motor brushes.

# HTF-2 PARTS DIAGRAM

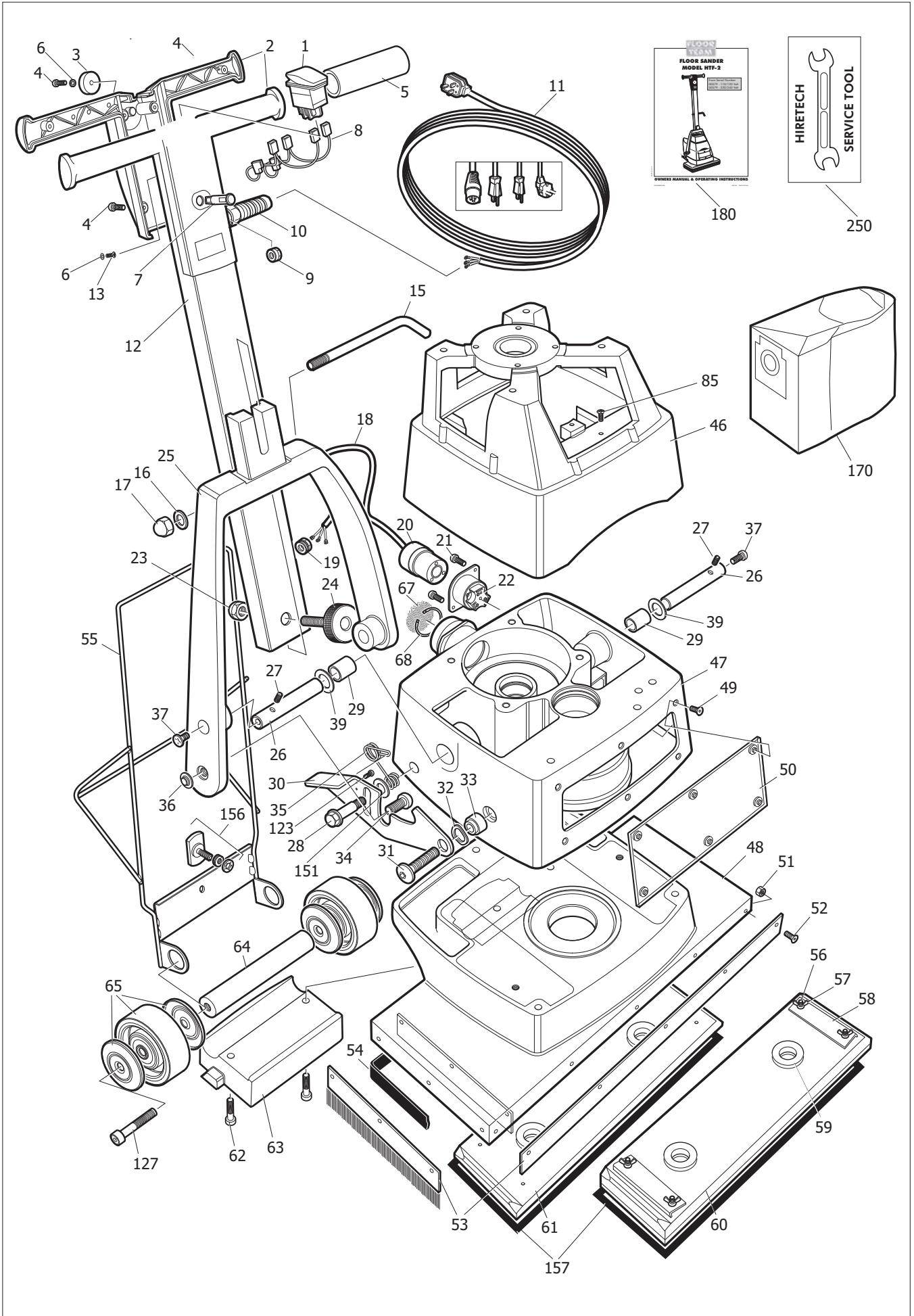



# HTF-2 PARTS DIAGRAM

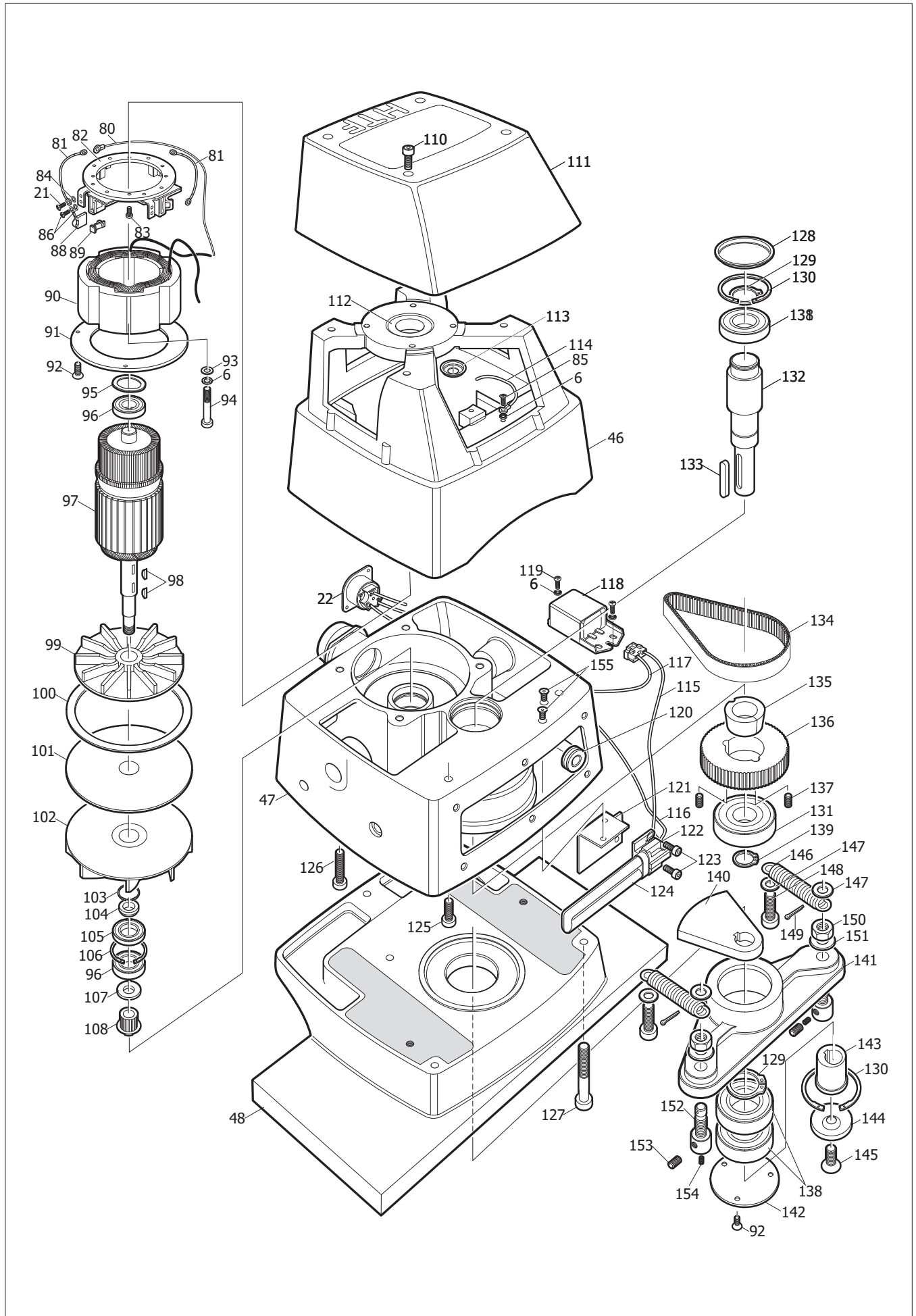



## PARTS LIST HTF-2

Ref.	PSTK	Pack Qty.	Description	Ref.	PSTK	Pack Qty.	Description
1	011600	1	Switch 220/240 Volt (Bias Off)	53	030360	1	Brush Set
1	011610	1	Switch 110/120 Volt (Bias Off)	54	030350	1	Bumper
2	030425	1	Housing Switch Assembly	55	030300	1	Support Bag (check Serial No.)
3	030630	1	Stop Rubber	56	031010	4	Bolt
4	030920	7	Screw	57	031020	4	Wing Nut
5	031870	2	Grip Hand	58	030390	2	Clamp Abrasive
6	010270	5	Washer Lock	59	030400	2	Bush
7	030640	1	Lamp Neon 110/120 Volt	60	030370	1	Sanding Block
7	030650	1	Lamp Neon 220/240V	61	030380	1	Sanding Block Abrasive Pad
8	030950	2	Lead Neon	62	030790	4	Screw
9	101206	1	Nut Lock	63	030060	1	Retainer Wheel
10	101205	1	Strain Relief	64	030320	1	Housing Eccentric
11	030660	1	Cable Main Assembly 110 Volt (NA)	65	030070	2	Wheel
11	030670	1	Cable Main Assembly 220/240 Volt (UK)	67	031420	1	Exhaust Guard
11	030680	1	Cable Main Assembly 110 Volt (UK)	68	031430	1	Ring Retainer
11	030690	1	Cable Main Assembly 220 Volt (EEC)	80	030990	1	Lead Motor
11	030700	1	Cable Main Assembly 220/240V (AUS)	81	010750	2	Brush Shunt
12	030910	1	Tube Handle Assembly	82	010170	1	Brush Block Assembly
13	962345	10	Screw	83	010190	4	Screw Pack of 4
15	164508	1	Hook Cable	84	010200	4	Washer
16	980197	1	Washer	86	010220	4	Screw and Washer Set
17	920148	1	Nut	88	010180	4	Brush Motor
18	030930	1	Handle Cable (NA)	89	010230	4	Brush Spring
18	030940	1	Handle Cable	90	032000	1	Field 110/120 Volt HTF
18	031000	1	Handle Cable 110 Volt (UK)	90	032010	1	Field 220/240 Volt HTF
19	101220	1	Strain Relief Handle Cable	91	010290	1	Baffle
19	163804	1	Strain Relief Handle Cable (NA)	92	010300	3	Screw
20	911046	1	Body Twist Lock	93	010260	2	Washer Clamp
21	010210	4	Screw	94	010280	2	Screw
22	031400	1	Base Twist Lock	95	010600	1	Spring Load
23	031910	1	Nut	96	010320	2	Bearing
24	030450	1	Clamp Handle	97	010330	1	Armature 110/120 Volt
25	030042	1	Handle Frame	97	010340	1	Armature 220/240 Volt
26	031790	2	Pin Pivot	98	010350	3	Key
27	031160	2	Screw	99	010360	1	Fan Motor
28	031900	1	Bolt	100	010370	1	Gasket
29	031800	2	Bush Bearing	101	010380	1	Plate Exhaust
30	030222	1	Latch	102	010390	1	Fan Intake
31	031810	1	Screw	103	010400	1	Ring Retainer
32	031890	1	Washer	104	010410	1	Spacer Bearing
33	031880	1	Spacer Latch Pivot	105	010420	1	Seal
34	031820	1	Screw	106	010430	1	Ring Retainer
35	031840	1	Spring Latch Return	107	031520	1	Spacer Pulley
36	031830	1	Cover Screw	108	030180	1	Pulley Drive
37	031850	2	Screw	110	010010	4	Screw
39	030550	2	Washer	111	030090	1	Cover Motor
46	030030	1	Housing Motor	112	011840	1	Insert Bearing
47	030022	1	Housing Gear	113	031280	1	Bush Insulator
48	030010	1	Housing Lower	114	031070	1	Lead Ground (Earth)
49	031090	6	Screw	115	031040	1	Lead Lamp/Ballast
50	030270	1	Window Lamp	116	031050	1	Lead Lamp/Twistlock
51	031130	16	Nut	117	031060	1	Lead Ballast/Twistlock
52	031120	16	Screw	118	030710	1	Ballast Start 220/240 Volt

## PARTS LIST HTF-2

Ref.	PSTK	Pack Qty.	Description	Ref.	PSTK	Pack Qty.	Description
118	030720	1	Ballast Start 110/120 Volt	145	030780	1	Screw
119	163838	2	Screw	146	030520	2	Spring Sanding Pad
120	163808	1	Grommet	147	980629	1	Washer
121	030280	1	Plate Lamp	148	030830	2	Screw
122	030730	1	Holder Lamp	149	010680	1	Pin Cotter
123	030760	3	Screw	150	030850	2	Nut
124	030750	1	Lamp	151	030860	3	Washer
125	030740	2	Screw	152	030100	2	Pin
126	031450	4	Screw	153	030600	2	Spring Plunger
127	030820	7	Screw	154	030840	2	Screw
128	031300	1	Plug Bearing	155	030770	2	Screw
129	030480	2	Clip	156	031650	1	Knob Assembly
130	030490	2	Clip	157	031370	1	Hook and Loop Pad
131	030470	1	Bearing	170	07038	25	Disposable Paper Dust Bag HT7/HTF Pack 2 (box 25)
132	030130	1	Shaft Drive	170	07040	50	Disposable Paper Dust Bag HT7/HTF (box 50)
133	030510	1	Key	180	031390	1	Owners Manual & Operating Instructions
134	030150	1	Belt Drive				
135	030170	1	Bush Pulley				
136	030190	1	Pulley Driven				
137	031170	2	Screw				
138	030460	3	Bearing				
139	030500	1	Clip				
140	030120	1	Balance Weight				
141	030080	1	Holder Sanding Pad				
142	030410	1	Plate Cover				
143	030110	1	Bush Eccentric				
144	030440	1	Cap Retaining				

  

<b>Special Tools (not illustrated)</b>							
250	011740	1	Service Tool - Pinion & Pulley Fitting/Removal				
250	031490	1	Service Tool - Lever Block Holder HTF				
250	031610	1	Service Tool - Jacking Bolts HTF				

## FLOOR SANDER ABRASIVES

<b>Hiretech Abrasives</b>	HT8/DJ8 FLOOR SANDER SHEET 20 & 50/CASE	HT8 EX FLOOR SANDER BELTS 5/CASE	HT7/SUPER 7 EDGER DISC FIBRE BACKED 25/CASE	HT7/SUPER 7 EDGER DISC PAPER BACKED 25 & 50/CASE	HTF FLOOR SANDER SHEET ADHESIVE BACKED 25 & 50/CASE	HTF ABRASIVE PAD 20/CASE
Hiretech recommend the following abrasive range which are suitable for all floor types and applications.						
P16	-	-	01025	-	-	-
P24 Grit Open Coat	01001	-	-	01044	-	-
P24 Grit	01002	01010	01026	-	-	-
P36 Grit	-	01011	-	-	-	-
P40 Grit	01003	01012	-	01045	01750	-
P50 Grit	-	01013	01027	-	-	-
P60 Grit	-	01014	-	-	01751	-
P80 Grit	01004	01015	01028	01046	01752	-
P100 Grit	-	01016	-	-	-	-
P120 Grit	01005	01017	01030	01048	01754	-
P150 Grit	-	01018	-	-	-	-
P180 Grit	-	-	-	-	01756	-
P280 Grit/Backing Pad	-	-	-	-	-	01769

# HTF-2 CIRCUIT DIAGRAM

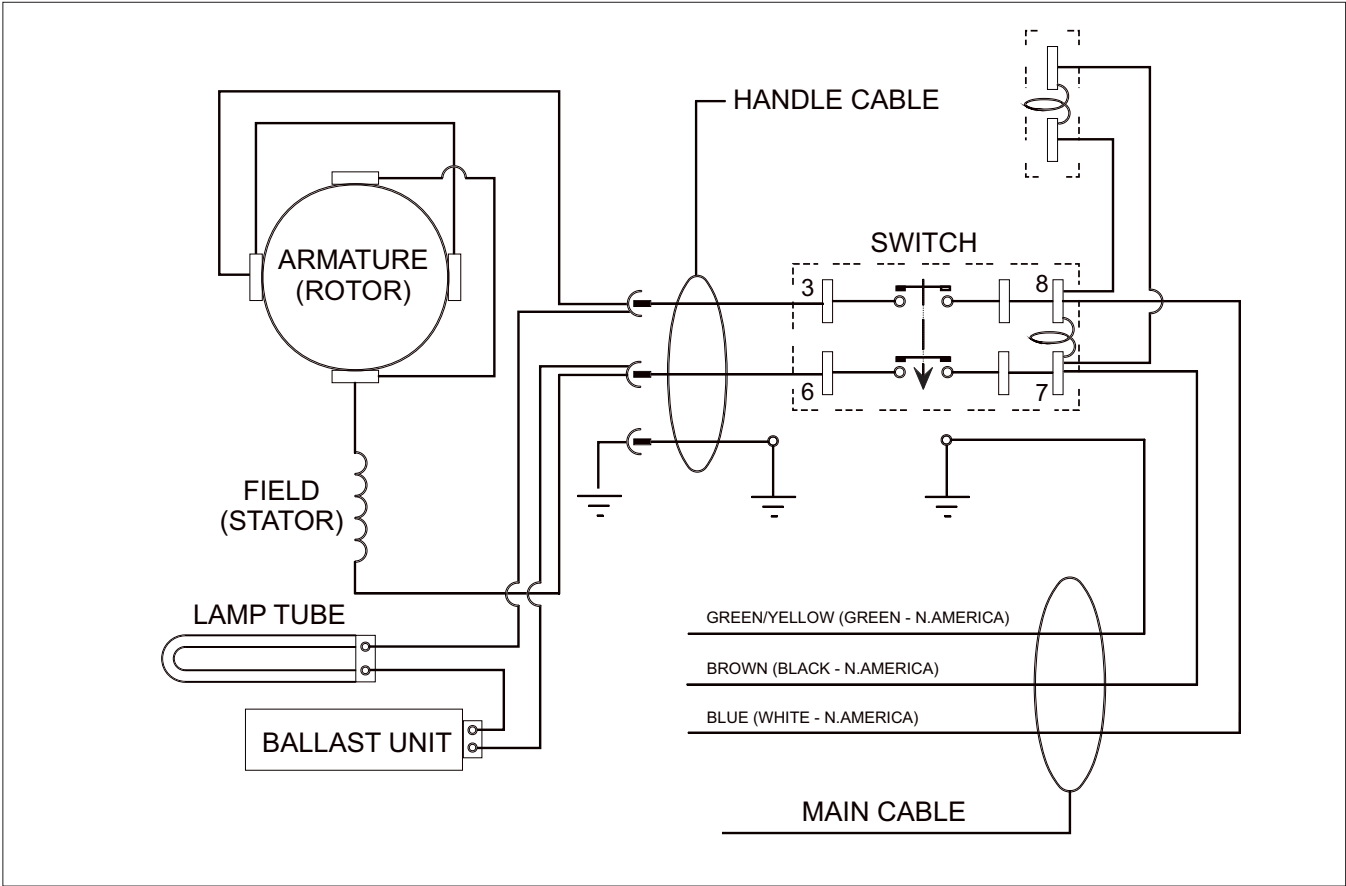

## DECLARATION OF CONFORMITY

This declaration identifies the product, manufacturer's name and address, and applicable specifications recognised in the European community.

### DECLARATION OF CONFORMITY



**Manufacturer's Name:** Hire Technicians Group Ltd.

**Manufacturer's Address:** Chalk Hill House  
8 Chalk Hill  
Watford  
Herts WD1 4BH

**declares that the product:**

**Product Name:** Hiretech Floor Sander

**Model Name:** **HTF-2** 230 Volt 50Hz Insulation Class 1  
**HTF-2** 110 Volt 50Hz Insulation Class 1

**conforms to the following:**

Machinery Directive (Harmonised)	89/392-EU as amended
Low Voltage Directive (Harmonised)	73/23/EU as amended
Electromagnetic Compatibility Directive	89/336/EU as amended

**following the provisions of the directives:**

89/392/EU, 93/44EU, 73/23/EU, 93/68/EU, 89/336/EU, 91/368/EU,  
92/31/EU

EN60 335-1-88 (HD 251-1-3) BS 3456-201	EN292-1-91
EN292-2-91	EN60204-1-92
EN55014-93 (BS 800)	EN 50082-1-92
IEC 745-2-4 (HD 400.2) (BS 2769-2-2.4)	

**electrical safety test procedures comply with:**

IEC 335 pt. 1-2, HD251 1-3 1982, BS 2769 & 3456, CSA C22.2,  
KEMA K78A1/W1 & W3, NEMKO 503./89, DIN VDE 0700 1/04.88  
HD 264.S2 15/07.86

Where the product is licensed to carry a National Approval Mark it is certified that all such products comply with the terms of that license.

C.J. Hedger, Director of Engineering. 1 April 2012

## SERVICE & REPAIR

Contact your reseller for the name of your local service agent. Service and repairs undertaken by non-approved service agents will void the product warranty. If you should have difficulty in obtaining service please contact your distributor nearest to you at the address given below.

For the latest list of Hiretech dealers check on the Hiretech web site at [www.hiretech.biz/contact/dealerlist.html](http://www.hiretech.biz/contact/dealerlist.html).

Name	Address	Telephone, Facsimile, Email & Web
Hiretech Pty Ltd	Unit 2 62 Owen Street Glendenning NSW 2761 AUSTRALIA	Tel: +61 29625 9337 Fax: +61 29625 4770 Email: <a href="mailto:sales@hiretech.com.au">sales@hiretech.com.au</a> Web: <a href="http://www.hiretech.com.au">www.hiretech.com.au</a>
Abmast Inc (Canada East)	6935 Rue Picard Saint-Hyacinthe QC J2S 1H3 CANADA	Tel: (800) 361-0854 Fax: (800) 341 0554 Email: <a href="mailto:asimard@abmast.com">asimard@abmast.com</a> Web: <a href="http://www.abmast.com">www.abmast.com</a>
S T C as Praha	Konevova 33 130 00 Praha 3 CZECH REPUBLIC	Tel: + 4202 22585810 Fax: +42 02 22584421 Email: <a href="mailto:ruzena.muzikantova@stcnet.cz">ruzena.muzikantova@stcnet.cz</a>
Tool Matic A/S	Vedskollevej Herfolge 4681 DENMARK	Tel: +45 56250708 Fax: +45 56250705 Email: <a href="mailto:sales@tool-matic.dk">sales@tool-matic.dk</a> Web: <a href="http://www.tool-matic.dk">www.tool-matic.dk</a>
VIF Diffusion	rue du Chateau-BP70112 59052 Roubaix Cedex 1 FRANCE	Tel: +33 320 207880 Fax: +33 320 207889 Email: <a href="mailto:infos@vif-furniture.com">infos@vif-furniture.com</a>
Tucks Limited	Hume Avenue Park West Industrial Estate Dublin 12 REPUBLIC OF IRELAND	Tel: +353 (01) 621 5555 Fax: +353 (01) 621 5563 Email: <a href="mailto:info@tucks.ie">info@tucks.ie</a> Web: <a href="http://www.tucks.ie">www.tucks.ie</a>
Turner Morris (Pty) Ltd	39 Robyn Road Benrose P.O. Box 27252 2011 SOUTH AFRICA	Tel: +27 11 618 4313 Fax: +27 11 618 2620 Email: <a href="mailto:dbnsales@turnermorris.co.za">dbnsales@turnermorris.co.za</a> Web: <a href="http://www.turnermorris.co.za">www.turnermorris.co.za</a>
Hire Technicians Group Ltd	Chalk Hill House 8 Chalk Hill Watford Herts WD1 4BH UNITED KINGDOM	Tel: +44 01923 252230 Fax: +44 01923 238799 Email: <a href="mailto:sales@hiretech.biz">sales@hiretech.biz</a> Web: <a href="http://www.hiretech.biz">www.hiretech.biz</a>
Hiretech North America Inc	PO Box 1564 Cliffotn Park NY 12065 USA	Tel: +1 518 348 1300 (800) 563 2472 Fax: +1 518 348 1400 (800) 465 5981 Email: <a href="mailto:sales.usa@hiretech.biz">sales.usa@hiretech.biz</a> Web: <a href="http://www.hiretech.biz">www.hiretech.biz</a>

## **HIRETECH LIMITED WARRANTY**

Hiretech warrants to the original purchaser that the Hiretech machine covered by this warranty is free from defects in workmanship and materials. Should any part fail in the period of two years from the date of the original purchase as a result of a defect, Hiretech will (at it's option) either repair or replace the part without charge provided that the machine has been operated in accordance with the Owners Manual and Operating Instructions.

Should any such defect arise, please contact your nearest authorised repair agent. Standard service over land mainland freight costs will be refunded on warranty repairs at the sole discretion of Hiretech or the authorised repair agent. If the repair is non-warranty, the customer will be advised before any work is undertaken.

This warranty is the sole warranty by Hiretech and is in lieu of all other warranties express or implied and releases Hiretech from all other obligations and liabilities.

This warranty does not apply to normal wear and tear to the machine, and in particular does not cover normal wear parts such as mains cable, wheels, switches, relays, brushes, rubber parts, hoses and bearings. This warranty also does not cover, and Hiretech will not be liable for, excessive wear caused by abnormal use.

Hiretech will under no circumstances be liable for alterations to the machine or for damage caused by third persons, or for misuse or abuse of the machine, or damage caused during transportation. Repairs of the machine made or attempted by persons other than those specifically authorised by Hiretech shall render this warranty void and Hiretech will not be liable for such repairs, the cost of such repairs, or the consequences of such repairs. Where spare parts are used on the machine and they do not conform to Hiretech specifications, this warranty will be rendered void and Hiretech will not be liable.

Hiretech will not be liable for any indirect or consequential loss, damage, cost or expense of any kind whatever and however caused whether arising under contract, tort (including negligence) or otherwise including (without limitation) loss of production, loss of profits or contracts or of operating time or goodwill or anticipated savings.

*Every effort has been made to present all information in this publication accurately, however no liability is accepted for any inclusions or advice given or for omissions from this publication. Hiretech reserves the right to make changes or improvements to its products without prior notice. Hiretech<sup>®</sup> is a registered trademark of Hire Technicians Group Ltd., all other trademarks are the property of their respective owners.  
© Hire Technicians Group Ltd.*



MANUFACTURED BY

**HIRE TECHNICIANS GROUP LIMITED**  
**CHALK HILL HOUSE, 8 CHALK HILL, WATFORD,**  
**HERTS, WD19 4BH. UNITED KINGDOM**

**TEL: +44 (0)1923 332424 FAX: +44 (0)1923 332425**  
**E-mail: sales@hiretech.biz Web: www.hiretech.biz**