

0111922	004
1004	en

Single Direction Plates

WP 1550A/AW

WP 1550R/RW

WP 1550V/VW

WP 1550/W

WP 1540A/AW

WP 1540/W

REPAIR MANUAL



0 1 1 1 9 2 2

1. Foreword	3
2. Safety Information	6
2.1 Laws Pertaining to Spark Arresters	6
2.2 Operating Safety	7
2.3 Operator Safety while using Internal Combustion Engines	8
2.4 Service Safety	9
3. Technical Data	10
3.1 WP 1550A/AW	10
3.2 WP 1550R/RW	11
3.3 WP 1550V/VW	12
3.4 WP 1540A/AW	13
3.5 WP 1550/W	14
3.6 WP 1540/W	15
4. General	16
4.1 Application	16
4.2 General Description	16
4.3 Periodic Maintenance Schedule	17
5. Baseplate	18
5.1 Exploded View	18
5.2 Guide Handle	21
5.3 Frame-Lifting Cage	22
5.4 Drive Belt	23
5.5 Engine	25

6. Exciter	26
6.1 Exciter Exploded View	26
6.2 Lower Belt Guard	28
6.3 Exciter	29
6.4 Exciter Components	30
7. Clutch	33
7.1 Clutch Assembly Exploded View	33
7.2 Clutch	34
7.3 Clutch Components	35
7.4 Clutch Engagement Speed Test	36
8. Water System	37
8.1 Water System Exploded View	37
9. Troubleshooting	39

CALIFORNIA

Proposition 65 Warning:



Engine exhaust, some of its constituents, and certain vehicle components contain or emit chemicals known to the State of California to cause cancer and birth defects or other reproductive harm.

1. Foreword

This manual provides information and procedures to safely operate and maintain this Wacker model. For your own safety and protection from injury, carefully read, understand and observe the safety instructions described in this manual.

Keep this manual or a copy of it with the machine. If you lose this manual or need an additional copy, please contact Wacker Corporation. This machine is built with user safety in mind; however, it can present hazards if improperly operated and serviced. Follow operating instructions carefully! If you have questions about operating or servicing this equipment, please contact Wacker Corporation.

The information contained in this manual was based on machines in production at the time of publication. Wacker Corporation reserves the right to change any portion of this information without notice.

All rights, especially copying and distribution rights, are reserved.

Copyright 2004 by Wacker Corporation.

No part of this publication may be reproduced in any form or by any means, electronic or mechanical, including photocopying, without express written permission from Wacker Corporation.

Any type of reproduction or distribution not authorized by Wacker Corporation represents an infringement of valid copyrights and will be prosecuted. We expressly reserve the right to make technical modifications, even without due notice, which aim at improving our machines or their safety standards.

Notes:

This manual covers machines with Item Number:

**0007576, 0007576, 0007577, 0007578, 0007578, 0007579, 0007579,
0007580, 0007581, 0007581, 0008060, 0008061, 0009324, 0009325,
0009326, 0009327, 0009472, 0009486**

Operating / Parts Information

You must be familiar with the operation of this machine before you attempt to troubleshoot or make any repairs to it. Basic operating and maintenance procedures are described in the Operator's Manual supplied with the machine. Keep a copy of it with the machine at all times. Use the separate Parts Book supplied with the machine to order replacement parts. If either of the documents becomes lost, please contact Wacker Corporation to order a replacement.

Damage caused by misuse or neglect of the unit should be brought to the attention of the operator, to prevent similar occurrences from happening in the future.

This manual provides information and procedures to safely repair and maintain the above Wacker model(s). For your own safety and protection from injury, carefully read, understand, and observe all instructions described in this manual. THE INFORMATION CONTAINED IN THIS MANUAL IS BASED ON MACHINES MANUFACTURED UP TO THE TIME OF PUBLICATION. WACKER CORPORATION RESERVES THE RIGHT TO CHANGE ANY PORTION OF THIS INFORMATION WITHOUT NOTICE.

2. Safety Information

This manual contains DANGER, WARNING, CAUTION, and NOTE callouts which must be followed to reduce the possibility of personal injury, damage to the equipment, or improper service.



This is the safety alert symbol. It is used to alert you to potential personal injury hazards. Obey all safety messages that follow this symbol to avoid possible injury or death.



DANGER

DANGER indicates an imminently hazardous situation which, if not avoided, will result in death or serious injury.



WARNING

WARNING indicates a potentially hazardous situation which, if not avoided, could result in death or serious injury.



CAUTION

CAUTION indicates a potentially hazardous situation which, if not avoided, may result in minor or moderate injury.

CAUTION: Used without the safety alert symbol, CAUTION indicates a potentially hazardous situation which, if not avoided, may result in property damage.

Note: *Contains additional information important to a procedure.*

2.1 Laws Pertaining to Spark Arresters

Notice: State Health Safety Codes and Public Resources Codes specify that in certain locations spark arresters be used on internal combustion engines that use hydrocarbon fuels. A spark arrester is a device designed to prevent accidental discharge of sparks or flames from the engine exhaust. Spark arresters are qualified and rated by the United States Forest Service for this purpose.

In order to comply with local laws regarding spark arresters, consult the engine distributor or the local Health and Safety Administrator.

2.2 Operating Safety



Familiarity and proper training are required for the safe operation of equipment! Equipment operated improperly or by untrained personnel can be dangerous! Read the operating instructions contained in both this manual and the engine manual and familiarize yourself with the location and proper use of all controls. Inexperienced operators should receive instruction from someone familiar with the equipment before being allowed to operate the machine.

- 2.2.1 NEVER allow anyone to operate this equipment without proper training. People operating this equipment must be familiar with the risks and hazards associated with it.
- 2.2.2 NEVER touch the engine or muffler while the engine is on or immediately after it has been turned off. These areas get hot and may cause burns.
- 2.2.3 NEVER use accessories or attachments that are not recommended by Wacker. Damage to equipment and injury to the user may result.
- 2.2.4 NEVER operate the machine with the beltguard missing. Exposed drive belt and pulleys create potentially dangerous hazards that can cause serious injuries.
- 2.2.5 NEVER leave machine running unattended.
- 2.2.6 ALWAYS be sure operator is familiar with proper safety precautions and operation techniques before using machine.
- 2.2.7 ALWAYS wear protective clothing appropriate to the job site when operating equipment.
- 2.2.8 ALWAYS wear hearing protection when operating equipment.
- 2.2.9 ALWAYS close fuel valve on engines equipped with one when machine is not being operated.
- 2.2.10 ALWAYS store equipment properly when it is not being used. Equipment should be stored in a clean, dry location out of the reach of children.
- 2.2.11 ALWAYS operate machine with all safety devices and guards in place and in working order. DO NOT modify or defeat safety devices. DO NOT operate machine if any safety devices or guards are missing or inoperative.
- 2.2.12 ALWAYS read, understand, and follow procedures in Operator's Manual before attempting to operate equipment.

2.3 Operator Safety while using Internal Combustion Engines



DANGER

Internal combustion engines present special hazards during operation and fueling! Read and follow warning instructions in engine owner's manual and safety guidelines below. Failure to follow warnings and safety guidelines could result in severe injury or death.

- 2.3.1 DO NOT run machine indoors or in an enclosed area such as a deep trench unless adequate ventilation, through such items as exhaust fans or hoses, is provided. Exhaust gas from the engine contains poisonous carbon monoxide gas; exposure to carbon monoxide can cause loss of consciousness and may lead to death.
- 2.3.2 DO NOT smoke while operating machine.
- 2.3.3 DO NOT smoke when refueling engine.
- 2.3.4 DO NOT refuel hot or running engine.
- 2.3.5 DO NOT refuel engine near open flame.
- 2.3.6 DO NOT spill fuel when refueling engine.
- 2.3.7 DO NOT run engine near open flames.
- 2.3.8 ALWAYS refill fuel tank in well-ventilated area.
- 2.3.9 ALWAYS replace fuel tank cap after refueling.
- 2.3.10 ALWAYS check fuel lines and fuel tank for leaks and cracks before starting engine. Do not run machine if fuel leaks are present or fuel lines are loose.

2.4 Service Safety

**WARNING**

Poorly maintained equipment can become a safety hazard! In order for the equipment to operate safely and properly over a long period of time, periodic maintenance and occasional repairs are necessary.

- 2.4.1 DO NOT attempt to clean or service machine while it is running. Rotating parts can cause severe injury.
- 2.4.2 DO NOT crank a flooded engine with the spark plug removed on gasoline-powered engines. Fuel trapped in the cylinder will squirt out the spark plug opening.
- 2.4.3 DO NOT test for spark on gasoline-powered engines, if engine is flooded or the smell of gasoline is present. A stray spark could ignite fumes.
- 2.4.4 DO NOT use gasoline or other types of fuels or flammable solvents to clean parts, especially in enclosed areas. Fumes from fuels and solvents can become explosive.
- 2.4.5 ALWAYS keep area around muffler free of debris such as leaves, paper, cartons, etc. A hot muffler could ignite them, starting a fire.
- 2.4.6 ALWAYS replace worn or damaged components with spare parts designed and recommended by Wacker.
- 2.4.7 ALWAYS disconnect spark plug on machines equipped with gasoline engines, before servicing, to avoid accidental start-up.
- 2.4.8 ALWAYS keep machine clean and labels legible. Replace all missing and hard-to-read labels. Labels provide important operating instructions and warn of dangers and hazards.

3. Technical Data

3.1 WP 1550A/AW

		WP 1550A/AW 0007576, 0007579, 0009486
Plate		
Operating Weight	kg (lbs.)	86 (190)
Water Tank Capacity	l (qts.)	10.4 (11.0)
Exciter Speed	rpm / belt	5800
Exciter Lubrication	ml (oz.)	150 (5) Automatic Transmission Fluid Dextron III / Mercon or equivalent
Dimensions	mm (in.)	875 (35) x 500 (20) x 965 (38)

		WP 1550A/AW 0007576, 0007579, 0009486
Engine		
Engine Make		Honda
Engine Model		GX 160 K1 QWXZ
Rated Power	kW (Hp)	4.1 (5.5)
Spark Plug	type	NGK BPR 6ES
Electrode Gap	mm (in.)	0.7 – 0.8 (0.028 – 0.031)
Engine Speed - full	rpm	3600 ± 50
Engine Speed - idle	rpm	1600 ± 100
Clutch Engagement	rpm	2100
Air Cleaner	type	Dual Element
Engine Lubrication	oil grade	SAE 10W30
	service class	SG or SF
Engine Oil Capacity	ml (oz.)	600 (20)
Engine Oil Capacity	ml (oz.)	Regular unleaded gasoline
Fuel Tank Capacity	l (qts.)	3.7 (3.9)
Valve Clearance (cold)	mm (in.)	Inlet: 0.15 (0.006) Outlet: 0.20 (0.008)

3.2 WP 1550R/RW

		WP 1550R/RW 0007578, 0007581
Plate		
Operating Weight	kg (lbs.)	88 (194)
Water Tank Capacity	l (qts.)	10.4 (11.0)
Exciter Speed	rpm / belt	5800
Exciter Lubrication	ml (oz.)	150 (5) Automatic Transmission Fluid Dextron III / Mercon or equivalent
Dimensions	mm (in.)	686 (27) x 508 (62) x 965 (38)

		WP 1550R/RW 0007578, 0007581
Engine		
Engine Make		Robin
Engine Model		EH17
Rated Power	kW (Hp)	4.5 (6.0)
Engine Speed - full	rpm	3600 ± 100
Engine Speed - idle	rpm	1600 ± 100
Clutch Engagement	rpm	2100
Spark Plug	type	NGK B6HS
Electrode Gap	mm (in)	0.5–0.76 (0.020–0.030)
Air Cleaner	type	Dual Element
Engine Lubrication	oil grade	SAE 10W30
	service class	SC or higher
Engine Oil Capacity	ml (oz.)	600 (20)
Fuel	type	Regular unleaded gasoline
Fuel Tank Capacity	l (qts.)	3.6 (3.8)
Valve Clearance (cold)	mm (in.)	Inlet: 0.085–0.115 (0.0033–0.0045) Outlet: 0.085–0.115 (0.0033–0.0045)

3.3 WP 1550V/VW

		WP 1550V/VW 0007577, 0007580
Plate		
Operating Weight	kg (lbs.)	91 (200)
Water Tank Capacity	l (qts.)	10.4 (11.0)
Exciter Speed	rpm / belt	5800
Exciter Lubrication	ml (oz.)	150 (5) Automatic Transmission Fluid Dextron III / Mercon or equivalent
Dimensions	mm (in.)	686 (27) x 508 (62) x 965 (38)

		WP 1550V/VW 0007577, 0007580
Engine		
Engine Make		Vanguard
Engine Model		115432-0047
Rated Power	kW (Hp)	4.5 (6.0)
Engine Speed - full	rpm	3600 ± 100
Engine Speed - idle	rpm	1400 ± 100
Clutch Engagement	rpm	2100
Spark Plug	type	Champion 12VC
Electrode Gap	mm (in)	0.76 (0.030)
Air Cleaner	type	Dual Element
Engine Lubrication	oil grade	SAE 10W30
	service class	SG, SF or SE
Engine Oil Capacity	ml (oz.)	600 (20)
Fuel	type	Regular unleaded gasoline
Fuel Tank Capacity	l (qts.)	4.0 (4.2)
Valve Clearance (cold)	mm (in.)	Inlet: 0.05–0.08 (0.002–0.003) Outlet: 0.05–0.08 (0.002–0.003)

3.4 WP 1540A/AW

		WP 1540A/AW 0008060, 0008061, 0009472
Plate		
Operating Weight	kg (lbs.)	86 (190)
Water Tank Capacity	l (qts.)	10.4 (11.0)
Exciter Speed	rpm / belt	5800
Exciter Lubrication	ml (oz.)	150 (5) Automatic Transmission Fluid Dextron III / Mercon or equivalent
Dimensions	mm (in.)	686 (27) x 400 (16) x 965 (38)

		WP 1540A/AW 0008060, 0008061, 0009472
Engine		
Engine Make		Honda
Engine Model		GX 160 K1 QX2
Rated Power	kW (Hp)	4.1 (5.5)
Engine Speed - full	rpm	3600 ± 100
Engine Speed - idle	rpm	1600 ± 100
Clutch Engagement	rpm	2100
Spark Plug	type	NGK BPR 6ES
Electrode Gap	mm (in)	0.7–0.8 (0.028–0.031)
Air Cleaner	type	Dual Element
Engine Lubrication	oil grade	SAE 10W30
	service class	SG or SF
Engine Oil Capacity	ml (oz.)	600 (20)
Fuel	type	Regular unleaded gasoline
Fuel Tank Capacity	l (qts.)	3.7 (3.9)
Valve Clearance (cold)	mm (in.)	Inlet: 0.15 (0.006) Outlet: 0.20 (0.008)

3.5 WP 1550/W

		WP 1550, WP 1550 W 0009325, 0009324
Plate		
Operating Weight	kg (lbs.)	88 (194)
Water Tank Capacity	l (qts.)	10.4 (11.0)
Exciter Speed	rpm / belt	5800 ± 100
Exciter Lubrication	ml (oz.)	150 (5) Automatic Transmission Fluid Dextron III / Mercon or equivalent

		WP 1550, WP 1550 W 0009325, 0009324
Engine		
Engine Make		Wacker
Engine Model		WM170
Rated Power	kW (Hp)	4.5 (6.0)
Engine Speed - full	rpm	3600 ± 50
Engine Speed - idle	rpm	1400 ± 100
Clutch Engagement	rpm	2100
Spark Plug	type	NGK BR6HS, Champion RL86C
Electrode Gap	mm (in)	0.6–0.7 (0.024–0.028)
Air Cleaner	type	Dual Element
Engine Lubrication	oil grade service class	SAE 10W30 SE or higher
Engine Oil Capacity	ml (oz.)	600 (20)
Fuel	type	Regular unleaded gasoline
Fuel Tank Capacity	l (qts.)	3.6 (3.8)
Valve Clearance (cold)	mm (in.)	
Inlet:		0.07–0.13 (0.003–0.005)
Outlet:		0.17–0.23 (0.007–0.009)

3.6 WP 1540/W

		WP 1540, WP 1540 W 0009237, 0009236
Plate		
Operating Weight	kg (lbs.)	86 (190)
Water Tank Capacity	l (qts.)	10.4 (11.0)
Exciter Speed	rpm / belt	5800
Exciter Lubrication	ml (oz.)	150 (5) Automatic Transmission Fluid Dextron III / Mercon or equivalent
Dimensions	mm (in.)	686 (27) x 400 (16) x 965 (38)

		WP 1540, WP 1540 W 0009327, 0009326
Engine		
Engine Make		Wacker
Engine Model		WM170
Rated Power	kW (Hp)	4.5 (6.0)
Engine Speed - full	rpm	3600 ± 50
Engine Speed - idle	rpm	1400 ± 100
Clutch Engagement	rpm	2100
Spark Plug	type	NGK BR6HS, Champion RL86C
Electrode Gap	mm (in)	0.6–0.7 (0.024–0.028)
Air Cleaner	type	Dual Element
Engine Lubrication	oil grade service class	SAE 10W30 SE or higher
Engine Oil Capacity	ml (oz.)	600 (20)
Fuel	type	Regular unleaded gasoline
Fuel Tank Capacity	l (qts.)	3.6 (3.8)
Valve Clearance (cold)	mm (in.)	
Inlet:		0.07–0.13 (0.003–0.005)
Outlet:		0.17–0.23 (0.007–0.009)

4. General

4.1 Application

This plate is designed for compacting loose, granular soils, gravel, and paving stones. It is intended to be used in confined areas and areas next to structures such as walls, curbs, and foundations. Plates equipped with water tanks can be used for compacting asphalt.

This plate is not recommended for compacting cohesive soils with a heavy clay content. For cohesive soil, use a vibratory rammer or sheepsfoot roller.

4.2 General Description

For the WP product line of vibroplates, engine power is transferred to the exciter through a centrifugal clutch and V-belt. The splash-lubricated exciter consists of an eccentric weighted, one-piece shaft that is supported on two roller bearings. The shaft assembly is mounted in an aluminum housing. The exciter vibrates at 6000 times per minute and produces approximately 15 kN (3375 pounds) of centrifugal force.

4.3 Periodic Maintenance Schedule

	Daily before starting	After first 20 hrs.	Every 2 weeks or 50 hrs.	Every month or 100 hrs.	Every year or 300 hrs.
Check fuel level.	•				
Check engine oil level.	•				
Inspect fuel lines.	•				
Inspect air filter. Replace as needed.	•				
Check and tighten external hardware.	•				
Check and adjust drive belt.		•	•		
Clean air cleaner elements.			•		
Inspect shockmounts for damage.			•		
Change engine oil.		•		•	
Clean engine cooling fins.				•	
Clean sediment cup / fuel filter.				•	
Check and clean spark plug.				•	
Check and adjust valve clearance.					•
Change exciter oil.					•

5. Baseplate

5.1 Exploded View

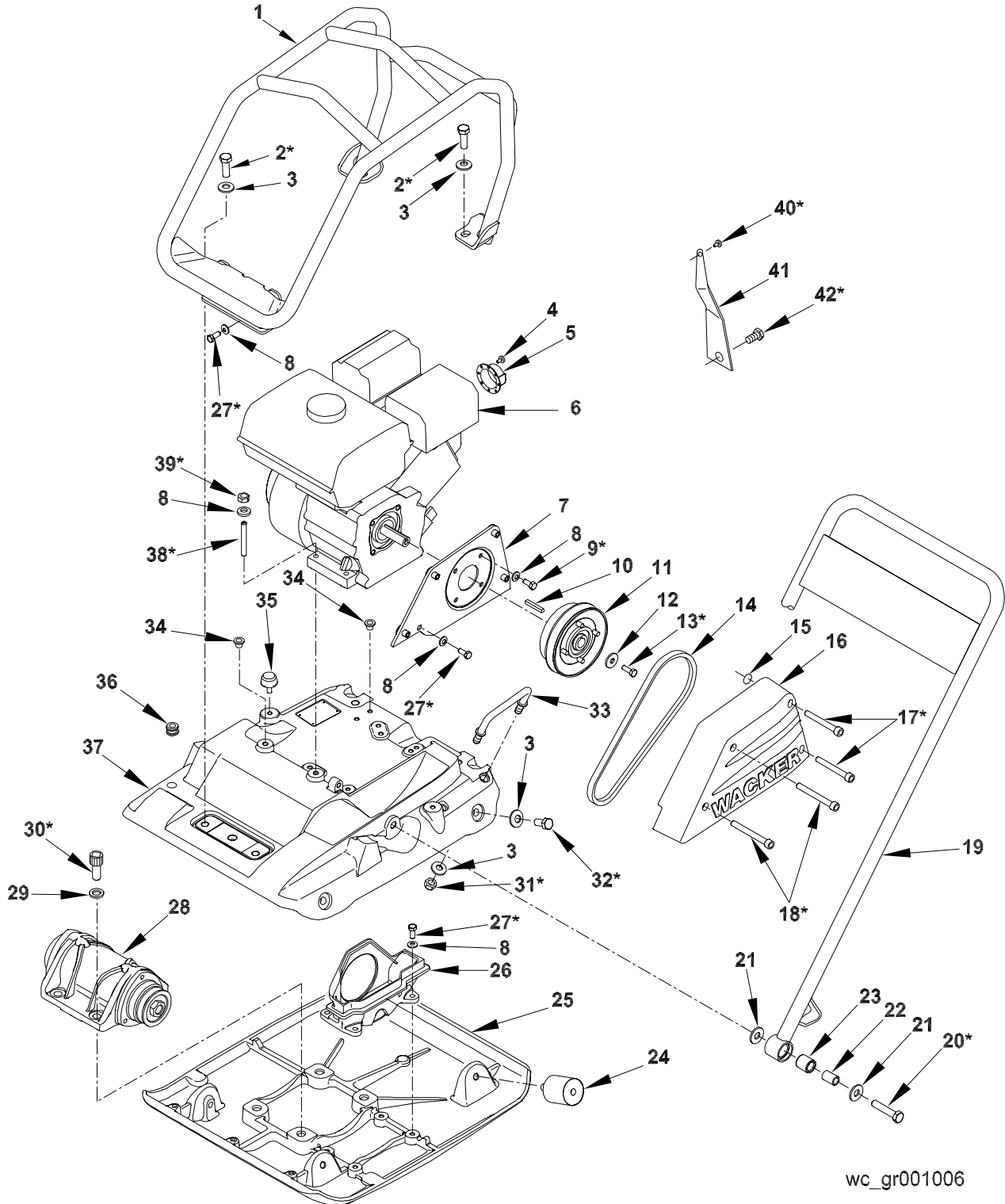

wc_gr001006

Parts List

Ref.	Description	Qty	Ref.	Description	Qty
1	Frame - lifting cage	1	22	Bushing - handle mount	2
2	Screw M12x35	4	23	Bushing - nylon	2
3	Washer - lock A12	12	24	Shockmount	4
4	Screw M4x6 (Honda only)	2	25	Baseplate	1
5	Baffle - exhaust (Honda only)	1	26	Beltguard - lower	1
6	Engine	1	27	Screw M8-20	7
7	Plate - beltguard	1	28	Exciter	1
8	Washer - lock B8	15	29	Washer	4
9	Screw 5/16-24x3/4	4	30	Screw M16x40	4
10	Key	1	31	Nut-lock M12	4
11	Clutch - adjustable	1	32	Screw M12x25	4
12	Washer - steel	1	33	Handle - lifting	2
13	Screw 5/16-24x7/8	1	34	Plug - Cap #1	6
14	Belt-V A27	1	35	Shockmount	2
15	O-Ring	4	36	Grommet	1
16	Beltguard - upper	1	37	Console	1
17	Screw M8x65	2	38	Stud M8x35	4
18	Screw M8x75	2	39	Nut-lock M8	4
19	Guide handle	4	40	Screw M6x12	1
20	Screw M12x60	2	41	Strap - muffler support	1
21	Washer - steel	4	42	Screw	1

Recommended Tools

Allen Wrench: 6 mm, 14 mm	Gear Puller
Socket: 1/2 in., 1-1/4 in., 13 mm, 19 mm	Torque Wrench
Open End Wrench: 13 mm, 19 mm	Arbor Press
Screwdriver	Oil: Automatic transmission fluid (Dextron III, Mercon or equivalent)

*** Assembly Notes**

Ref.	Sealant Loctite (Omnifit)	Torque Nm (ft.lbs.)	Ref.	Sealant Loctite (Omnifit)	Torque Nm (ft.lbs.)
2	---	73 (54)	30	271 (1550)	210 (155)
9	---	20 (15)	31	---	73 (54)
13	243 (1350)	20 (15)	32	---	73 (54)
17	---	20 (15)	38	243 (1350)	---
18	---	20 (15)	39	---	20 (15)
20		73 (54)	40	---	4.5 (40**)
27	243 (1350)	20 (15)	42	---	10.2 (90**)

** in.lbs.

5.2 Guide Handle

See Graphic: *wc_gr001007*

Removal:

- 5.2.1 Remove M12 screws **(20)** on each side of machine and remove guide handle assembly **(19)**.
- 5.2.2 Remove washers **(21)** and bushings **(22 and 23)** from handle. Press bushings from handle if necessary.
- 5.2.3 Replace shockmounts **(35)** if they appear cracked or damaged. Use a channel-lock pliers to unscrew shockmounts from console **(37)**.

Installation:

- 5.2.1 Install shockmounts **(35)** on console.
- 5.2.2 Install handle on console using washers **(21)**, bushings **(22 and 23)** and screws **(20)**. Tighten screws to 73 Nm (54 ft.lbs.).

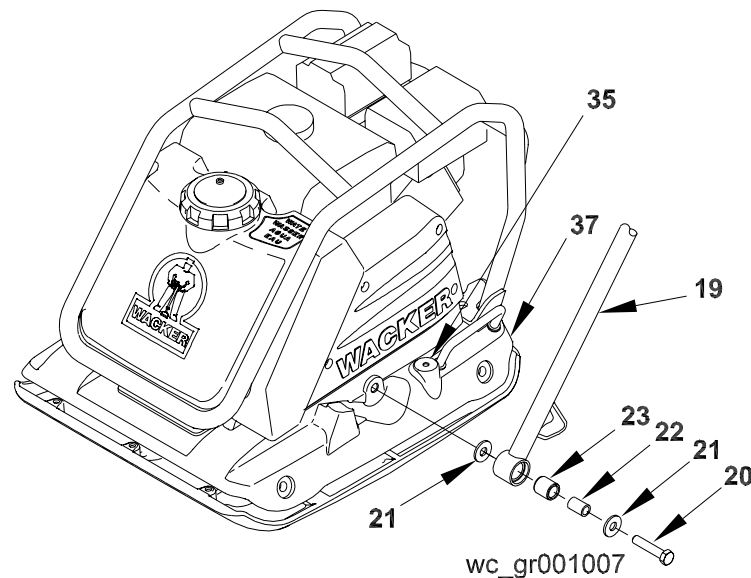

5.3 Frame-Lifting Cage

See Graphic: *wc_gr001008*

Removal:

- 5.3.1 For machines equipped with a water system, disconnect hose from water tank. Remove two screws and washers at the rear of the water tank.
- 5.3.2 Remove four screws **(2)** and washers **(3)**.
- 5.3.3 Lift frame assembly **(1)** from machine.
- 5.3.4 For machines equipped with a water system, remove two screws **(27)** and washers **(8)** to remove water tank from lifting cage.

Installation:

- 5.3.1 For water system machines, install water tank, washers **(8)** and screws **(27)**. Tighten screws to 20 Nm (15 ft.lbs.).
- 5.3.2 Install frame assembly **(1)**, washers **(3)** and screws **(2)**. Tighten screws to 73 Nm (54 ft.lbs.).
- 5.3.3 For water system machines, install two screws and washers at rear of tank. Tighten screws to 8.1 Nm (6 ft.lbs.).
- 5.3.4 Connect hose to water tank.

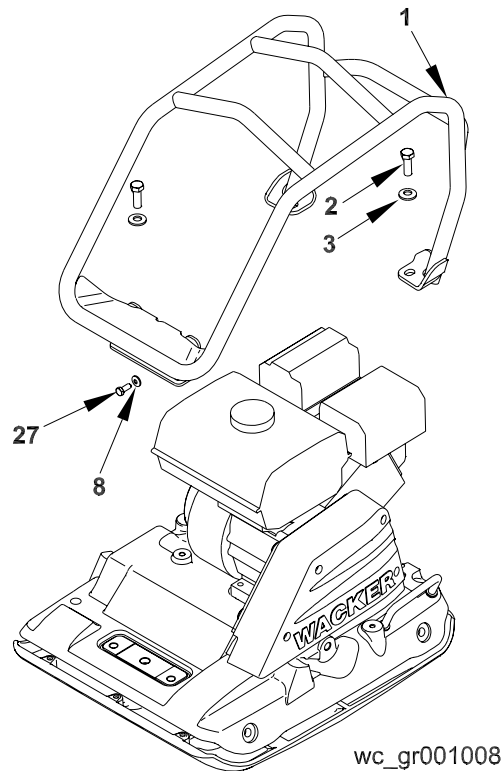

wc_gr001008

5.4 Drive Belt

See Graphic: *wc_gr001009*

Removal:

- 5.4.1 Pivot guide handle forward.
- 5.4.2 Remove screws **(17 and 18)** to remove beltguard **(16)**. O-rings **(15)** will remain on screws, and keep screws captive in the belt guard.
- 5.4.3 Remove four nuts **(a)** and lock washers holding pulley halves **(b)** and spacers **(c)** together.
- 5.4.4 Remove outer pulley half to remove drive belt from exciter pulley and machine.

Installation:

- 5.4.1 Install belt on exciter pulley.
- 5.4.2 Install three spacers **(c)** and outer pulley half with belt between pulley halves **(b)**.
- 5.4.3 Install lock washers and nuts **(a)**. Tighten nuts securely.
- 5.4.4 Pivot guide handle rearward to operating position.

Adjustment:

After the first 20 hours of use, check belt deflection. Drive belt deflection should be 6–9 mm (1/4 to 3/8 in.) half way between the clutch pulley and the exciter pulley.

Two or three spacers with new factory belts should provide the correct tension.

To increase belt tension (reduce amount of deflection):

- 5.4.1 Remove nuts **(a)** and lock washers. Remove outer pulley half and one spacer.
- 5.4.2 Install outer pulley half, then the unused spacer. Secure with lock washers and nuts **(a)**.
- 5.4.3 Check belt deflection again. If necessary, remove another spacer from between pulley halves and put outside of pulley halves.
- 5.4.4 Install belt guard **(16)**, O-rings **(15)** and screws **(17 and 18)**. Tighten screws to 20 Nm (15 ft.lbs.).

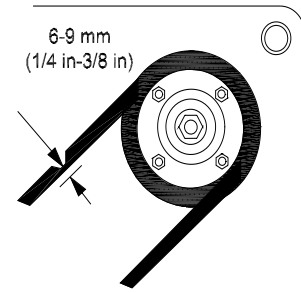
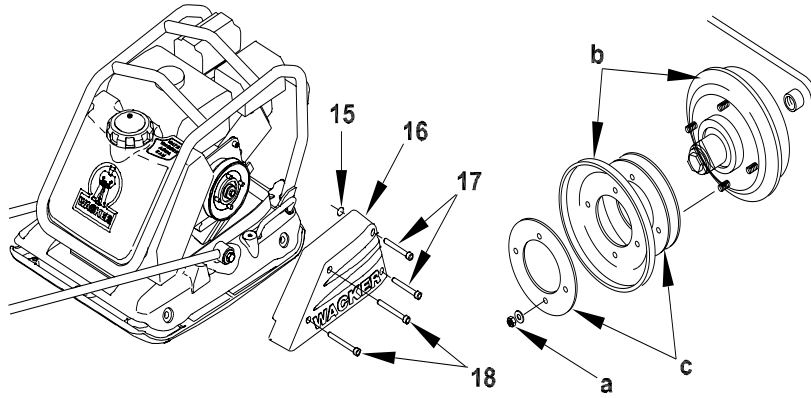

wc_gr001009

5.5 Engine

See Graphic: *wc_gr001010*

Removal:

- 5.5.1 Remove lifting cage frame as shown in Section *Frame - Lifting Cage*.
- 5.5.2 Remove drive belt as described in Section *Drive Belt*.
- 5.5.3 Remove screw (27) and washer (8).
- 5.5.4 Remove four M8 lock nuts (39) and washers (8).
- 5.5.5 Carefully lift the engine (6) from the console.
- 5.5.6 If necessary, remove clutch from engine as described in Section *Clutch*.

Installation:

- 5.5.1 If removed, install clutch on engine as described in Section *Clutch*.
- 5.5.2 If removed, apply Loctite 242 or equivalent to lower threads of M8x35 studs (38) and install in console securely.

Note: For Honda and Robin engines, use the inner 4-hole pattern. For Vanguard engines, use outer hole pattern at the rear and inner hole pattern at the front of the machine.

- 5.5.3 Install engine (6), four washers (8) and four lock nuts (39). Tighten lock nuts to 20 Nm (15 ft.lbs.).
- 5.5.4 Install washer (8) and screw (27) in beltguard plate. Tighten screw to 20 Nm (15 ft.lbs.).
- 5.5.5 Install drive belt and beltguard as described in Section *Drive Belt*.
- 5.5.6 Install lifting cage frame as shown in Section *Frame - Lifting Cage*.

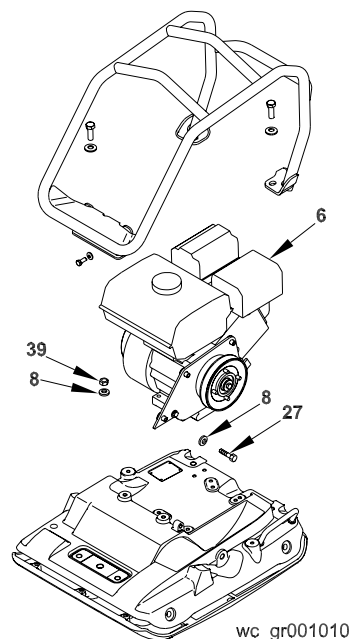

6. Exciter

6.1 Exciter Exploded View

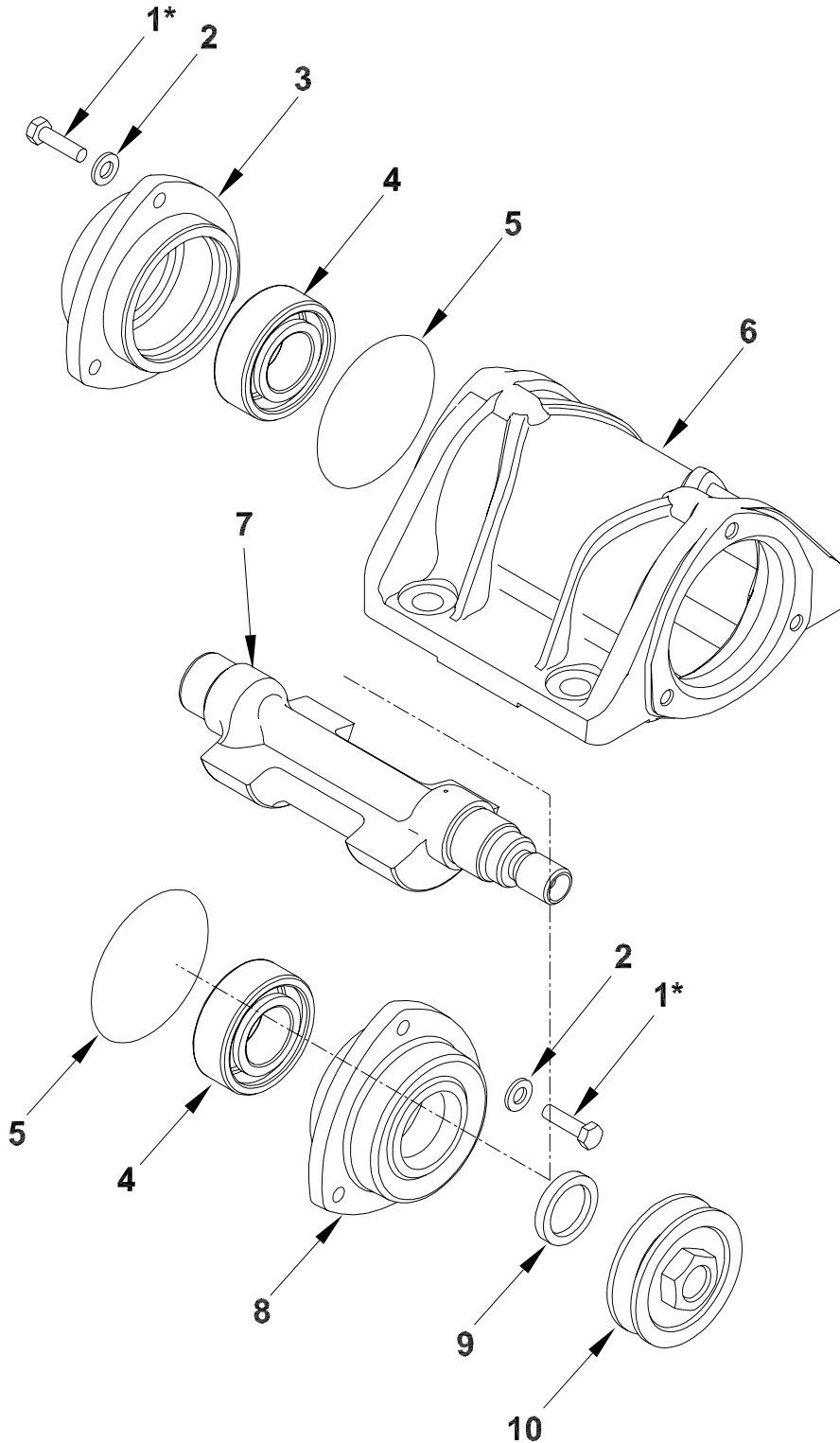

wc_gr001011

Parts List

Ref.	Description	Qty	Ref.	Description	Qty
1	Screw M8x30	6	6	Housing - exciter	1
2	Washer - lock B8	6	7	Shaft - exciter	1
3	Holder - bearing w/o hole	1	8	Holder - bearing w/ hole	1
4	Bearing - roller	2	9	Seal - shaft	1
5	O-Ring	2	10	Pulley - exciter	1

Recommended Tools

Allen Wrench: 14 mm

Socket: 13 mm

Open End Wrench: 1-1/4 in.

Screwdriver

Bearing Puller

Torque Wrench

Bearing and Seal Driver Set

Arbor Press

Hammer

Blunt End Punch

Oil: Automatic transmission fluid
(Dextron III, Mercon or equivalent)

Ref.	Sealant Loctite (Omnifit)	Torque Nm (ft.lbs.)
1	---	30 (22)

6.2 Lower Belt Guard

See Graphic: *wc_gr001012*

Removal:

- 6.2.1 Remove drive belt as described in Section *Drive Belt*.
- 6.2.2 For machines equipped with a water system, disconnect hose from water tank.
- 6.2.3 Remove four screws **(a)** securing console assembly to baseplate and lift console assembly from baseplate.
- 6.2.4 Remove four screws **(b)** and washers.
- 6.2.5 Remove belt guard **(c)** from baseplate.

Installation:

- 6.2.1 Install belt guard **(c)** to baseplate.
- Note: Install washers with concave side towards machine.**
- 6.2.2 Apply Loctite 243 or equivalent to threads of four M8 screws **(b)** and to screw holes. Install four conical washers and screws **(b)**. Tighten screws to 20 Nm (15 ft.lbs.).
 - 6.2.3 Lift console assembly onto baseplate. Install washers and M12 screws **(a)**. Tighten screws to 73 Nm (54 ft.lbs.).
- Note: Install washers with concave side towards console.**
- 6.2.4 For machines equipped with a water system, connect hose to the water tank.
 - 6.2.5 Install drive belt and belt guard as described in Section *Drive Belt*.

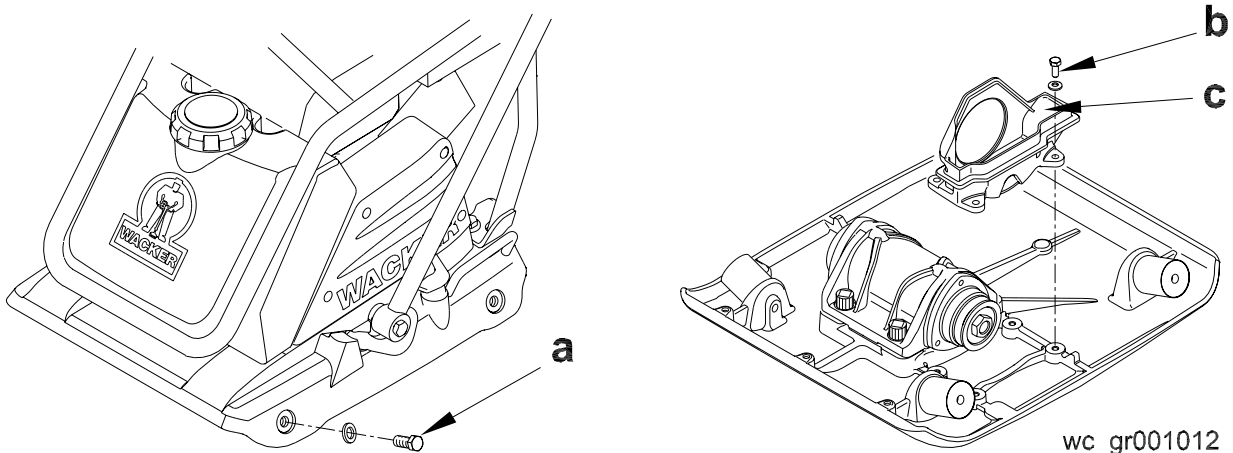

6.3 Exciter

See Graphic: *wc_gr001013*

Removal:

Note: Removing the exciter housing from the baseplate should only be done in the event that the exciter housing is damaged. Routine maintenance to the exciter should not require removal of the exciter housing from the baseplate.

- 6.3.1 Remove drive belt as described in Section *Drive Belt*.
 - 6.3.2 For machines equipped with a water system, disconnect hose from water tank.
 - 6.3.3 Remove four screws **(a)** securing console assembly to baseplate and lift console assembly from baseplate.
- Note:** A heat source will be necessary to loosen Loctite on screws **(b)**.
- 6.3.4 Remove four screws **(b)** and washers.
 - 6.3.5 Remove exciter **(c)** from baseplate.

Installation:

- 6.3.1 Install exciter **(c)** to baseplate.
 - 6.3.2 Clean and apply Loctite 271 or equivalent to threads of M16 screws **(b)**. Install four washers and screws **(b)**. Tighten screws to 210 Nm (155 ft.lbs.).
- Note:** Install washers with concave side towards console.
- 6.3.3 Lift console assembly onto baseplate. Install washers and M12 screws **(a)**. Tighten screws to 73 Nm (54 ft.lbs.).
 - 6.3.4 For machines equipped with a water system, connect hose to the water tank.
 - 6.3.5 Install drive belt and beltguard as described in Section *Drive Belt*.

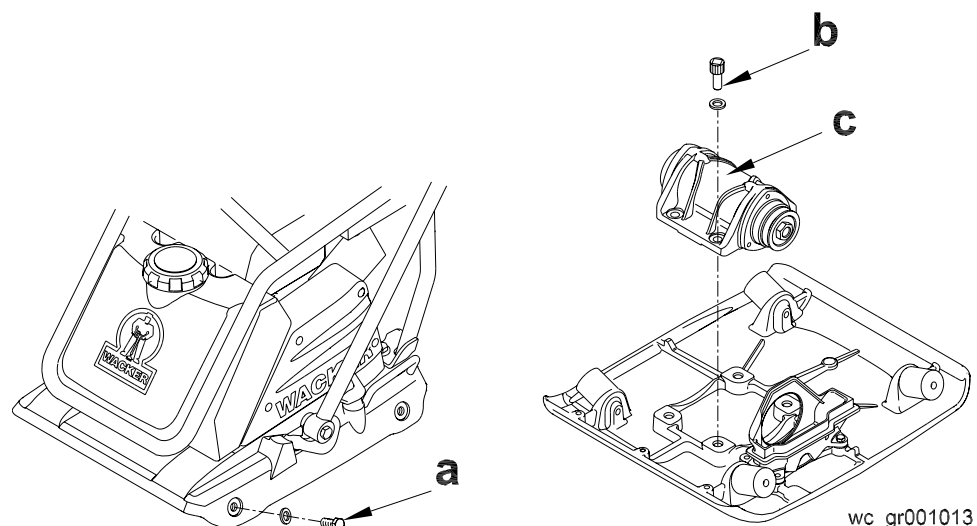

6.4 Exciter Components

See Graphic: *wc_gr001014*

Disassembly:

6.4.1 If the exciter housing is damaged, remove the exciter as described in Section *Exciter*.

Note: *Pulley threads are left hand threads.*

6.4.2 Remove the exciter pulley (12) using a 1-1/4 in. socket.

Note: *If pulley does not loosen from shaft at this point, remove shaft assembly from housing and then remove pulley.*

CAUTION: Exciter shaft is not retained at pulley end, shaft can fall from housing when bearing holder is removed.

6.4.3 Remove three M8 screws (1) and washers (2) securing bearing holder (3) and drain oil into pan.

6.4.4 Remove exciter shaft (9) with inner roller bearing races (d).

6.4.5 Remove three M8 screws (1) and washers (2) securing shaft-end bearing holder (10) and remove holder.

6.4.6 Remove seal (11) from shaft-end bearing holder.

Note: *Keep outer and inner bearing races together as matched sets and replace them as sets.*

6.4.7 Remove roller bearings outer races (e) and O-rings (5) from bearing holders (3 and 10) using bearing puller tool.

6.4.8 Remove bearing inner races (d) using a bearing puller tool.

Note: *It is only necessary to remove inner races if bearing is to be replaced. Heat inner races to aid removal. If bearing is not being replaced, be sure to match inner races with mating outer races during assembly.*

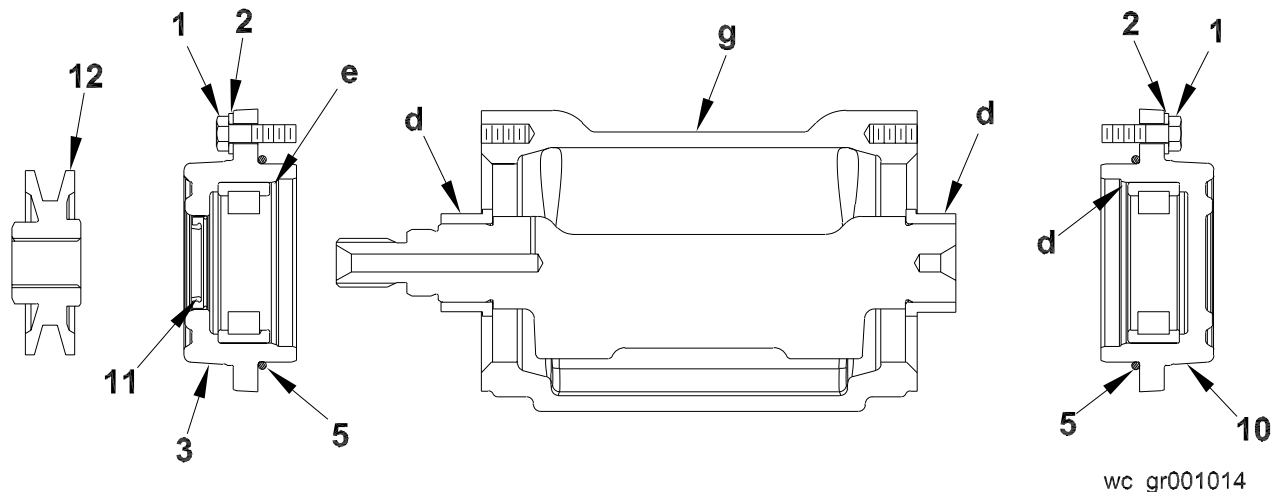

See Graphic: *wc_gr001028*

Assembly:

- 6.4.1 Clean the inside of the exciter housing and bearing housings thoroughly. Make sure vent passage **(a)** in shaft is free of any obstruction.
- 6.4.2 If replacing bearings, use an appropriate size and length of pipe to press new inner races **(b)** onto exciter shaft as shown.
- Note:** *Keep outer and inner bearing races together as a set.*
- 6.4.3 Apply automatic transmission fluid to outer bearing races **(c)**. Use an appropriate size disk from bearing and seal driver set to press outer bearing races **(c)** into bearing holders **(3 and 10)**.
- 6.4.4 Install seal in bearing holder **(3)** approximately 2.5 mm (0.1 in.) below top of bore.
- Note:** *Lips of seal should be towards roller bearing.*
- 6.4.5 Apply petroleum jelly to O-rings **(5)** and seal lips. Install O-rings on bearing holders.
- 6.4.6 Apply Loctite 243 or equivalent to threads of three M8 screws **(1)** and to screw holes. Install bearing holder **(10)** without hole using screws **(1)** and washers **(2)**. Tighten screws to 30 Nm (22 ft.lbs.).
- 6.4.7 Put the exciter assembly in a vertical position and install exciter shaft **(9)** into case.
- 6.4.8 Fill exciter with oil, before operating. See *Technical Data* for oil quantity and type.
- 6.4.9 Apply Loctite 243 or equivalent to threads of remaining three M8 screws **(1)** and to screw holes. Install bearing holder **(3)** with hole using screws **(1)** and washers **(2)**. Use care not to damage seal lips. Tighten screws to 30 Nm (22 ft.lbs.).
- 6.4.10 Install exciter pulley onto shaft.
- Note:** *Threads are left handed.*
- 6.4.11 Install exciter assembly to loose frame as described in Section *Exciter*.

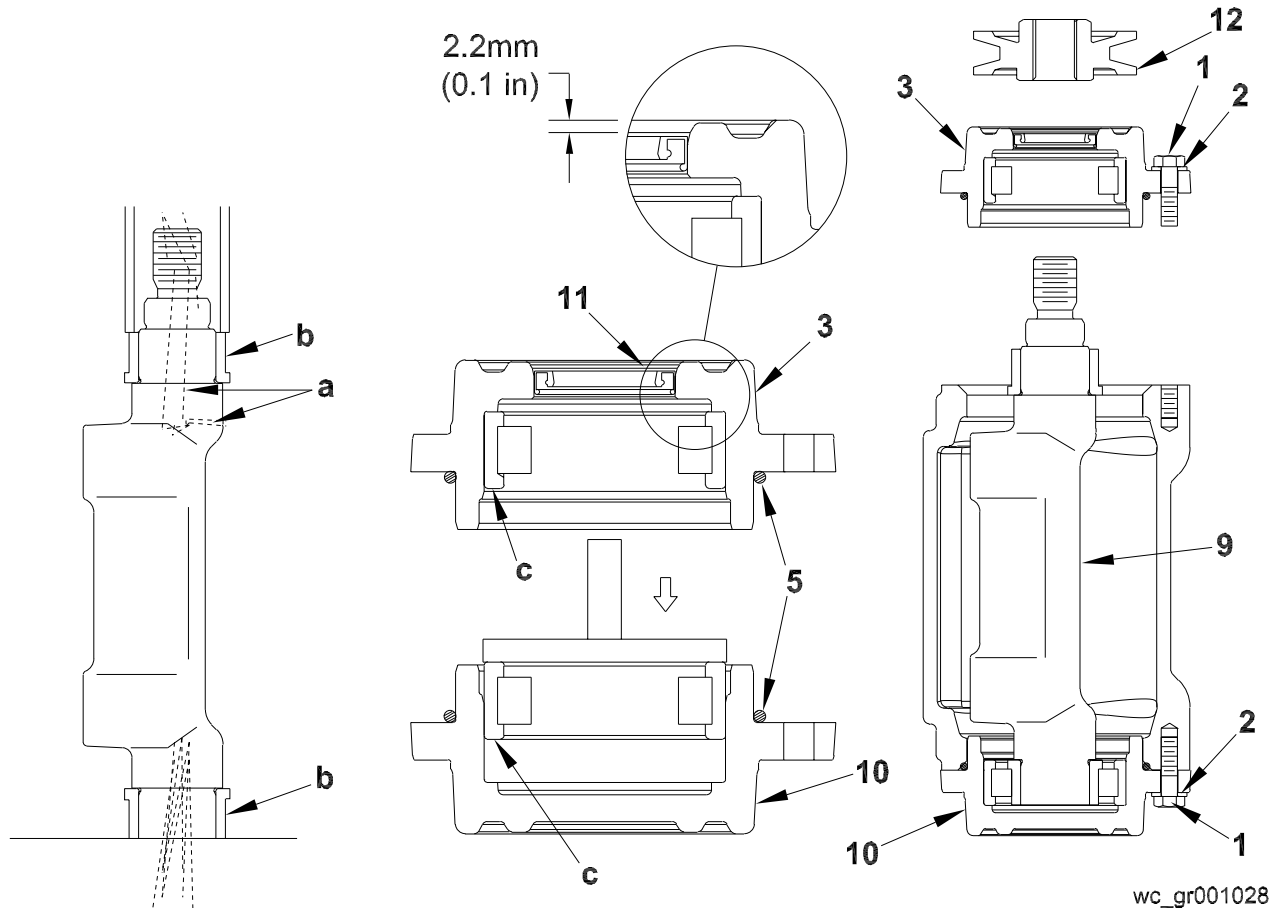

7. Clutch

7.1 Clutch Assembly Exploded View

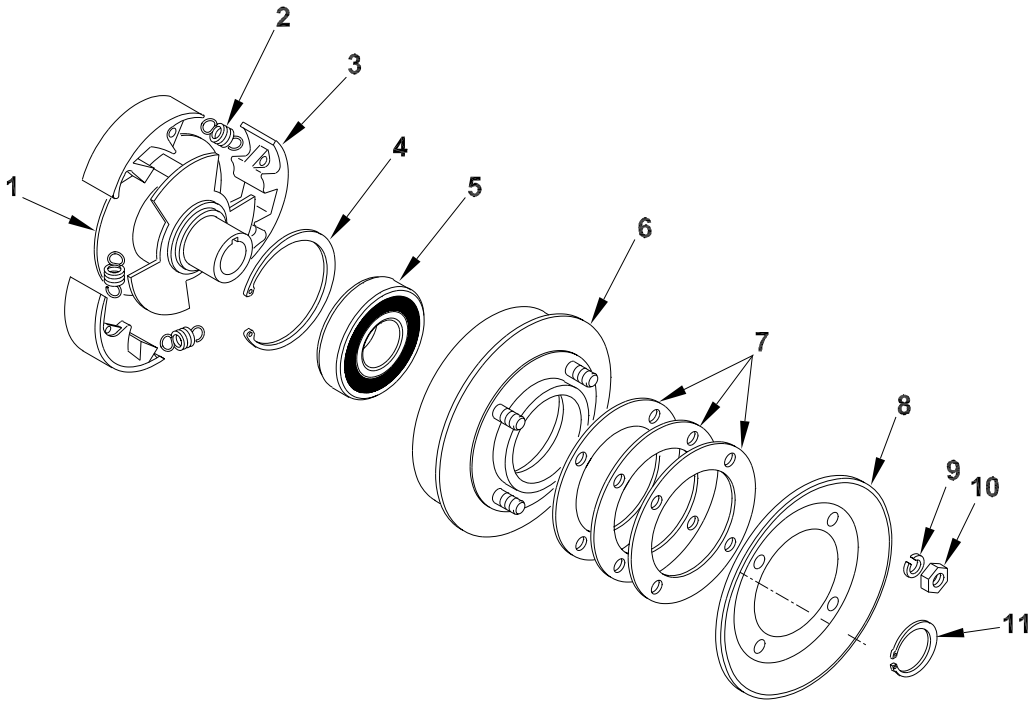

wc_gr001015

Parts List

Ref.	Description	Qty	Ref.	Description	Qty
1	Clutch hub	1	7	Spacer - clutch	3
2	Spring - clutch	3	8	Pulley - clutch	1
3	Shoe - clutch	3	9	Washer - lock	4
4	Retaining ring	1	10	Nut - hex	4
5	Bearing - ball	1	11	Retaining ring	1
6	Clutch drum	1			

Recommended Tools

Internal Retaining Ring Pliers
 External Retaining Ring Pliers
 Arbor Press
 Tachometer

Open End Wrench: 13 mm
 Pliers
 Anti-seize
 Two Pry Bars

7.2 Clutch

See Graphic: *wc_gr001016*

Removal:

- 7.2.1 Remove drive belt as described in Section *Drive Belt*.
- 7.2.2 Remove screw **(a)** and washer securing clutch **(b)** to engine shaft. Pry clutch from engine shaft using two pry bars. Use care not to damage clutch while prying.
- 7.2.3 Remove key **(c)**.
- 7.2.4 If necessary, remove four screws **(d)** and washers and screw **(e)** and washer to remove beltguard plate **(f)**.

Installation:

- 7.2.1 If removed, install beltguard plate **(f)** using washers and screws **(d and e)**. Tighten screws to 20 Nm (15 ft.lbs.).
- 7.2.2 Install key **(c)** on engine shaft. Apply anti-seize compound to shaft.
- 7.2.3 Apply Loctite 242 to threads of screw **(a)**. Secure clutch assembly **(b)** to engine shaft using washer and screw **(a)**. Tighten screw to 20 Nm (15 ft.lbs.).
- 7.2.4 Install drive belt and beltguard as described in Section *Drive Belt*.

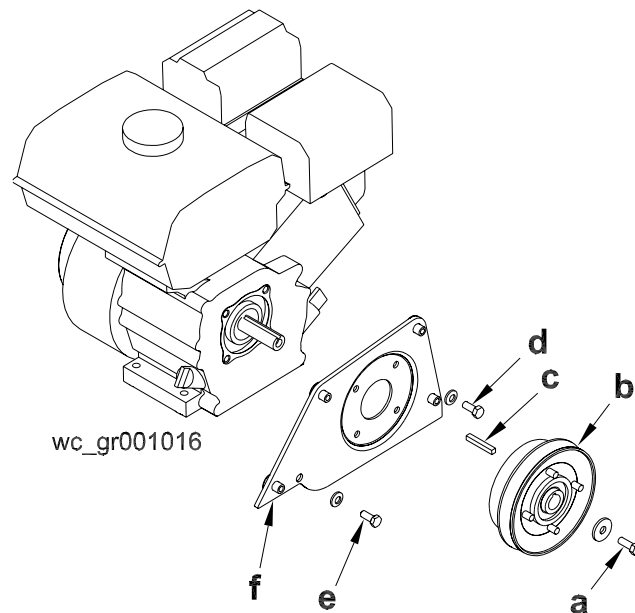

7.3 Clutch Components

See Graphic: *wc_gr001017*

Disassembly:

- 7.3.1 Remove clutch as described in Section *Clutch*.
- 7.3.2 Remove retaining ring **(11)**.
- 7.3.3 Support clutch drum assembly on edge as shown **(a)** and press out clutch hub assembly.
- 7.3.4 Remove bearing retaining ring **(4)**.
- 7.3.5 Support clutch drum **(6)** and press out bearing **(5)**.
- 7.3.6 Remove springs **(2)** with pliers to remove shoes **(3)** from hub **(1)**.

Assembly:

- 7.3.1 Press new bearing **(5)** into clutch drum **(6)**. Secure bearing with retaining ring **(4)**.
- 7.3.2 Assemble shoes **(3)** and springs **(2)** on clutch hub **(1)**. Press assembly into clutch drum and secure with retaining ring **(11)**.
- 7.3.3 Install clutch on engine shaft as described in Section *Clutch*.

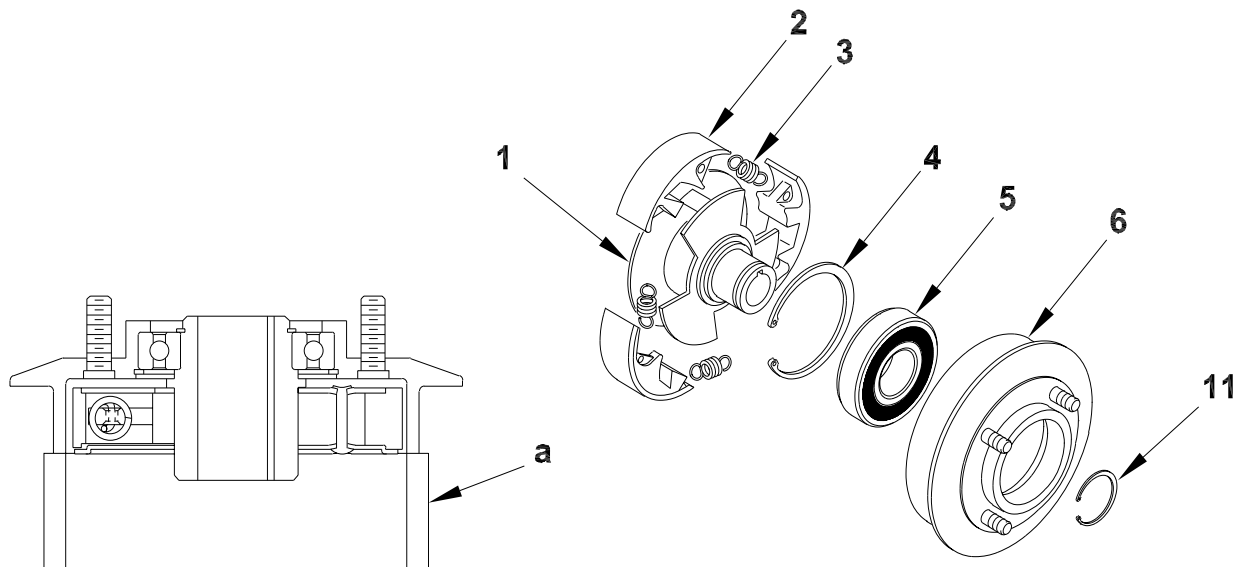

wc_gr001017

7.4 Clutch Engagement Speed Test



Take care when testing machine with beltguard removed to avoid loose clothing, jewelery, long hair, etc., from getting caught in rotating parts. Replace beltguard after testing and before operating machine.

- 7.4.1 Remove beltguard as described in Section *Drive Belt*.
- 7.4.2 Put machine on a rubber test mat to prevent it from moving.
- 7.4.3 Start engine and allow it to warm up.
- 7.4.4 Pull throttle to full speed. Allow the exciter to reach full speed for a few seconds, then return to idle.
- 7.4.5 Attach tachometer and slowly increase engine speed. Note the engine speed reading when clutch pulley starts to rotate. Correct clutch speed is 2100 ± 100 RPM.
- 7.4.6 If clutch engagement is below 2000 RPM, check for weak springs. If clutch engagement is over 2200 RPM, clutch may be worn and require replacement, or exciter belt may be binding.

8. Water System

8.1 Water System Exploded View

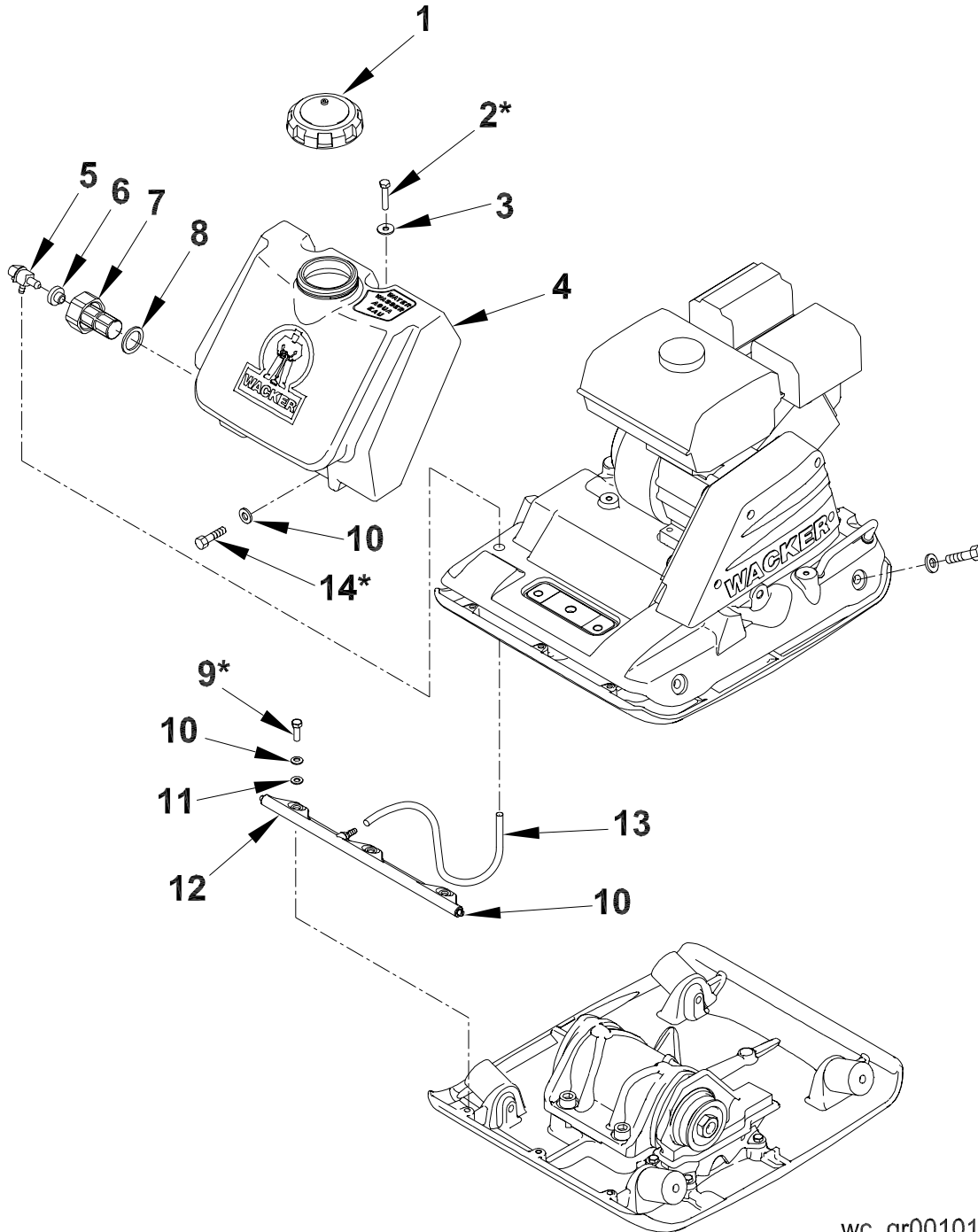

wc_gr001018

Parts List

Ref.	Description	Qty	Ref.	Description	Qty
1	Cap-water tank	1	9	Screw M8 x 25	3
2	Screw M8 x 40	2	10	Washer-lock B8	4
3	Washer B8.4	2	11	Washer B8.4	3
4	Tank-water	1	12	Manifold-water tank	1
5	Valve-shutoff	1	13	Hose	1
6	Bushing-tank valve	1	14	Screw M8 x 20	2
7	Filter-water	1	15	Plug 1/4-18 NPT	2
8	Seal-ring	1			

Recommended Tools

Socket: 13 mm, 19 mm

Pliers

Wrench: 13 mm

*** Assembly Notes**

Ref.	Sealant Loctite (Omnifit)	Torque Nm (ft.lbs.)	Ref.	Sealant Loctite (Omnifit)	Torque Nm (ft.lbs.)
2	---	8.1 (6)	14	---	20 (15)
9	243 (1350)	20 (15)			

9. Troubleshooting

Problem / Symptom	Reason / Remedy
<p>Plate does not develop full speed. Poor compaction.</p>	<ul style="list-style-type: none"> • Engine throttle control not completely open. • Throttle control not adjusted correctly. • Ground too wet, plate sticking. Allow soil to dry before compacting. • Drive belt loose or worn, slipping on pulleys. Adjust or replace belt. Check that engine mounting bolts are tight. • Exciter bearings binding. Check condition and level of oil in exciter. Add or change oil. • Air filter clogged with dust, reducing engine performance. Clean or replace air filter. • Engine speed too low. Check engine speed with tachometer. Adjust or repair engine to run at correct speed. Refer to engine manual.
<p>Engine running, no vibration</p>	<ul style="list-style-type: none"> • Engine throttle not open. • Drive belt loose or broken. Adjust or replace. • Clutch damaged. Inspect and replace clutch. • Engine speed too low. Check engine speed. • Too much oil in exciter. Adjust oil to correct level.
<p>Plate jumps or compacts unevenly.</p>	<ul style="list-style-type: none"> • Ground surface too hard. • Shockmounts loose or damaged.

Notes:

Threadlockers and Sealants

Threadlockers and Sealants

Threadlocking adhesives and sealants are specified throughout this manual by a notation of "S" plus a number (S#) and should be used where indicated. Threadlocking compounds normally break down at temperatures above 175°C (350°F). If a screw or bolt is hard to remove, heat it using a small propane torch to break down the sealant. When applying sealants, follow instructions on container. The sealants listed below are recommended for use on Wacker equipment.



TYPE () = Europe	COLOR	USAGE	PART NO. - SIZE
Loctite 222 Hernon 420 Omnifit 1150 (50M)	Purple	Low strength, for locking threads smaller than 6 mm (1/4"). Hand tool removable. Temp. range, -54 to 149°C (-65 to 300°F)	73287 - 10 ml
Hernon 423 Omnifit 1350 (100M)	Blue	Medium strength, for locking threads larger than 6 mm (1/4"). Hand tool removable. Temp. range, -54 to 149°C (-65 to 300°F)	29311 - .5 ml 17380 - 50 ml
Loctite 271/277 Hernon 427 Omnifit 1550 (220M)	Red	High strength, for all threads up to 25 mm (1"). Heat parts before disassembly. Temp. range, -54 to 149°C (-65 to 300°F)	29312 - .5 ml 26685 - 10 ml 73285 - 50 ml
Loctite 290 Hernon 431 Omnifit 1710 (230LL)	Green	Medium to high strength, for locking preassembled threads and for sealing weld porosity (wicking). Gaps up to 0.13 mm (0.005") Temp. range, -54 to 149°C (-65 to 300° F)	28824 - .5 ml 25316 - 10 ml
Loctite 609 Hernon 822 Omnifit 1730 (230L)	Green	Medium strength retaining compound for slip or press fit of shafts, bearings, gears, pulleys, etc. Gaps up to 0.13 mm (0.005") Temp. range, -54 to 149°C (-65 to 300°F)	29314 - .5 ml
Loctite 545 Hernon 947 Omnifit 1150 (50M)	Brown	Hydraulic sealant Temp. range, -54 to 149°C (-65 to 300°F)	79356 - 50 ml
Loctite 592 Hernon 920 Omnifit 790	White	Pipe sealant with Teflon for moderate pressures. Temp. range, -54 to 149°C (-65 to 300°F)	26695 - 6 ml 73289 - 50 ml
Loctite 515 Hernon 910 Omnifit 10	Purple	Form-in-place gasket for flexible joints. Fills gaps up to 1.3 mm (0.05") Temp. range, -54 to 149°C (-65 to 300°F)	70735 - 50 ml
Loctite 496 Hernon 110 Omnifit Sicomet 7000	Clear	Instant adhesive for bonding rubber, metal and plastics; general purpose. For gaps up to 0.15 mm (0.006") Read caution instructions before using. Temp. range, -54 to 82°C (-65 to 180°F)	52676 - 1 oz.

Threadlockers and Sealants

TYPE () = Europe	COLOR	USAGE	PART NO. - SIZE
Loctite Primer T Heron Primer 10 Omnifit VC Activator	Aerosol Spray	Fast curing primer for threadlocking, retaining and sealing compounds. Must be used with stainless steel hardware. Recommended for use with gasket sealants.	2006124 - 6 oz.

Torque Values

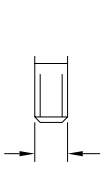
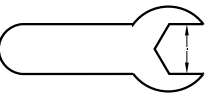
Metric Fasteners (DIN)

	TORQUE VALUES (Based on Bolt Size and Hardness)						WRENCH SIZE			
	8.8		10.9		12.9					
Size	ft.lb.	Nm	ft.lb.	Nm	ft.lb.	Nm	Inch	Metric	Inch	Metric
M3	*11	1.2	*14	1.6	*19	2.1	7/32	5.5	-	2.5
M4	*26	2.9	*36	4.1	*43	4.9	9/32	7	-	3
M5	*53	6.0	6	8.5	7	10	5/16	8	-	4
M6	7	10	10	14	13	17	-	10	-	5
M8	18	25	26	35	30	41	1/2	13	-	6
M10	36	49	51	69	61	83	11/16	17	-	8
M12	63	86	88	120	107	145	3/4	19	-	10
M14	99	135	140	190	169	230	7/8	22	-	12
M16	155	210	217	295	262	355	15/16	24	-	14
M18	214	290	298	405	357	485	1-1/16	27	-	14
M20	302	410	427	580	508	690	1-1/4	30	-	17



1 ft.lb. = 1.357 Nm.

* = in.lb.

1 Inch = 25.4 mm

Torque Values

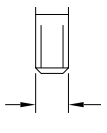
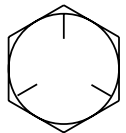
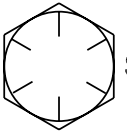
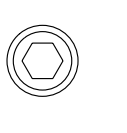
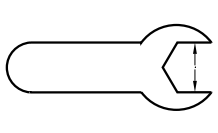
Inch Fasteners (SAE)

	 SAE 5		 SAE 8							
	ft.lb.	Nm	ft.lb.	Nm	ft.lb.	Nm	Inch	Metric	Inch	Metric
No.4	*6	0.7	*14	1.0	*12	1.4	1/4	5.5	3/32	-
No.6	*12	1.4	*17	1.9	*21	2.4	5/16	8	7/64	-
No.8	*22	2.5	*31	3.5	*42	4.7	11/32	9	9/64	-
No.10	*32	3.6	*45	5.1	*60	6.8	3/8	-	5/32	-
1/4	6	8.1	9	12	12	16	7/16	-	3/32	-
5/16	13	18	19	26	24	33	1/2	13	1/4	-
3/8	23	31	33	45	43	58	9/16	-	5/16	-
7/16	37	50	52	71	69	94	5/8	16	3/8	-
1/2	57	77	80	109	105	142	3/4	19	3/8	-
9/16	82	111	115	156	158	214	13/16	-	-	-
5/8	112	152	159	216	195	265	15/16	24	1/2	-
3/4	200	271	282	383	353	479	1-1/8	-	5/8	-

1 ft.lb. = 1.357 Nm.

* = in.lb.

1 Inch = 25.4 mm

