

www.wackergroup.com

0109984en	002
12.2006	

Vibratory plate

DPU 4045H

Operator's Manual

Important information

This machine has been provided with an EPA-certified engine.

Additional information can be found in the engine manufacturer's notes.

WARNING

Engine exhaust, some of its constituents, and certain vehicle components contain or emit chemicals known to the State of California to cause cancer and birth defects or other reproductive harm.

Caution

This engine is an EPA engine.
Adjusting the engine speed will interfere with EPA certification and the emissions.
Only authorized personnel can make adjustments to this engine.
Please contact your nearest engine dealer or your Wacker Dealer for more information.



1. Foreword

For your own safety and protection from bodily injuries, carefully read, understand and follow the safety instructions in this manual.

Please operate and maintain your Wacker machine in accordance with the instructions in this manual. Your Wacker machine will reward your attention by giving trouble-free operation and a high degree of availability.

Replace faulty or defective components immediately.

All rights, especially the right for copying and distribution are reserved

Copyright 2006 by Wacker Construction Equipment AG

No part of this publication may be reproduced in any form or by any means, electronic or mechanical, including photocopying, without express permission in writing from Wacker Construction Equipment AG.

Any type or manner of reproduction, distribution or storage on data carriers or storage mediums not authorized by Wacker represents an infringement of valid copyrights and will be prosecuted. We expressly reserve the right to make technical modifications - even without due notice - which aim at improving our machines or increasing their safety standards.

Table Of Contents

1. Foreword	3
2. Safety instruction	6
2.1 General instructions	6
2.2 Operation	6
2.3 Safety checks	8
2.4 Maintenance	9
2.5 Transport	9
2.6 Maintenance checks	10
3. Technical Data	11
4. Description	13
4.1 Applications	13
4.2 Dimensions	13
4.3 Max. admissible inclination	13
4.4 Description of function	14
5. Transport to work site /Recommendations on compaction	16
5.1 Transport to work site	16
5.2 Recommendations on compaction	17
6. Operation	18
6.1 Starting	18
6.2 Mechanical oil pressure control	20
6.3 Forward and reverse motion	21
6.4 Switching off	21
6.5 Compaction without extension plates	21
6.6 Additional notes on starting at very low temperatures!	22

Table Of Contents

7. Maintenance	23
7.1 Maintenance schedule	23
7.2 Engine oil	24
7.3 Hydraulic control	25
7.4 Exciter	26
7.5 Exciter V-belt	27
8. Faults	28
8.1 Forward speed too low	28
8.2 Reverse speed too low	28
8.3 No reverse motion	28
8.4 Loss of hydraulic oil	28
8.5 Engine does not start	29
9. Lables	30
EC - Conformity Certificate	31
DIN EN ISO 9001 Certificate	33

Safety instruction

2. Safety instruction

for the use of vibratory plates with combustion engines

2.1 General instructions

- 2.1.1 Vibratory plates may only be operated by persons who
- * are at least 18 years of age
 - * are physically and mentally fit for this job
 - * have been instructed in guiding vibratory plates and proved their ability for the job to the employer
 - * may be expected to carry out the job they are charged with carefully.
- The persons must be assigned the job of guiding vibratory plates by the employer.
- 2.1.2 Vibratory plates may only be used for compaction jobs. Both the manufacturer's operating instructions and these safety instructions have to be observed.
- 2.1.3 The persons charged with the operation of vibratory plates have to be made familiar with the necessary safety measures relating to the machine. In case of extraordinary uses the employer shall give the necessary additional instructions.
- 2.1.4 It is possible that these vibratory plates exceed the admissible assessment sound level of 89 dB (A). Employees must wear personal ear protection if the sound level reaches 89 dB (A) or more.

2.2 Operation

- 2.2.1 When starting the diesel engine with a starter crank make sure you have assumed a proper position with respect to the engine and that your hands are placed properly on the crank.



Only use the original engine manufacturer's safety starting crank.

To avoid a possible return kick, turn safety starting crank through with full force until the engine starts running.

- 2.2.2 The function of operation levers or elements is not to be influenced or rendered ineffective.

- 2.2.3 During operation the operator may not leave the control elements.
- 2.2.4 The operator has to stop the engine of the vibratory plate before going on breaks. The machine has to be placed such that it cannot turn over.
- 2.2.5 Stop engine before filling fuel tank. When refilling fuel tank, do not allow fuel to come into contact with the hot part of the engine or spill onto the ground.
- 2.2.6 Do not smoke or handle open fire near this machine.
- 2.2.7 The tank lid must fit tightly. Shut fuel cock if available when stopping the engine. For long distance transports of machines operated by fuel or fuel - mixtures, the fuel tank has to be drained completely.
Leaky fuel tanks may cause explosions and must therefore be replaced immediately.
- 
- 2.2.8 Do not operate this machine in areas where explosions may occur.
- 2.2.9 Make sure that sufficient fresh air is available when operating vibratory plates equipped with combustion engines in enclosed areas, tunnels, galleries and deep trenches.
- 2.2.10 During operation keep your hands, feet and clothes away from the moving parts of the vibraton plate. Wear safety shoes, and eye protection glasses in case of trench operation where falling sand stones maybe ejected.
- 2.2.11 When working near the edges of breaks, pits, slopes, trenches and platforms, vibratory plates are to be operated such that there is no danger of their turning over or dropping in.
- 2.2.12 Make sure the soil or subsoil to be compacted has a high enough load carrying capacity.
- 2.2.13 Use appropriate protective clothing while working or while carrying out maintenance work.

Safety instruction

- 2.2.14 When traveling backwards the operator has to guide the vibration plate laterally by its guide handle so that he will not be squeezed between the handle and a possible obstacle. Special care is required when working on uneven ground or when compacting coarse material. Make sure of a firm stand when operating the machine under such conditions.
- 2.2.15 Vibratory plates are to be guided such that hand injuries caused by solid objects are avoided.
- 2.2.16 Vibratory plates have to be guided such that their stability is guaranteed.
- 2.2.17 Machines with integrated transport trolley may not be parked or stored on the trolley. This device has only been designed to transport the machine.

2.3 Safety checks

- 2.3.1 Vibratory plates may only be operated with all safety devices installed.
- 2.3.2 Before starting operation, the operator has to check that all control and safety devices function properly.
- 2.3.3 If defects in the safety equipment or other defects are detected which impair the safe operation of the internal vibrator, the supervisor is to be notified without delay.
- 2.3.4 The machine must be switched off immediately in case of defects jeopardizing the operational safety of the equipment.
- 2.3.5 Process materials and operating fuels must be stowed away in receptacles or containers marked according to the respective manufacturers specifications.

2.4 Maintenance

- 2.4.1 Only use original spare parts. Modifications to this machine including the adjustment of the maximum speed set by the manufacturer are subject to the express approval of WACKER. In case of nonobservance all liabilities shall be refused.
- 2.4.2 All drive units have to be switched off before carrying out maintenance jobs. Deviations from this are only allowed if the maintenance or jobs require a running engine.
- 2.4.3 When working on vibratory plates equipped with electric starter, disconnect battery before carrying out maintenance or repair jobs on the electric parts of the machine.
- 2.4.4 Remove pressure from hydraulic lines before working on them. Caution: take care when removing hydraulic lines, for the oil may be very hot (up. over 80° C). Precautions are to be taken to prevent oil from splashing into the operator's eyes.
- 2.4.5 All safety devices must be reinstalled properly immediately after maintenance and repair jobs have been completed.
- 2.4.6 Do not hose down the machine with water after each use to avoid possible malfunctions. Do not use high pressure washers nor chemical products.

2.5 Transport

- 2.5.1 During transport, loading and unloading of vibration plates by means of lifting devices, appropriate slinging means or hooks have to be used on the lifting points provided for this purpose on the vibratory plate.
- 2.5.2 The load-carrying capacity of the loading ramps has to be sufficient and the ramps have to be secure such that they cannot turn over. Make sure that no one be endangered by machines turning over by slipping or by moving machine parts.
- 2.5.3 When being transported on vehicles, precautions have to be taken that vibration plates do not slip or turn over.

Safety instruction

2.6 Maintenance checks

- 2.6.1 According to the conditions and frequency of use, vibratory plates have to be checked for safe operation at least once a year by skilled technicians, such as those found at WACKER-service depots and have to be repaired if necessary.

Please also observe the corresponding rules and regulations valid in your country.

3. Technical Data

		DPU 4045H
Item no.		0610051
Operating weight		
without extension plates 440 (mm) kg:		367
kg:		390
Forward/reverse speed	m/min:	0 to 20
Surface compaction performance	m ² /h:	to 732
Power transmission		From drive engine directly to exciter unit via automatic centrifugal and V-belts
Exciter		
Vibrations	min ⁻¹ (Hz):	4140 (69)
Centrifugal force	kN:	40
Multigrade oil		Fuchs Titan Unic 10W40 MC (SAE 10W40)
Drive motor		
Air-cooled single-cylinder 4 stroke diesel engine		
Piston displacement	cm ³ :	413
Engine speed	min ⁻¹ :	2800/220
Rated power (*)	kW (PS):	5,5 (7,5)
Fuel		Diesel
Fuel consumption	l/h:	1,5
Tank capacity	l:	5,0
Oil		Fuchs Titan Unic 10W40 MC (SAE 10W40)
Hydraulic control		
Hydraulic oil		Fuchs Renolin MR 520
Special lubricating grase	L _{PA} :	92 dB(A)

Technical Data

	DPU 4045H
The weighted effective acceleration value, determined according to EN ISO 5349 m/s ² :	is 6,7

(*) In accordance with the installed useful outlet power according to Directive 2000/14/EG.

4. Description

4.1 Applications

The application range of these machines reaches from the trench and surface compaction, even with semi-cohesive soils, to the vibration of interlocking paving stones and sett pavements.

4.2 Dimensions

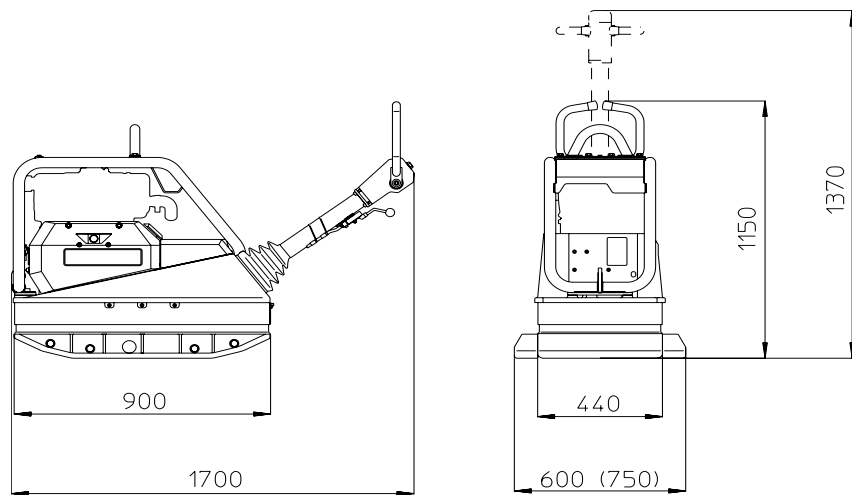

4.3 Max. admissible inclination

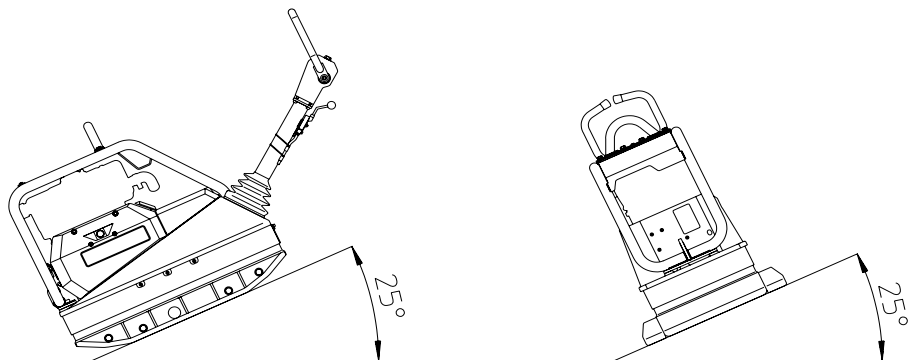

Description

4.4 Description of function

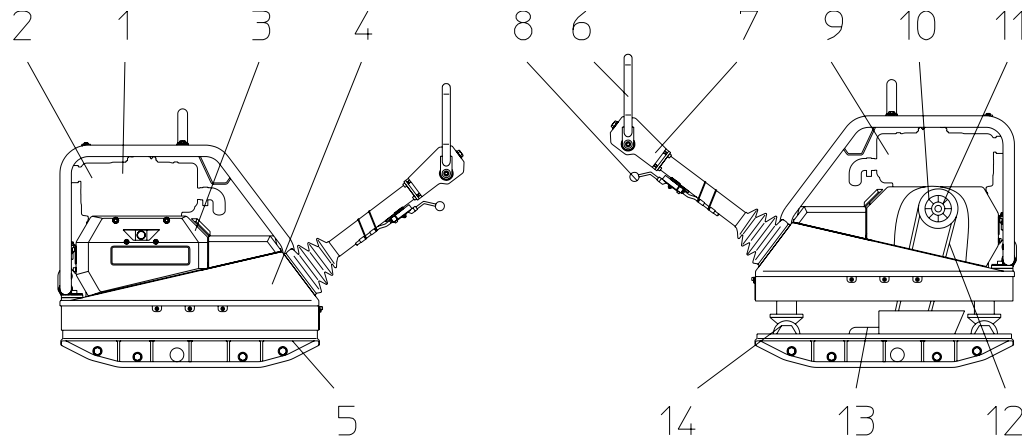

- 4.4.1 The vibration required for compaction is produced by the exciter (13) which is firmly joined to the lower mass (5). This exciter (13) is designed as a central vibrator with aligned vibrations. Such a principle permits the direction of vibration to be changed by turning the eccentric weights (15). In this way an infinitely variable transition between vibration in forward motion, at standstill and in reverse motion is possible. This process is hydraulically controlled with the operating control handle (6) on the centre pole head (7).

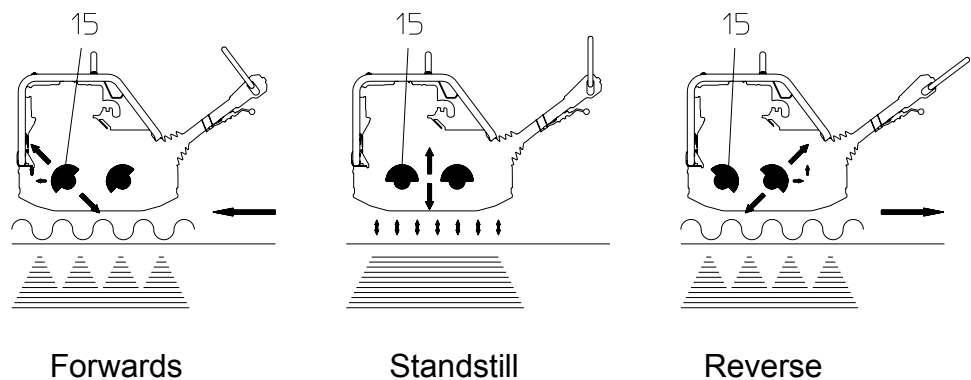

- 4.4.2 The drive engine (1) anchored to the upper mass (4) drives the exciter (13). The torque is transmitted by means of a friction connection through the centrifugal clutch (11) and the exciter V-belt (12).

- 4.4.3 The centrifugal clutch (11) interrupts flow of power to the exciter (13) at low engine speed and thus permits perfect idling of the drive engine (1).
- 4.4.4 The automatic V-belt pulley (10) combined with the centrifugal clutch (11) ensures optimum tension of the exciter V-belt (12) during operation and relief of the tension of the exciter V-belt (12) when the machine is being relocated or transported.
- 4.4.5 Moreover, the automatic V-belt pulley (10) automatically adapts to the V-belt flanks in line with the wear and thus makes the entire drive from the engine (1) to the exciter (13) maintenance-free (see chapter Exciter V-belt).
- 4.4.6 The speed of the drive engine (1) can be infinitely varied by remote control on the throttle control lever (8). The upper (4) and lower (5) masses are connected to each other by 4 vibration-damping rubber metal shock mounts (14). This damping system prevents the very high frequencies from being transmitted to the upper mass (4). As a result the functionality of the drive engine (1) is retained in spite of the high compaction performance. The drive engine (1) works on the diesel principle; it is started electrically by a pinion starter (3), draws in the combustion air through an air filter, dry (9) and is air-cooled.
- 4.4.7 To facilitate the starting procedure (at very low temperatures, with hand start) the drive engine (1) has an automatic decompression mechanism (2). It ensures that compression is very low during the cranking operation but steadily increases after a few revolutions when it then switches over to full compression.

Transport to work site /Recommendations on compaction

5. Transport to work site /Recommendations on compaction

5.1 Transport to work site

Conditions:

- * To transport the vibration plate, only use suitable lifting equipment with a minimum load-bearing capacity of 500 kg.
- * Always switch off engine before transporting the machine!
- * Vertically set guide handle head and lock into place.
- * Only attach suitable tackle at the central lifting point (18a) provided. The central lifting point is located exactly above the centre of gravity of the machine. The central lifting point can be displaced rearwards (18b), given an application in which the height of the machine is of importance (torque wrench setting = 85 Nm).
- * During transport on the loading area of a vehicle, tie down the vibration plate using the lugs (17).

Note: Also overve the regulations in safety instructions.

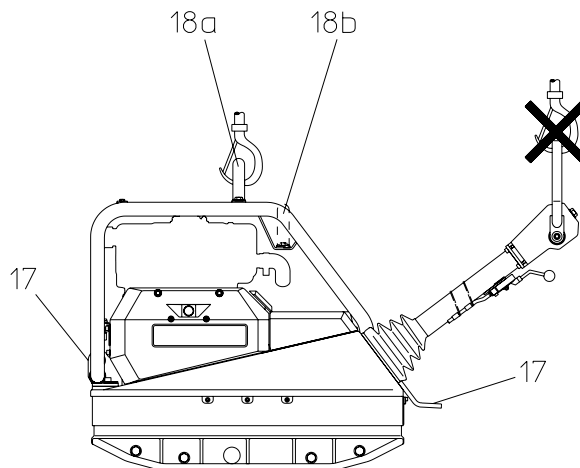

5.2 Recommendations on compaction

5.2.1 Ground conditions

The max. compaction depth depends on several factors relating to the ground condition, such as moisture, grain distribution etc, it is therefore not possible to specify exact values.

Recommendation: In each case determine the max. compaction depth with compaction tests and soil samples.

5.2.2 Compaction on slopes

The following points are to be observed when compacting on sloped surfaces (slopes, embankments):

- * Only approach gradients from the bottom (a gradient which can be easily overcome upwards, can also be compacted downwards without any risk).
- * The operator must never stand in the direction of descent.
- * The max. gradient of 25° must not be exceeded.



A tilt in excess of this angle could lead to a stopping of the engine due to the automatic low oil shut-off system. A restarting of the engine can only take place after the valve lever at the oil filter housing has been actuated once.

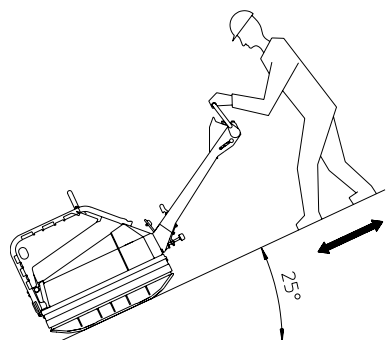

Right !

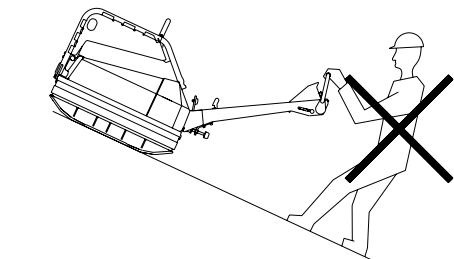

Wrong!

Operation

6. Operation

6.1 Starting

6.1.1 Conditions:

Oil:

Check oil level with oil dipstick (21), if necessary top up with Fuchs Titan Unic 10W40 MC through oil filler neck (19).

Fuel:

When pouring diesel fuel into the filler neck (20), maintain absolute cleanliness. Impurities in the fuel can cause breakdowns in the injection system and premature clogging of the fuel filter.

Air filter:

Clean air filter dry, dusty conditions.

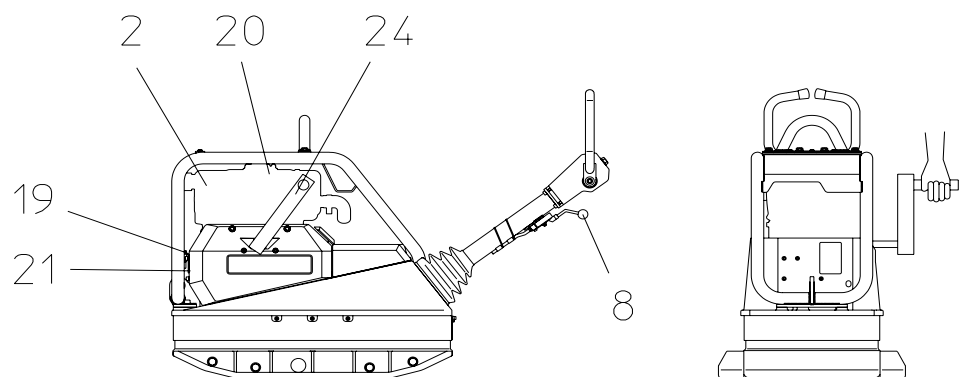

6.1.2 Once these points have been observed, you can start the engine as follows:

1. Turn the throttle control lever (8) clockwise into full load position.

2. Push decompression lever upwards.
3. Insert crank (24) into the bushing.
4. After having engaged the automatic decompression system to the stop position, the engine will require five full turns of the crank until the engine regains its compression and fires up.
5. Stand beside the engine (feet slightly apart), viewing in the forward direction.
6. Place one hand on the machine and crank with the other hand.



Keep a firm hold of the crank while cranking in order to avoid the risk of sudden slippage.

7. Turn crank slowly at first until crank engages and then increase cranking speed.
8. As soon as the engine is running, remove crank (24).
9. Turn throttle control lever (8) into idling position, allow engine to warm up for 7 minutes at idling speed.

Note: Do not activate automatic decompression lever while the engine is running.



Wait until the engine stops before repeating the starting procedure.

Operation

6.2 Mechanical oil pressure control

It is necessary to reactivate the mechanical oil pressure control in the following cases:

- * after the initial filling - first filling - of the fuel tank or if the tank has run dry.
- * in the case of an automatic engine stop due to an inefficient engine oil supply.
- * after freeing the engine when in presence of extremely low temperatures.

1. Fill up fuel tank.
2. Check engine oil level.
3. To activate depress hand lever for approx. 5 seconds.
4. Hold down pin during approx. 5 seconds in the case of encapsulated engine versions.
5. Simultaneously actuate hand lever a few times in the case of engines equipped with fuel pumps.
6. Complete engine. Check to see that encapsulating elements seal correctly.



Check oil level every 8 to 15 operating hours in spite of the mechanical oil pressure control.

6.3 Forward and reverse motion

The engine speed can be infinitely varied on the throttle control lever.

The direction of travel is determined with the shift lever (6).

Depending on the position of the shift lever (6), the vibration plate compacts in forward direction, at standstill or in reverse direction.

The forward and reverse speeds can be varied by selecting intermediate positions of the shift lever (6) or the machine can be employed for particularly intensive compaction at standstill.

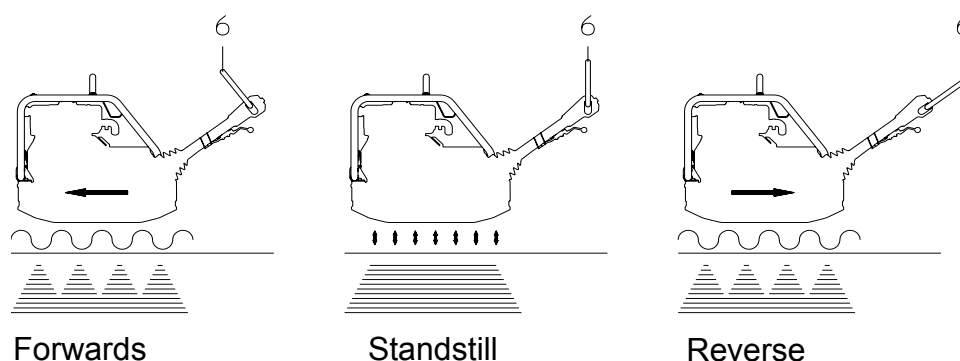

6.4 Switching off



Never switch off the engine with the automatic decompression (2) as this inevitably results in damage to the valve drive and decompression mechanism.

Move the throttle control lever (8) to the stop.

6.5 Compaction without extension plates

If the vibration plate is used without extension plates, screw set of protective screws (8 pcs) into the threaded boreholes situated in the lower mass, in order to avoid threads from being damaged.

6.6 Additional notes on starting at very low temperatures!



Never use starting sprays or similar - they are forbidden because they are dangerous.

Only use original Wacker crank.



If cranking, is too slow, the engine can start running in the opposite direction of rotation.

In this case the air is drawn in through the exhaust and the exhaust gases escape through the air filter. Risk of fire! Switch off engine and start it again.

Free the engine by turning it approximately 10 to 20 times with the decompression lever in a central position. Then the engine is decompressed, but not ready to start. This intermediate position is used to turn the engine "free" when at very low temperatures. The turning resistance becomes appreciably lower owing to the change in viscosity of the oil film. At the same time you will hear that the nozzle of the fuel injection system is injecting cleanly (rattling).

At very low temperatures (below -5°C), use the starting oil dosing device.

Note: Do not use more than 2 doses as otherwise there is a risk of crank back-swing.

7. Maintenance

7.1 Maintenance schedule

Check all external screw connections for tight fit approx. 8 hours after first operation.		
Component	Maintenance work	Maintenance interval
Drive engine	First oil change and filter.	approx. 8 hours after initial start-up
Valve clearance	Cold engine: Check valve clearance, and adjust if necessary. Inlet valve 0,1 mm - outlet valve 0,2 mm.	
Air filter	Check dry type air filter - clean or replace filter cartridge if necessary (pay attention to the maintenance indication).	daily
Drive engine	Check oil level, if nec. top up oil.	
Centre pole height setting, transport lock	Regrease.	weekly
V-belt	Check V-belt, if. nec. replace.	monthly
Protective frame	Check attachment screws for tight fit.	
Central lifting point		
Tow-bar head		
Drive engine	Oil change, change oil filter. Keep cooling fins free of dirt, clean dry. Retighten all accessible screw connections.	every 250 h
Exciter	Oil change.	
Valve clearance	Cold engine: Check valve clearance, and adjust if necessary. Inlet valve 0,1 mm - outlet valve 0,2 mm.	
Fuel filter	Change filter.	every 500 h

Maintenance

7.2 Engine oil

7.2.1 Check oil level:

- * Check oil level on oil dipstick (21).
- * .If the oil level is too low, top up with Fuchs Titan Unic 10W40 MC through the filler nozzle (19).

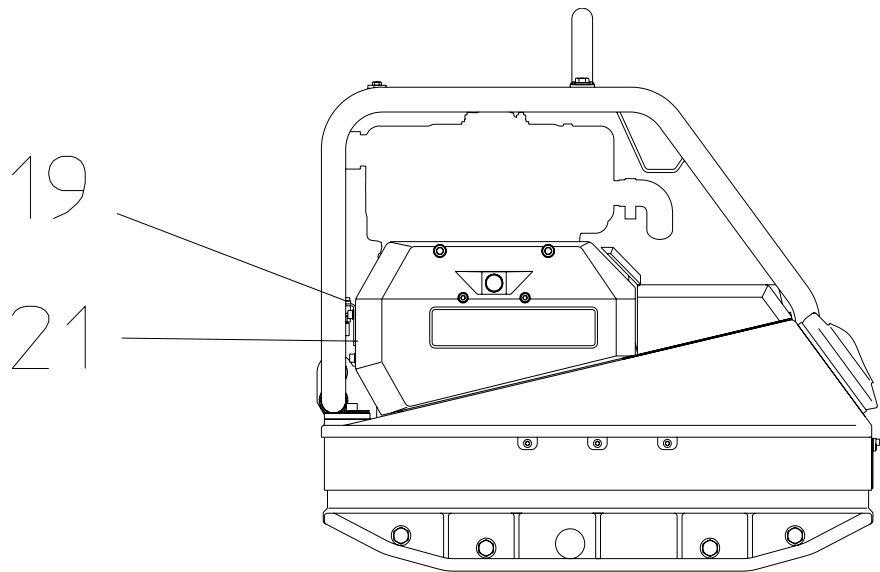

7.2.2 Changing the oil:

1. Let engine warm up.
2. Loosen oil drain screw.
3. Loosen fastening screws and place bracket over used oil container.
4. Remove oil drain screw and pour oil into container.
5. Screw oil drain screw back in and refasten bracket.
6. Pour in 1,0 l of oil through the filler nozzle (19).



Take notice: Please pay attention to the corresponding environmental laws when disposing of used engine oil. We recommend you carry the oil in a container to a central collecting point for used oils. Do not pour used engine oil into the garbage nor into the sewer system, waste pipes or even on the ground.

7.3 Hydraulic control

7.3.1 Check oil level:

1. Move centre pole into vertical position.
2. Open filler bore (26).
3. Oil level must be at mark, if necessary top up with hydraulic oil Fuchs Renolin MR 520.
4. Close filler bore (26).

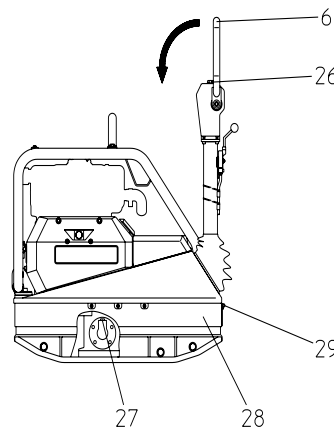

7.3.2 Venting hydraulic control:

1. Remove apron (28) by undoing the screws (29).
2. Move centre pole into vertical position, move shift lever (6) right into the reverse position, open filler bore (26).
3. Loosen connecting screw (27).
4. Slowly push the shift lever (6) into forward motion direction until hydraulic oil emerges bubblefree at the connection screw.
5. Tighten connecting screw (27), mount apron (28).
6. If necessary, top up with Fuchs Renolin MR 520, seal filler bore (26).

Maintenance

7.4 Exciter

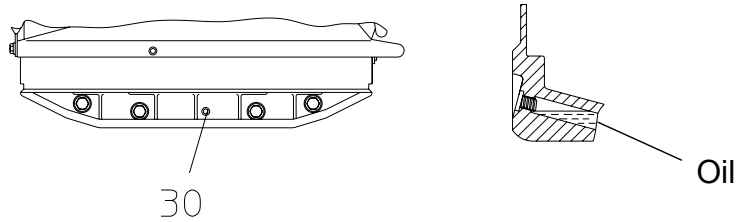

7.4.1 Check oil level:

1. Position vibration plate horizontally.
2. Open filler bore (30).
3. The oil level must reach the start of the thread of the filler bore.
4. If necessary, pour in Fuchs Titan Unic 10W40 MC through filler bore (use funnel 0,75 l).
5. Close filler bore. (Tightening torque 100 Nm)

7.4.2 Changing the oil:

1. Open filler bore (30).
2. Tilt vibration plate and keep it tilted until the oil has run out.
3. Place vibration plate in horizontal position.
4. Pour in 0,75 l Fuchs Titan Unic 10W40 MC through the filler bore.
5. Close filler bore. (Tightening torque 100 Nm)

Do not pour in too much oil!



Take notice: Please pay attention to the corresponding environmental laws when disposing of used engine oil. We recommend you carry the oil in a container to a central collecting point for used oils. Do not pour used engine oil into the garbage nor into the sewer system, waste pipes or even on the ground.

7.5 Exciter V-belt

It is not necessary to retighten the V-belt owing to the use of the automatic centrifugal clutch.

Should the V-belt width fall below 15,5 mm the V-belt must be replaced.

7.5.1 Changing the exciter V-belt:

1. Remove belt guard (31).
2. Undo screw (32).
3. Remove button (33), belleville spring (34), seal (35) and front segment of the V-belt pulley (10).
4. Change exciter V-belt (12).
5. Assemble the components in reverse order; make sure that the coloured marking on the pin (36) coincides with the marking on the V-belt pulley (10).



Do not oil or grease clutch components (will damage the graphite bushes).

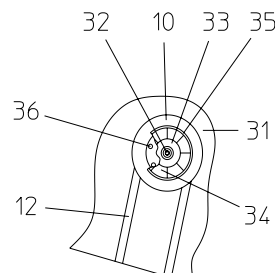

Faults

8. Faults

8.1 Forward speed too low

Cause	Remedy
To little hydraulic oil in the centre pole head.	Top up hydraulic oil.
Air in hydraulic control.	Bleed system.

8.2 Reverse speed too low

Cause	Remedy
Too much hydraulic oil in centre pole head.	Correct oil level in accordance with mark.

8.3 No reverse motion

Cause	Remedy
Mechanical fault.	Contact Wacker service dept.

8.4 Loss of hydraulic oil

Cause	Remedy
Leaks, hydraulic hose defective.	Change defective parts. Note: Bleed system after every dismantling operation.

8.5 Engine does not start

Cause	Remedy
Lack of lubricating oil.	Fill up with oil and actuate valve lever at oil filter housing once.

Lables

9. Lables

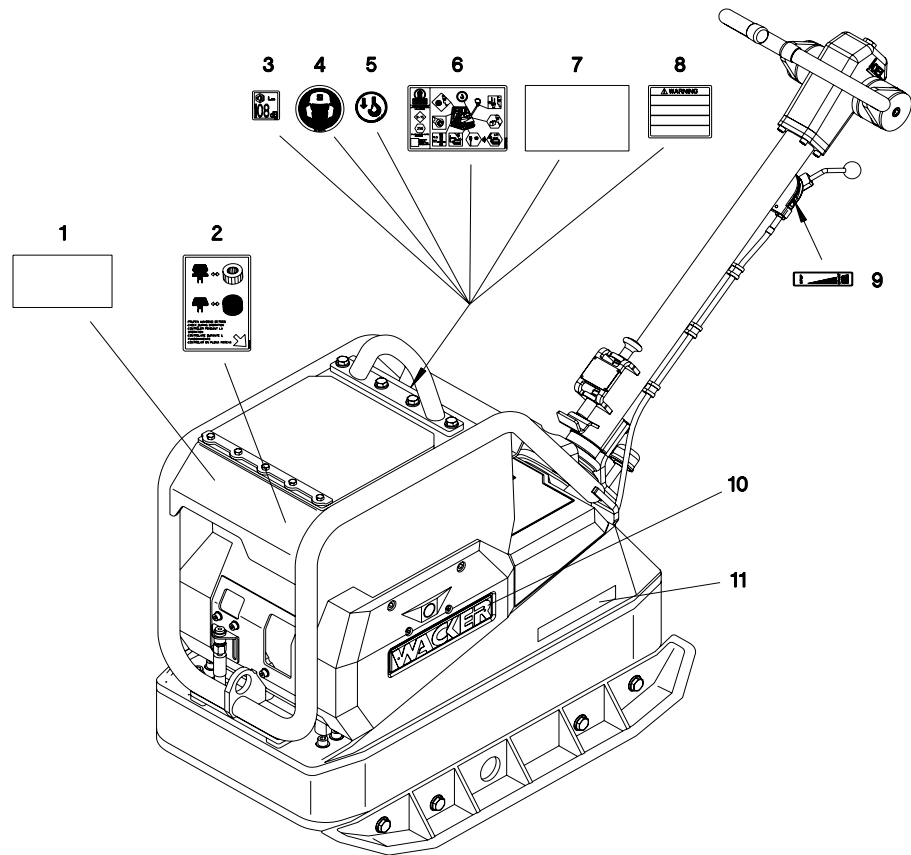

1	Notice-Starting procedure
2	Notice-Air cleaner service indicator Inspect during engine operation
3	Sound power level
4	Ear protection decal
5	Notice-Lifting point
6	Notice-Maintenance
7	Maintenance decal
8	Warning notice - Do not run without protective devices. - Read operator's manual in detail.
9	Start-Stop
10	Wacker-Logo
11	Type

EG - Konformitätserklärung EC - Conformity Certificate

Wacker Construction Equipment AG, Preußenstraße 41, 80809 München

bescheinigt, daß das Baugerät:

hereby certify that the construction equipment specified hereunder:

1. Art / Category:

Vibrationsplatte / Vibratory plate

2. Typ / Type:

DPU 4045H

3. Gerätetypnummer / Equipment item number:

0610051

4. absolute installierte Leistung / Absolute installed power:

5,5 kW

in Übereinstimmung mit Richtlinie 2000/14/EG bewertet worden ist:
has been evaluated in conformity with Directive 2000/14/EC:

Konformitätsbewertungsverfahren Conformity assessment procedure	Bei folgender einbezogener Prüfstelle At the following notified body	Gemessener Schalleistungspegel Measured sound power level	Garantierter Schalleistungspegel Guaranteed sound power level
Anhang VIII Annex VIII	VDE Prüf- und Zertifizierungsinstitut Zertifizierungsstelle Merianstraße 28 63069 Offenbach/Main	107 dB(A)	108 dB(A)

und in Übereinstimmung mit folgenden Richtlinien hergestellt worden ist:
and has been manufactured in accordance with the following directives:

* 2000/14/EG

* 98/37/EG

EN 500-1

EN 500-4

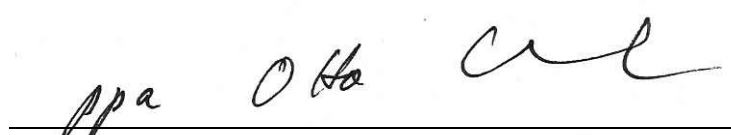

Dr. Stenzel
Leitung Forschung und Entwicklung
Research and Development Management

VDE Prüf- und Zertifizierungsinstitut

VDE VERBAND DER ELEKTROTECHNIK
ELEKTRONIK INFORMATIONSTECHNIK e.V.

CERTIFICATE

Registration-Number: 6236/QM/06.97

This is to certify that the company

WACKER



**Wacker Construction Equipment AG
Wacker-Werke GmbH & Co. KG**

at the following locations

**Head Office Munich
Preußenstraße 41
80809 Munich**

**Production plant Reichertshofen
Karlsfeld logistics centre
Sales regions with all branches all over Germany**

has implemented and maintains a
Quality Management System for the following scope:

**Machine manufacture
Construction machines**

This Q System complies with the requirements of

DIN EN ISO 9001:2000

and the requirements of the German and international Road Traffic Act.

This Certificate is valid until 2009-06-05.

VDE Testing and Certification Institute
Certification

Date: 2003-05-30

63069 Offenbach, Merianstraße 28
Telefon: +49 (0) 69 83 06-0, Telefax: +49 (0) 69 83 06-555
E-Mail: vde-institut@vde.com, <http://www.vde-institut.com>



The VDE Testing and Certification Institute is accredited by DAR Accreditation
Bodies according to DIN EN ISO 17020 and DIN EN ISO 45012 and notified in the EU
under ID.No. 0366.

TGA-ZM-09-92-00
KBA-ZM-A 00021-97

