

0226268en	002
03.2010	

Vibratory plate

DPU 6555He

Operator's Manual



Manufacturer

Wacker Neuson SE
Preußenstraße 41
80809 München
www.wackerneuson.com
Tel.: +49-(0)89-354 02-0
Fax: +49-(0)89-354 02-390

Translation of the original operator's manual in German



**WACKER
NEUSON**

1 Foreword

This operator's manual contains information and procedures for the safe operation and maintenance of your Wacker Neuson machine. In the interest of your own safety and to prevent accidents, you should carefully read through the safety information, familiarize yourself with it and observe it at all times.

This operator's manual is not a manual for extensive maintenance and repair work. Such work should be carried out by Wacker Neuson service or authorized specialists.

The safety of the operator was one of the most important aspects taken into consideration when this machine was designed. Nevertheless, improper use or incorrect maintenance can pose a risk. Please operate and maintain your Wacker Neuson machine in accordance with the instructions in this operator's manual. Your reward will be troublefree operation and a high degree of availability.

Defective machine parts must be replaced immediately!

Please contact your Wacker Neuson representative if you have any questions concerning operation or maintenance.

All rights reserved, especially reproduction and distribution rights.

Copyright 2010 Wacker Neuson SE

No part of this publication may be reproduced in any form or by any means, electronic or mechanical, including photocopying, without the expressed written permission of Wacker Neuson.

Any type of reproduction, distribution or storage on data media of any type and form not authorized by Wacker Neuson represents an infringement of copyright and will be prosecuted.

We expressly reserve the right to make technical modifications – even without special notice – which aim at further improving our machines or their safety standards.

Table Of Contents

1. Technical Data	20
2. Description	22
2.1 Max. admissible inclination	22
2.2 Description of function	22
3. Transport to work site /Recommendations on compaction	24
3.1 Transport to work site	24
3.2 Recommendations on compaction	26
4. Operation	27
4.1 Starting	27
4.2 Mechanical oil pressure control	28
4.3 Electric start	30
4.4 Starting the engine with the safety starting crank	32
4.5 Starting in cold weather	35
4.6 Starting with external battery etc.	37
4.7 Forward and reverse motion	38
4.8 Compaction without extension plates	38
4.9 Stopping the engine	39
5. Maintenance	40
5.1 Maintenance schedule	40
5.2 Engine oil and oil filter	41
5.3 Air filter	43
5.4 Fuel system	45
5.5 Battery	47
5.6 Hydraulic control	48
5.7 Exciter	49
5.8 Exciter V-belt	51
6. Faults	52
6.1 Forward speed too low	52
6.2 Reverse speed too low	52
6.3 No reverse motion	52
6.4 Loss of hydraulic oil	52
6.5 The charge control lamp will not extinguish	53
6.6 Engine does not start	53

2 Safety

2.1 Principle

State of the art

This machine has been constructed with state-of-the-art technology according to the recognized rules of safety. Nevertheless, when used improperly, dangers to the life and limb of the operator or to third persons or damage to the machine or other materials cannot be excluded.

Proper use

The machine must only be used for the following purposes:

- Compaction of soils.
- Compaction of asphalt.
- Shaking in of paving stones.

The machine may not be used for the following purposes:

- Compaction of intensely cohesive soils.
- Compaction of frozen soils.
- Compaction of hard, non-compactable soils.
- Compaction of soils that are not capable of bearing a load.

Its proper use also includes the observance of all instructions contained in this operator's manual as well as complying with the required service and maintenance instructions.

Any other use is regarded as improper. Any damage resulting from improper use will void the warranty and the liability on behalf of the manufacturer. The operator assumes full responsibility.

Structural modifications

Never attempt to modify the machine without the written permission of the manufacturer. To do so will endanger your safety and the safety of other people! In addition, this will void the warranty and the liability on behalf of the manufacturer.

Especially the following are cases of structural modifications:

- Opening the machine and the permanent removal of components from Wacker Neuson.
- Installing new components which are not from Wacker Neuson and not equivalent to the original parts in design and quality.
- Installation of accessories which are not from Wacker Neuson.

It is no problem to install spare parts from Wacker Neuson.

It is no problem to install accessories that are available in the Wacker Neuson product range of your machine. Please refer to the installation regulations in this operator's manual.

Requirements for operation

The ability to operate the machine safely requires:

- Proper transport, storage and setup.
- Careful operation.
- Careful service and maintenance.

Operation

Operate the machine only as intended and only when in proper working condition.

Operate the machine in a safety-conscious manner with all safety devices attached and enabled. Do not modify or disable any safety devices.

Before starting operation, check that all control and safety devices are functioning properly.

Never operate the machine in a potentially explosive environment.

Supervision

Never leave the machine running unattended!

Maintenance

Regular maintenance work is required in order for the machine to operate properly and reliably over time. Failure to perform adequate maintenance reduces the safety of the machine.

- Strictly observe the prescribed maintenance intervals.
- Do not use the machine if it requires maintenance or repairs.

Malfunctions

If you detect a malfunction, you must shut down and secure the machine immediately.

Eliminate the malfunctions that impair safety immediately!

Have damaged or defective components replaced immediately!

For further information, refer to chapter *Troubleshooting*.

Spare parts, accessories

Use only spare parts from Wacker Neuson or such that are equivalent to the original parts in design and quality.

Only use accessories from Wacker Neuson.

Non-compliance will exempt the manufacturer from all liability.

Exclusion of liability

Wacker Neuson will refuse to accept liability for injuries to persons or for damage to materials in the following cases:

- Structural modifications.
- Improper use.
- Failure to comply with this operator's manual.
- Improper handling.
- Using of spare parts which are not from Wacker Neuson and not equivalent to the original parts in design and quality.
- Using of accessories which are not from Wacker Neuson.

Operator's manual

Always keep the operator's manual near the machine or near the worksite for quick reference.

If you have misplaced the operator's manual or require an additional copy, contact your Wacker Neuson representative or download the operator's manual from the Internet (www.wackerneuson.com).

Always hand over this operator's manual to other operators or to the future owner of the machine.

Country-specific regulations

Observe the country-specific regulations, standards and guidelines in reference to accident prevention and environmental safety, for example those pertaining to hazardous materials and wearing protective gear.

Complement the operator's manual with additional instructions taking into account the operational, regulatory, national or generally applicable safety guidelines.

Operator's controls

Always keep the operator's controls of the machine dry, clean and free of oil or grease.

Operating elements such as ON/OFF switch, gas handles etc. may not be locked, manipulated or changed without authorization.

Cleaning

Always keep the machine clean and be sure to clean it each time you have finished using it.

Do not use gasoline or solvents. Danger of explosion!

Do not use high pressure washers. Permeating water can damage the machine. When electrical equipment is present, this can pose a serious injury risk from electric shocks.

Checking for signs of damage

Inspect the machine when it is switched off for any signs of damage at least once per work shift.

Do not operate the machine if there is visible damage or defects.

Have any damage or defects eliminated immediately.

2.2 Qualification of the operating personnel

Operator qualifications

Only trained personnel are permitted to start and operate the machine. The following rules also apply:

- You are at least 18 years of age.
- You are physically and mentally fit.
- You have received instruction on how to independently operate the machine.
- You have received instruction in the proper use of the machine.
- You are familiar with required safety devices.
- You are authorized to start machines and systems in accordance with the standards governing safety.
- Your company or the operator has assigned you to work independently with this machine.

Incorrect operation

Incorrect operation or misuse by untrained personnel can endanger the health and safety of the operator or third persons and also cause machine and material damage.

Operating company responsibilities

The operating company must make the operator's manual available to the operator and ensure that the operator has read and understood it.

Work recommendations

Please observe the recommendations below:

- Work only if you are in a good physical condition.
- Work attentively, particularly as you finish.
- Do not operate the machine when you are tired.
- Carry out all work calmly, circumspectly and carefully.
- Never operate the machine under the influence of alcohol, drugs or medication. This can impair your vision, reactions and your judgment.
- Work in a manner that does not endanger others.
- Ensure that no persons or animals are within the danger zone.

2.3 Protective gear

Work clothing

Clothing should be appropriate, i.e. should be close-fitting but not restrict your movement.

When on construction sites, do not wear long hair loosely, loose clothing or jewelry including rings. These objects can easily get caught or be drawn in by moving machine parts.

Only wear clothing made of material that is not easily flammable.

Personal protective gear

Wear personal protective gear to avoid injuries or health hazards:

- Non-skid, hard-toed shoes.
- Work gloves made of durable material.
- Overalls made of durable material.
- Hard hat.
- Ear protection.

Ear protection

This machine generates noise that exceeds the country-specific permissible noise levels (individual rating level). It may therefore be necessary to wear ear protection. You can find the exact value in the chapter *Technical Data*.

When wearing ear protection while working, you must pay attention and exercise caution because your hearing is limited, e.g. in case someone screams or a signal tone sounds.

Wacker Neuson recommends that you always wear ear protection.

2.4 Transport

Switching off the machine

Before you transport the machine, it must be switched off, and the engine must be given sufficient time to cool down.

Center pole in transport position

Before commencing transport, move the center pole to the transport position. Let the center pole latch into its lock.

Observing hazardous materials regulations

Observe the national safety guidelines and the hazardous materials regulations that apply to the respective means of transportation.

Lifting

When lifting the machine, observe the following instructions:

- Designate a skilled person to guide you for the lifting procedure.
- You must be able to see or hear this person.
- Use only suitable and certified hoisting gear, lifting tackle and load-bearing equipment with sufficient lifting capacities.
- Only use the attachment points described in the operator's manual.
- Attach the machine securely to the hoisting gear.
- Ensure that no one is nearby or under the machine.
- Do not climb onto the machine.

Loading the machine

Loading ramps must be able to bear the load and be in a stable position.

Make sure that no one can be endangered if the machine slips away or tips over or if machine parts suddenly move upward or downward.

Put the operating controls and moving parts in their transport position.

Secure the machine with load-securing straps so that it cannot tip over, fall down or slide away. Only use the attachment points described in the operator's manual.

Transport vehicle

Use only suitable transport vehicles with sufficient load-carrying capacity and suitable tie-down lugs.

Transporting the machine

Secure the machine on the transport device against tilting, falling or slipping.

Only use the lashing points listed in the operating instructions.

Also observe the country-specific regulations, standards and guidelines.

Restarting

Machines, machine parts, accessories or tools that were detached for transport purposes must be re-mounted and fastened before restarting.

Only operate in accordance with the operating instructions.

2.5 Operating safety

Explosible environment

Never operate the machine in a potentially explosive environment.

Work environment

Familiarize yourself with your work environment before you start work. This includes e.g. the following items:

- Obstacles in the work and traffic area.
- Load-bearing capacity of the ground.
- The measures needed to cordon off the construction site from public traffic in particular.
- The measures needed to secure walls and ceilings.
- Options available in the event of an accident.

Safety in the work area

When working with the machine especially pay attention to the following points:

- Electric lines or pipes in work area.
- Gas lines or water lines in the work area.

Starting the machine

Observe the safety information and warning notices located on the machine and in the operator's manual.

Never attempt to start a machine that requires maintenance or repairs.

Start the machine as directed in the operator's manual.

Vertical stability

Always ensure that the machine is vertically stable and cannot tip over, roll or slide away.

Proper operator position

Do not leave the proper operator position while operating the machine.

The proper operator position is behind the center pole of the machine.

Leaving the danger area

Injury may be caused by moving machines or flying materials.

Ensure that other persons observe a minimum safety distance of 2 m from the machine.

Caution with movable parts

Keep your hands, feet and loose clothing away from moving or rotating machine parts. Parts of your body being pulled in or crushed can cause serious injuries.

Switching off the machine

Switch off the engine in the following situations:

- Before breaks.
- If you are not using the machine.

Store the machine in such a way that it cannot tilt, fall or slip.

Storage location

After operation, allow the machine to cool and then store it in a sealed-off, clean and dry location protected against frost and inaccessible to children.

Not using starter sprays

Highly flammable starter sprays pose a fire hazard.

Do not use any starter sprays.

Starter sprays are highly flammable and can cause backfiring and engine damage.

Vibrations

When manually operated machines are intensively used, long-term damage caused by vibrations cannot be precluded.

Observe the relevant legal instructions and guidelines to minimize vibration stress.

Details on vibration stress associated with the machine can be found in the chapter *Technical Data*.

2.6 Safety during the operation of vibratory plates

Integrated driving mechanism

Machines with integrated driving mechanism must not be set down or stored on the transport device. The driving mechanism is only intended for transport.

Belt guard

Never operate the machine without a belt guard!

Exposed belts and belt pulleys are dangerous and can cause serious injuries if they pull in any part of your body or if parts are ejected.

Danger of falling over

Operate the machine so that it cannot tip over or fall down from bordered areas, edges and steps.

Load-carrying capacity of the ground

Keep in mind that the load-carrying capacity of the earth to be compressed or bed can be greatly reduced by the effects of vibration, for example near slopes.

Avoiding crushing

When operating the machine, pay particular attention to avoid being squeezed between the machine and an obstacle. Always look in the direction of travel!

Compacting on slopes

The following points must be observed if you plan to compact inclined surfaces (slopes, escarpments):

- Always stand above the machine on a slope.
- Start at the bottom of a slope (slopes that can be easily managed in an upward direction can be safely traveled in a downward direction also).
- Never stand in a position where the machine could possibly fall. A slipping or tipping machine can cause serious injuries.

Not exceeding the maximum tilt position

- Do not exceed the maximum tilt position (see chapter *Technical Data*).
- Only operate the machine at maximum tilt for short periods of time.

If you exceed the maximum tilt, the engine lubrication system will fail and thus inevitably damage important engine parts.

Check the effects of vibration

Compacting work in the vicinity of buildings can lead to structural damage. For this reason you must always check the possible effects of vibrations on surrounding buildings in the run-up to work.

You must take the following points into special consideration when evaluating the effects of vibration:

- Vibration behavior, sensitivity and resonance frequency of surrounding buildings.
- Distance of the buildings from the vibrationsite (= worksite).
- Condition of the soil.

You may need to carry out measurements to determine the vibration speed.

You must also comply with the relevant guidelines and regulations, particularly DIN 4150-3.

The foundation must also have sufficient load-bearing capacity to withstand the compaction energy. In case of doubt involve a soil mechanics specialist in the evaluation.

Wacker Neuson is not liable for any structural damage.

2.7 Safety during the operation of combustion engines

Checking for signs of damage

Check the engine while switched off for leaks and cracks in the fuel line, tank and fuel cap at least once per work shift.

Do not operate the machine if there is visible damage or defects.

Have any damage or defects eliminated immediately.

Dangers during operation

Combustion engines can be dangerous, particularly during operation and when refueling.

Read and follow all safety instructions. Otherwise there is a risk of personal injury and/or damage to property!

Do not start the engine near spilt fuel or if you smell fuel – this may cause an explosion!

- Remove the machine from such areas.
- Remove the spilt fuel immediately!

Not changing the engine speed

Do not change the preset engine speed, as this may cause engine damage.

Preventing fires

Open flames and smoking are strictly prohibited in the immediate vicinity of the machine.

Make sure that waste, such as paper, dry leaves or grass do not accumulate around the exhaust muffler. The waste materials may ignite.

Safety precautions when refueling

Please observe the following safety-relevant instructions when refueling:

- Do not refuel near open flames.
- Do not smoke.
- Turn off the engine before refueling and allow it to cool down.
- Refuel in a well-ventilated environment.
- Wear fuel-proof protective gloves and, if there is the possibility of spraying, protective goggles and clothing.
- Do not inhale fuel vapors.
- Avoid skin and eye contact with fuel.
- For refueling, use clean tools such as a hopper.
- Do not spill fuel, especially onto hot parts.
- Remove any spilt fuel immediately.
- Use the correct fuel grade.
- Do not mix fuel with other liquids.
- Fill the tank only up to the maximum marking. If there is no Maximum marking, do not fill up the tank completely.
- Lock the fuel cap securely after refueling.

Operation in closed rooms

In closed or partially closed rooms such as tunnels, drifts or deep trenches, ensure sufficient ventilation and extraction by, for example, providing a powerful exhaust air fan.

Danger of poisoning! Do not inhale exhaust fumes. They contain toxic carbon monoxide that can lead to unconsciousness or death.

Caution with hot parts

Do not touch any hot parts such as the engine block or exhaust muffler during operation or directly afterwards. These parts can become very hot and cause severe burns.

Cleaning the engine

Clean the engine when it is cool to remove any dirt.

Do not use gasoline or solvents. Danger of explosion!

Notes on the EPA engine

Caution

This machine is equipped with an EPA-certified engine.

Modifying the motor speed influences the EPA certification and emission. The motor may only be set by a skilled technician.

For more detailed information, contact your nearest motor or Wacker Neuson representative.

Health hazard due to exhaust fumes

Warning

The engine's exhaust fumes contain chemicals which are known to the State of California to cause cancer, congenital defects or other reproductive anomalies.

2.8 Safety during the operation of hydraulic machines**Hydraulic oil**

Hydraulic oil is harmful to health.

Wear safety glasses and safety gloves when handling hydraulic oil.

Avoid direct skin contact with hydraulic oil. Remove hydraulic oil from the skin immediately with soap and water.

Make sure that no hydraulic oil comes gets in the eyes or on the body. See a physician immediately if hydraulic oil gets into the eyes or is swallowed.

Do not eat and drink while handling hydraulic oil.

Make sure to have extreme cleanliness. Contamination of the hydraulic oil with dirt or water can cause premature wear or failure of the machine.

Dispose of left over and spilled hydraulic oil according to the applicable regulations for environmental protection.

2.9 Maintenance**Maintenance work**

Service and maintenance work must only be carried out to the extent described in these operating instructions. All other procedures must be performed by your Wacker Neuson representative.

For further information, refer to chapter *Maintenance*.

Switching off the engine

Before carrying out care or maintenance work, switch off the engine and allow it to cool down.

For gasoline powered engines, you must pull off the spark plug cap.

Disconnecting the battery

For machines with electric starter, you must disconnect the battery before working on the electronic parts.

Using only a Wacker Neuson battery

Use only Wacker Neuson batteries to replace defective batteries, see chapter *Technical Data*.

Only the Wacker Neuson battery is vibration resistant and thus suitable for the high vibratory stresses.



Working on the battery

Always take the following safety measures when working with the battery:

- No fire, sparks, or smoking while working with batteries.
- Batteries contain corrosive acid. Use acid-proof protective gloves and protective goggles when working with batteries.
- Avoid short circuits due to improper connection or bypassing with tools.
- Disconnect the negative terminal first when disconnecting the battery.
- Connect the positive terminal first when connecting the battery.
- Re-fasten terminal covers after connecting the battery.

Assembling safety devices

If it was necessary to dismantle safety devices, they must be reassembled and checked immediately after completing maintenance work.

Always tighten loosened screw connections, complying with prescribed starting torque.

Handling operating fluids safely

Observe the following points when handling operating fluids, e.g. fuels, oils, greases, coolants etc.:

- Always wear personal safety clothing.
- Avoid skin and eye contact with operating fluids.
- Do not inhale or swallow operating fluids.
- In particular, avoid contact with hot operating fluids. Burn and scalding hazard.
- Dispose of replaced or spilled operating fluids according to the applicable regulations for environmental protection.
- If operating fluids escape from the machine, cease operation of the machine and have it repaired immediately by your Wacker Neuson representative.





2.10 Safety and information labels

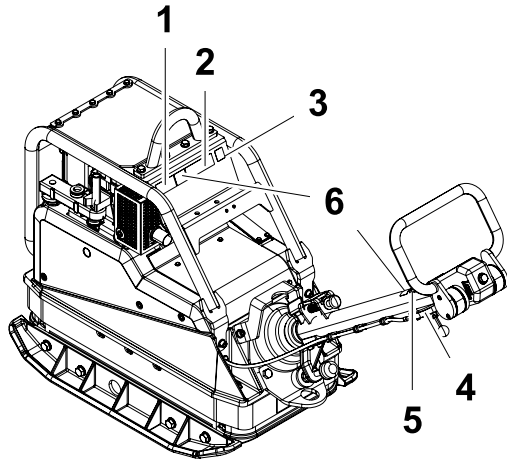

Your machine has adhesive labels containing the most important instructions and safety information.

- Make sure that all the labels are kept legible.
- Replace any missing or illegible labels.

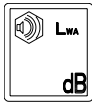
The item numbers for the labels are in the parts book.



Pos.	Label	Description
1		Wear personal protective gear to avoid injuries or health hazards: <ul style="list-style-type: none"> ■ Ear protection. Read the operator's manual before start-up.
2		If the machine falls, it can cause severe crushing injuries. <ul style="list-style-type: none"> ▶ Only lift the machine with certified hoist and lifting tackle (safety load hook). ▶ Do not lift the machine with the excavator shovel by the central suspension. ▶ Do not lift the machine with a forklift by the central suspension.
3		Guaranteed sound power level.
4		Start-Stop.

Pos.	Label	Description
5		If the machine falls, it can cause severe crushing injuries. ▶ Do not lift the machine by the guide handle or the center pole.
6	US machines 	Warning

Technical Data

1. Technical Data

	DPU 6555He		DPU 6555Heap
Item no.	0610354	0610357	0610356
Length x width x height mm:	1700 x 714 x 1190		
Operating weight kg:	484		504
Forward/reverse speed m/min:	28		27
Surface compaction performance m ² /h:	1193		1402
Power transmission	From drive engine directly to exciter unit via automatic centrifugal and V-belts		
Exciter			
Vibrations Hz:	69		
Centrifugal force kN:	65		
Oil	Fuchs Titan Unic 10W40 MC (SAE 10W40)		
Oil quantity l:	0,75		
Drive motor			
Air-cooled single-cylinder 4 stroke diesel engine with electric starter			
Piston displacement cm ³ :	667		
Rated power (*) kW:	9,9		
at rpm min ⁻¹ :	2950		
Operating rpm's min ⁻¹ :	3050		
No-load rpm's min ⁻¹ :	3140		
Oil	Fuchs Titan Unic 10W40 MC (SAE 10W40)		
Oil quantity l:	1,9		
Fuel	Diesel		

Technical Data

		DPU 6555He	DPU 6555Heap
Fuel consumption	l/h:	1,9	
Tank capacity	l:	7,0	
Electrical system			
Battery		Special Wacker Neuson-battery for vibro plates - 12 V - 55 Ah	
Alternator		Rotary current generator with electronic regulator and rectifier	
Charging rate max.	A:	26	
Charging voltage	V:	14	
Starter		Starter motor	
D.C.	V:	12	
Hydraulic control			
Oil		Fuchs Renolin MR 520	
Oil quantity	l:	0,4	
Special lubricating grase	L_{PA} :	97 dB(A)	
The weighted effec-tive acceleration value, determined according to EN ISO 5349	m/s^2 :	3,6	
Uncertainty K	m/s^2 :	1,0	

(*) In accordance with the installed useful outlet power according to Directive 2000/14/EG.

Description

2. Description

2.1 Max. admissible inclination

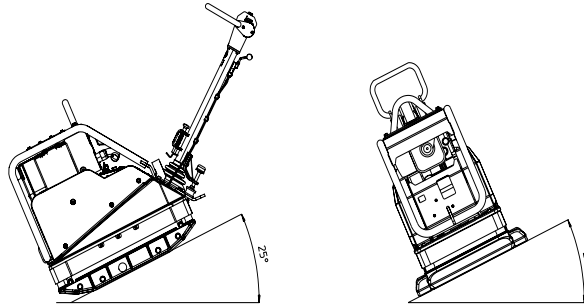

2.2 Description of function

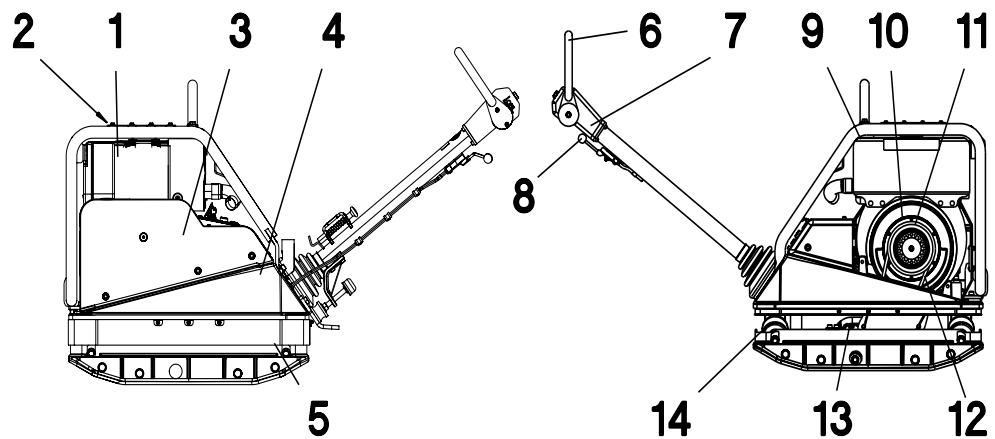

- 2.2.1 The vibration required for compaction is produced by the exciter (13) which is firmly joined to the lower mass (5). This exciter (13) is designed as a central vibrator with aligned vibrations. Such a principle permits the direction of vibration to be changed by turning the eccentric weights (15). In this way an infinitely variable transition between vibration in forward motion, at standstill and in reverse motion is possible. This process is hydraulically controlled with the operating control handle (6) on the centre pole head (7).

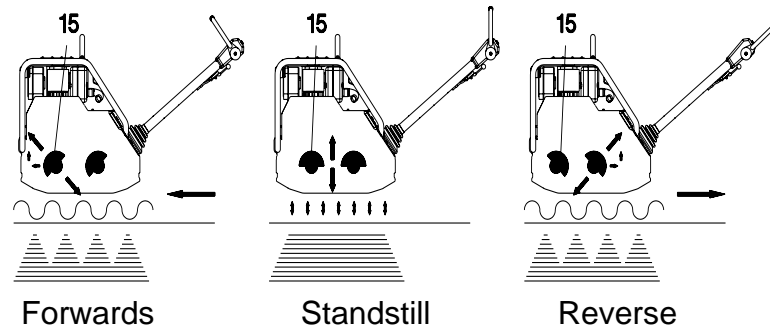

- 2.2.2 The drive engine (1) anchored to the upper mass (4) drives the exciter (13). The torque is transmitted by means of a friction connection through the centrifugal clutch (11) and the exciter V-belt (12).
- 2.2.3 The centrifugal clutch (11) interrupts flow of power to the exciter (13) at low engine speed and thus permits perfect idling of the drive engine (1).
- 2.2.4 The automatic V-belt pulley (10) combined with the centrifugal clutch (11) ensures optimum tension of the exciter V-belt (12) during operation and relief of the tension of the exciter V-belt (12) when the machine is being relocated or transported.
- 2.2.5 Moreover, the automatic V-belt pulley (10) automatically adapts to the V-belt flanks in line with the wear and thus makes the entire drive from the engine (1) to the exciter (13) maintenance-free (see chapter Exciter V-belt).
- 2.2.6 The speed of the drive engine (1) can be infinitely varied by remote control on the throttle control lever (8). The upper (4) and lower (5) masses are connected to each other by 4 vibration-damping rubber metal shock mounts (14). This damping system prevents the very high frequencies from being transmitted to the upper mass (4). As a result the functionality of the drive engine (1) is retained in spite of the high compaction performance. The drive engine (1) works on the diesel principle; it is started electrically by a pinion starter (3), draws in the combustion air through an air filter, dry (9) and is air-cooled.
- 2.2.7 To facilitate the starting procedure (at very low temperatures, with hand start) the drive engine (1) has an automatic decompression mechanism (2). It ensures that compression is very low during the cranking operation but steadily increases after a few revolutions when it then switches over to full compression.

Transport to work site /Recommendations on compaction

3. Transport to work site /Recommendations on compaction



Warning

Improper use can result in injury or serious material damage.

- * Read and follow all the safety instructions at the beginning of this operator's manual, see chapter *Safety information*.

3.1 Transport to work site



Danger

Danger of fire and explosions by fuel!

Any fuel that escapes can ignite and cause severe burns.

- * Lift and move the machine in the upright position.

Requirements:

- * When transporting the vibrating plate compactor, use only suitable hoisting gear with a minimum load-bearing capacity, see *Technical data*.
- * Always turn off the motor during transportation!

Note

We recommend that the fuel tank be emptied and the carburetor run dry prior to transporting it. Fuel could run out, e.g. if the machine is tilted.

- * Vertically set guide handle head and lock into place.



Warning

Danger due to the machine falling!

If the machine falls, it can cause severe injury such as crushing.

- * Only use suitable and tested hoisting gear and lifting tackle (safety load hooks) of sufficient lifting capacity.
- * Attach the machine firmly to the hoisting gear.

Transport to work site /Recommendations on compaction

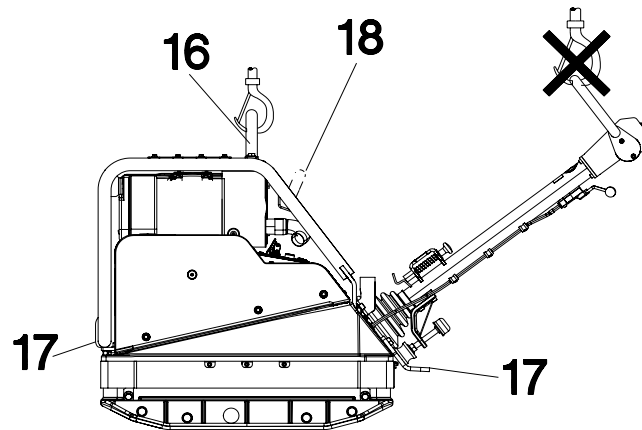

- * Only attach suitable tackle at the central lifting point (16) provided. The central lifting point is located exactly above the centre of gravity of the machine. The central lifting point can be displaced rearwards (18), given an application in which the height of the machine is of importance (torque wrench setting = 85 Nm).
- * During transport on the loading area of a vehicle, tie down the vibration plate using the lugs (17).

Transport to work site /Recommendations on compaction

3.2 Recommendations on compaction

3.2.1 Ground conditions

The max. compaction depth depends on several factors relating to the ground condition, such as moisture, grain distribution etc, it is therefore not possible to specify exact values.

Recommendation: In each case determine the max. compaction depth with compaction tests and soil samples.

3.2.2 Compaction on slopes

The following points are to be observed when compacting on sloped surfaces (slopes, embankments):

- * Only approach gradients from the bottom (a gradient which can be easily overcome upwards, can also be compacted downwards without any risk).
- * The operator must never stand in the direction of descent.
- * The max. gradient of 25° must not be exceeded.



A tilt in excess of this angle could lead to a stopping of the engine due to the automatic low oil shut-off system. A restarting of the engine can only take place after the valve lever at the oil filter housing has been actuated once.

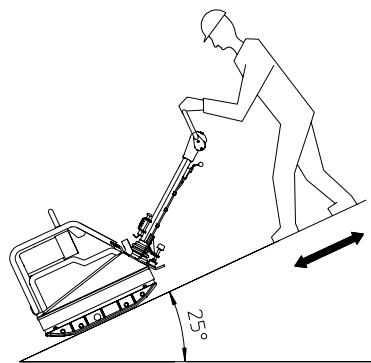

Right !

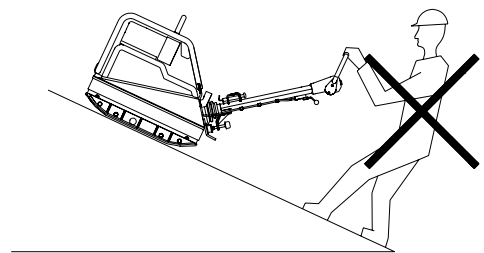

Wrong!

4. Operation



Warning

Improper use can result in injury or serious material damage.

- * Read and follow all the safety instructions at the beginning of this operator's manual, see chapter *Safety information*.

4.1 Starting

4.1.1 Starting requirements:

Engine oil:

Check the oil level with the dipstick (19). Add oil (see *Technical data*) through the filler neck (21) as needed.



The machine must be level and the engine stopped before proceeding with the oil level check.

Fuel:

When pouring diesel fuel into the fuel nozzle (20), maintain absolute cleanliness. Impurities in the fuel can cause breakdowns in the injection system and premature clogging of the fuel filter.



Only refuel the machine when it's engine is stopped.

Never refuel the machine close to open flames or ignitable sparks and do not smoke.

Only use pure, clean fuel and clean filling vessels.

Do not spill any fuel.

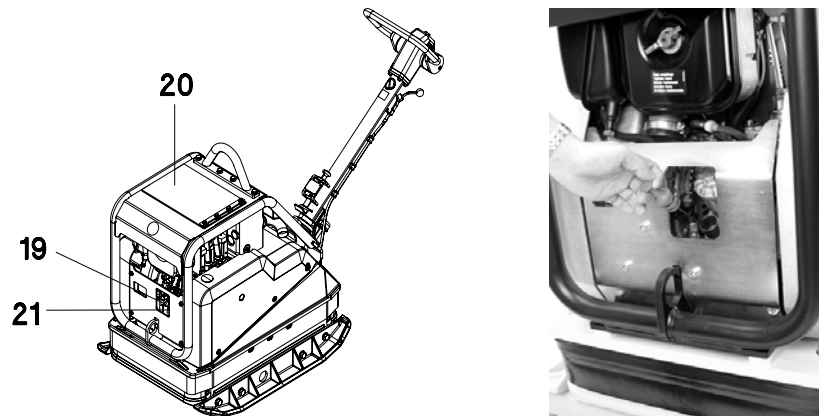

4.2 Mechanical oil pressure control

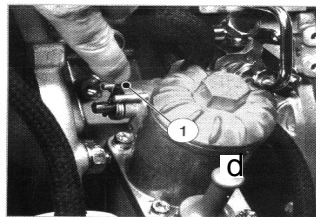

It is necessary to reactivate the mechanical oil pressure control in the following cases:

- * after the initial filling - first filling - of the fuel tank or if the tank has run dry.
- * in the case of an automatic engine stop due to an inefficient engine oil supply.
- * after freeing the engine when in presence of extremely low temperatures.

1. Fill up fuel tank.
2. Check engine oil level.
3. To activate depress hand lever „d“ for approx. 5 seconds.
4. Check to see that the engine does not leak.
5. Start engine.

Check oil level every 8 to 15 operating hours in spite of the mechanical oil pressure control.



Warning*

Danger of poisoning by exhaust fumes!

Exhaust fumes contain toxic carbon monoxide that can lead to unconsciousness or death.

- * Always switch off the engine during maintenance work!

- * Before starting the engine always make sure that nobody is in the danger area of the vibratory plate and also check to see if all the safety devices are installed.

- * Never use starter sprays to start the engine.

Operation

4.3 Electric start

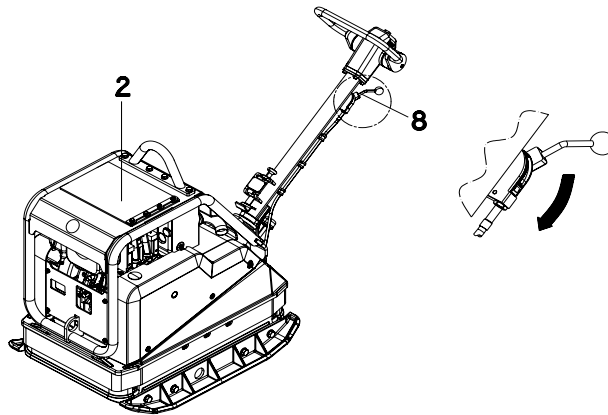

1. Turn the throttle control lever (8) clockwise into load position 1/2 - 3/4.
2. Leave decompression lever (2) in the position „e“.

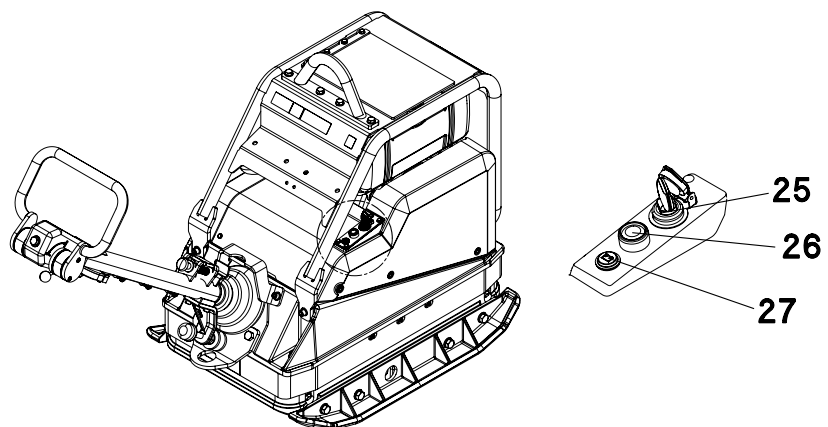
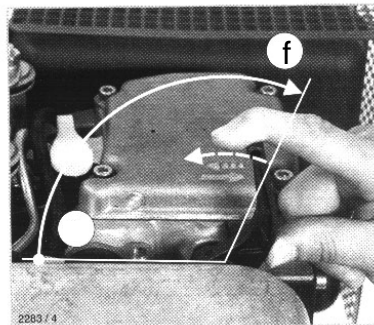

3. Put the ignition key into ignition switch (25) and turn it clockwise into operating position (the charge control lamp (27) lights up and the buzzer will be heard). Press in and hold the starter (26) until the engine has started.



Wait until the engine stops before repeating the starting procedure.

4. The charge control lamp (27) must turn off immediately after the engine has started running and the acoustic alarm has stopped.

Stop the engine immediately in case of eventual irregularities, then locate the fault and repair it.



The machine will start vibrating as soon as the engine starts revving up.

Note: Do not activate automatic decompression lever while the engine is running.

5. Bring the engine up to maximum rpm's and then check the air filter's service indicator (also see chapter on „Maintenance“); clean the dry-type air filter if necessary.

Operation

4.4 Starting the engine with the safety starting crank

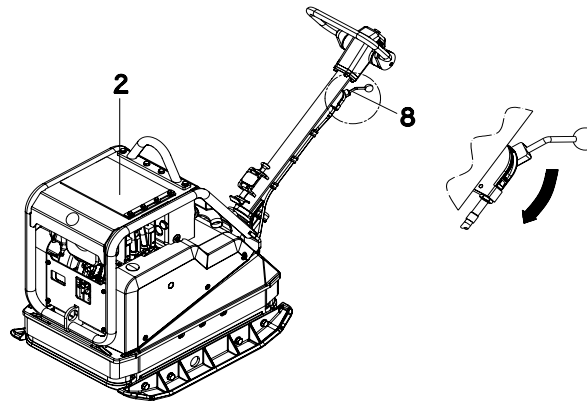

1. Turn the throttle control lever to the load position 1/2 - 3/4.
2. Turn the decompression lever (2) all the way to „f“. At this point automatic decompression lever engages with an audible click, and the engine is ready to start.

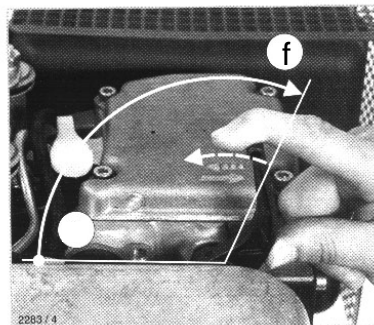

3. Put the ignition key into ignition switch (25) and turn it clockwise into operating position (the charge control lamp (27) lights up and the buzzer will be heard).
4. Check to see that the safety starting crank is in good shape and clean! Broken handle pipes, worn cranking bolts, etc. must be replaced! Lightly grease the gliding area located between the safety starting crank and the guide bush (protective casing).



- * Stand sideways to the engine.
- * Always grasp the handle pipe (h) with both hands.

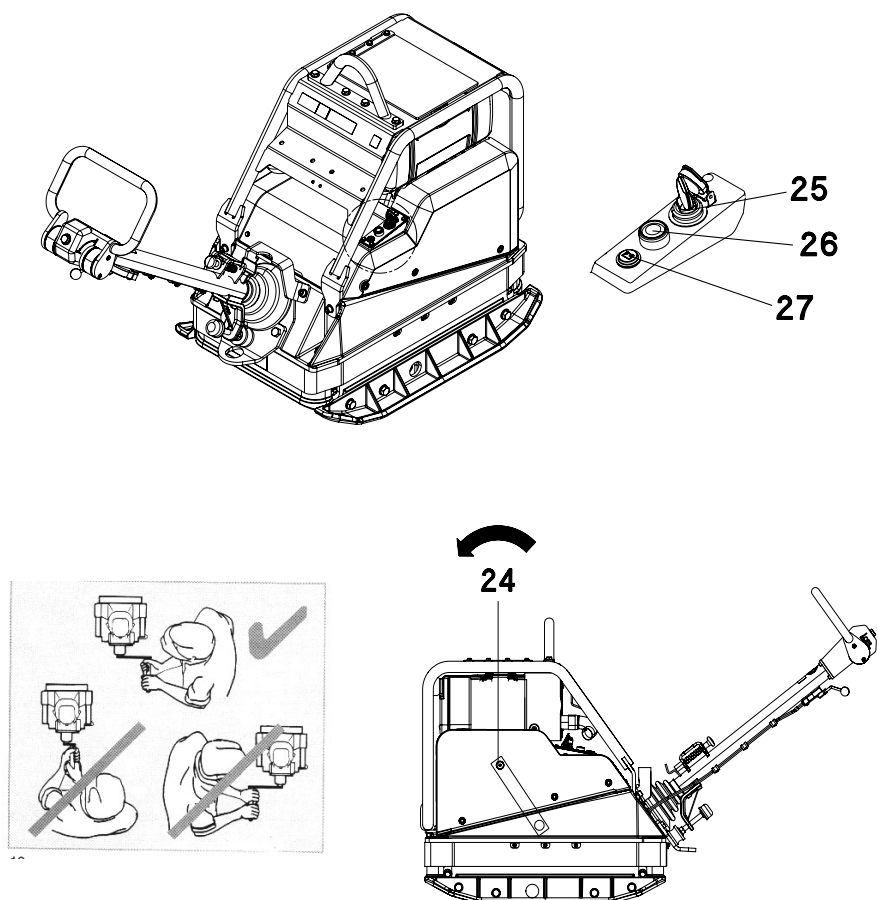

- * Slowly turn the safety starting crank counter-clockwise until the ratchet engages. Then start turning the handle with force and with ever increasing speed. The highest possible turning speed must have been reached when the decompression lever reaches position "e" (compression).

Pull the safety start crank out of the protective hood once the engine has started.



The friction (non-positive) connection between engine and safety starting crank must be guaranteed by a firm grip on the handle pipe and rapid turning of the crank and must not be interrupted under any circumstances during the starting operation.

The connection between the crank web (g) and the crank claw will be released if - due to a hesitant turning of the handle - a return kick should take place during the starting operation.

Operation

- * Let loose of the safety starting crank immediately and stop the engine if it should start turning in the wrong direction (smoke coming from the air filter) after a back kick.



Wait until the engine stops before repeating the starting procedure.

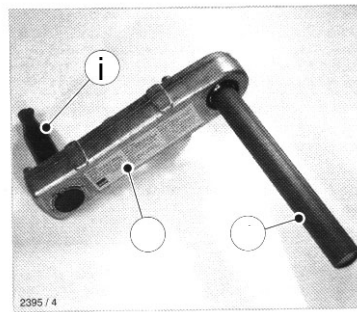

5. The charge control lamp (27) must turn off immediately after the engine has started running and the acoustic alarm has stopped.

Stop the engine immediately in case of eventual irregularities, then locate the fault and repair it.



The machine will start vibrating as soon as the engine starts revving up.

Note: Do not activate automatic decompression lever while the engine is running.

6. Bring the engine up to maximum rpm's and then check the air filter's service indicator (also see chapter on „Maintenance“); clean the dry-type air filter if necessary.

4.5 Starting in cold weather

Always free the engine if the temperature is less than $-5\text{ }^{\circ}\text{C}$ ($23\text{ }^{\circ}\text{F}$).

1. Push the throttle lever (8) to the full throttle position.

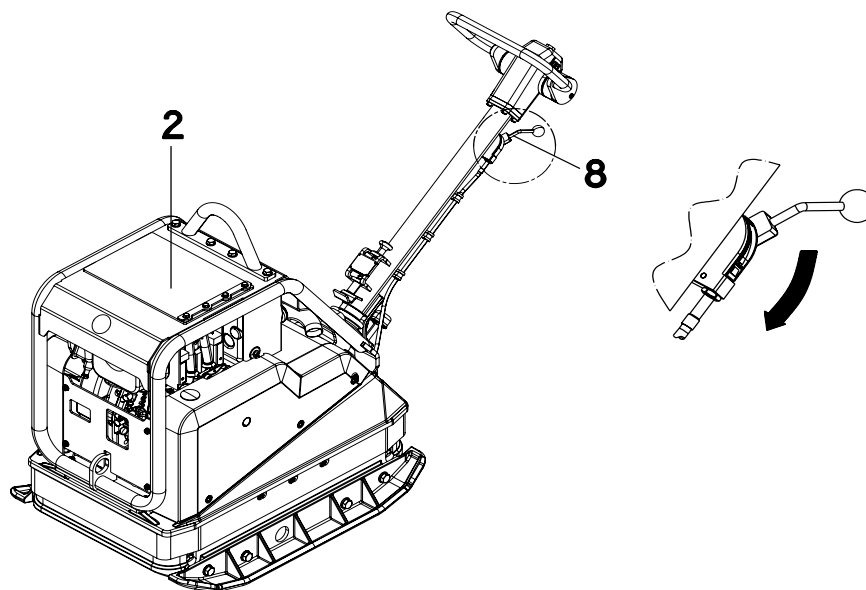

2. Turn decompression lever to any position in front of starting position „f“.
3. Crank the engine counter-clockwise with the safety start crank (24) as long as necessary until cranking becomes easier (10 to 20 crank turns).
4. Press pin „d“ in for approx. 5 seconds.

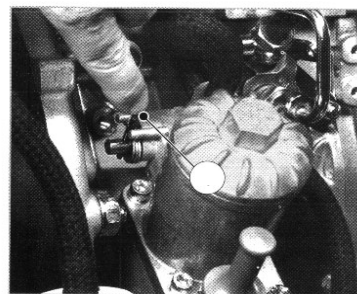
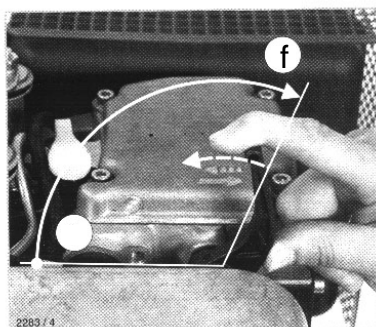

Operation

5. Clean the area around the dosing device and then pull off the cover.

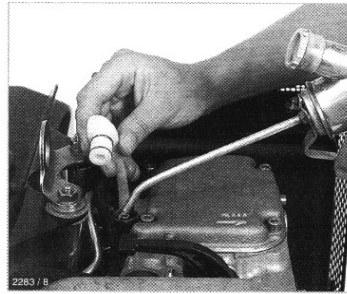

6. Fill the housing to the upper edge with low viscosity oil. Replace cover and press down with force. Exactly two successive fillings are required.
7. Turn the decompression lever all the way to „f“.
8. Then start the engine immediately with the electric starter or by using the safety start crank.

4.6 Starting with external battery etc.

4.6.1 Essential requirements for battery jumper cable:

- * Cable cross-section must be at least 16 mm². (2.5 sq. inches).
- * Clamps must be completely insulated with plastic.



Only connect 12 Volt batteries. The on-board battery will explode if connected to a 24 Volt truck battery!

The use of starter sprays is absolutely forbidden!

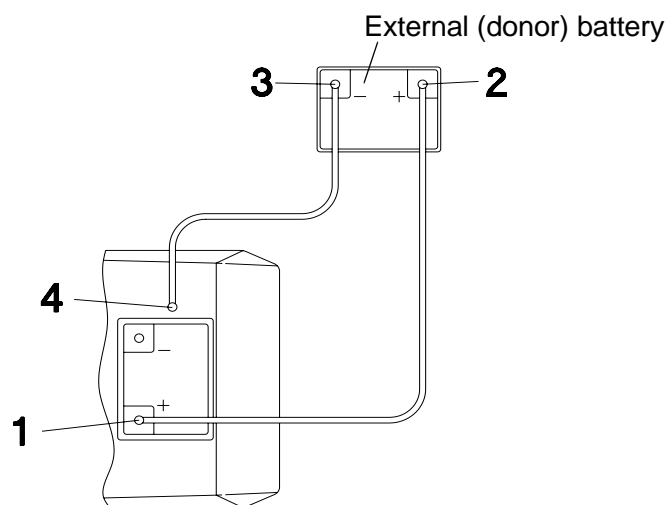

4.6.2 Pay close attention to the following connection sequence when jump-starting with an external battery:

1. Connect the red jumper cable with the help of a clamp to the positive pole (1) of the discharged battery.
2. Connect the other clamp of the red jumper cable to the plus pole (2) of the external (donor) battery.
3. Connect the black jumper cable with the help of a clamp to the negative pole (3) of the external battery.
4. Connect the other clamp of the black jumper cable to a grounding point of the machine (4), e.g. to the engine block.

4.6.3 Connect the black jumper cable to the negative pole (3) of the external battery.

4.6.4 Disconnect the clamps in reverse order; first remove the black jumper cable, then the red one.

Operation

4.7 Forward and reverse motion

The engine speed can be infinitely varied on the throttle control lever.

The direction of travel is determined with the shift lever (6).

Depending on the position of the shift lever (6), the vibration plate compacts in forward direction, at standstill or in reverse direction.

The forward and reverse speeds can be varied by selecting intermediate positions of the shift lever (6) or the machine can be employed for particularly intensive compaction at standstill.

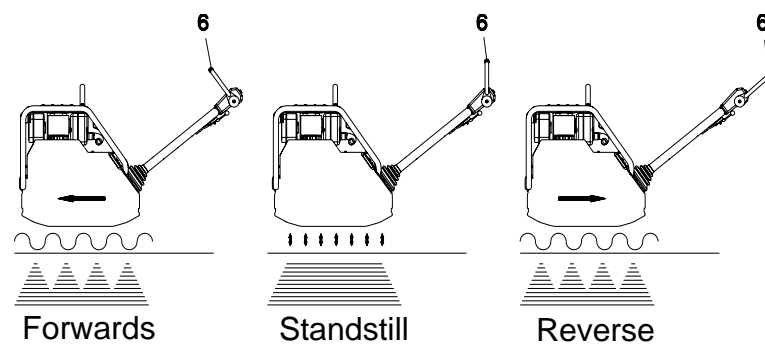

4.8 Compaction without extension plates

If the vibration plates is used without extension plates, screw set of protective screws (8 pes) into the threaded boreholes situated in the lower mass, in order to avoid threads from being damaged.

4.9 Stopping the engine



Never switch off the engine with the automatic decompression (2) as this inevitably results in damage to the valve drive and decompression mechanism.

1. Move the throttle control lever (8) to the stop.

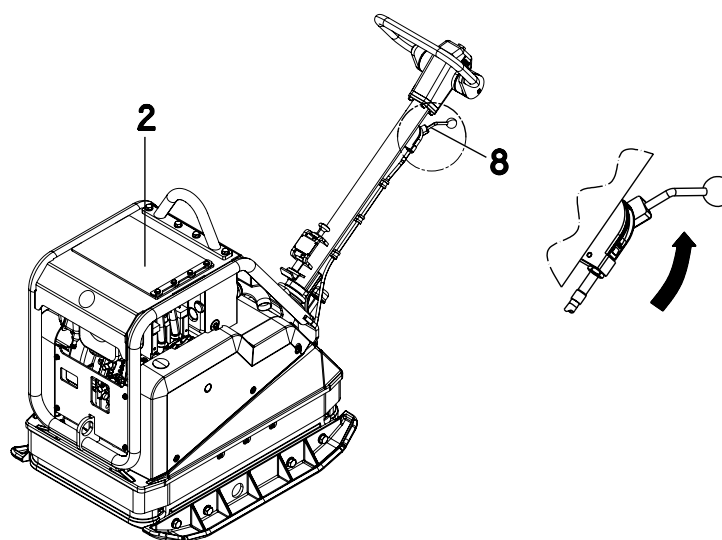

2. Turn the ignition key to the stop position and then pull it out once the engine has stopped. The control lamp will extinguish and the acoustic alarm will turn off.

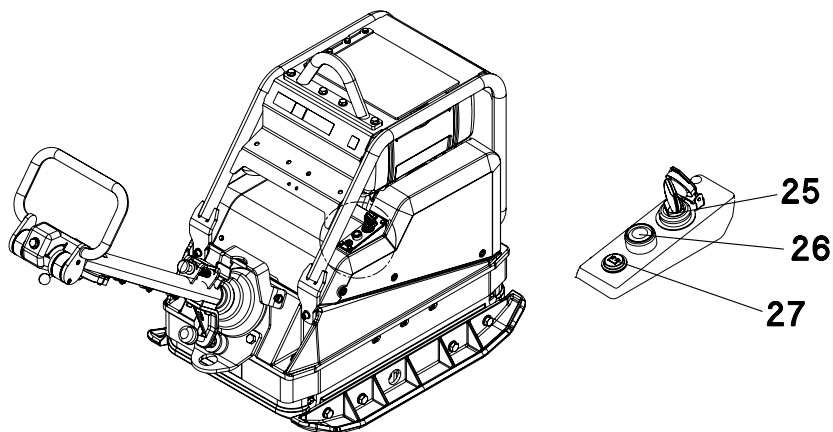

Maintenance

5. Maintenance



Warning*

Danger of poisoning by exhaust fumes!

Exhaust fumes contain toxic carbon monoxide that can lead to unconsciousness or death.

* Always switch off the engine during maintenance work!

5.1 Maintenance schedule

Component	Maintenance work	Maintenance interval
Drive engine	First oil change and filter.	approx. 8 hours after initial start-up
Machine cpl.	Run a visual check to see that everything is complete and undamaged.	daily
Air filter	Check area around combustion air intake and also air filter service indicator.	
Drive engine	Check oil level, if nec. top up oil.	
Centre pole height setting, transport lock	Regrease.	weekly
Fuel tank	Check water separator.	monthly
V-belt	Check V-belt, if. nec. replace.	
Protective frame	Check attachment screws for tight fit.	
Central lifting point		
Tow-bar head	Check oil level, top up if necessary.	
Exciter	Oil change.	every 250 h, or latest every 6 months
Drive engine	Oil change, change oil filter. Keep cooling fins free of dirt, clean dry. Retighten all accessible screw connections.	every 250 h
Battery	Check acid level, if nec. top up with distilled water.	
Fuel filter	Change filter.	every 500 h
Air filter	Replace filter insert.	
Fuel injector	Clean, adjust if necessary, repair or replace.	every 1500 h
Injector valve	Clean, adjust or replace if necessary.	every 3000 h

5.2 Engine oil and oil filter

5.2.1 Check oil level:

- * Remove dirt from the oil dip stick area. Check oil level on oil dipstick (19).



Place the machine in an horizontal (level) position and stop the engine before checking the oil level.

- * If the oil (see *Technical Data*) level is too low, top up with Fuchs oil through the filler nozzle.
- * Pay attention to the max. level mark on the dip stick!



5.2.2 Replacing oil and oil filter:

Note

The work area should be covered with a waterproof sheet to protect the floor (protection of the environment).

1. Let engine warm up.
2. Take off the front cover plate.
3. Remove the oil hose from the support (spanner opening 19) and then hang the hose into an appropriate container.

Danger of scalding by hot oil!



Collect the used oil and dispose of it according to local regulations.

4. Let the oil drain completely. Lift the back end of the machine if necessary.

Maintenance

5. Replace oil filter.

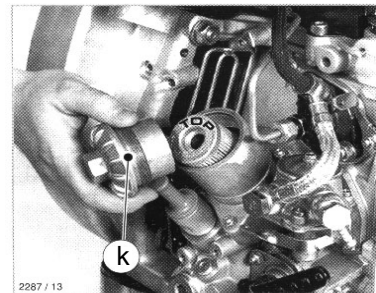

6. Clean filter insert carefully to avoid bending the screen netting.

Wipe off screw plug or blow out with compressed air.

Watch out for the "TOP" marking on the oil filter!



7. Check and, if necessary, replace O-ring „k“.

8. Moisten thread and O-ring of the screwed sealing plug with a lubricant.

9. Fasten the oil hose to the support.

10. Fill up with engine oil until the max. marking of the dip stick is reached.

11. Check the oil level again after a short engine test run and top up if necessary.

12. Be sure to check that the screwed sealing plug does not leak.

13. Fasten the front cover plate.

5.3 Air filter

5.3.1 Air filter inspection:

- * Check and, if necessary, remove coarse dirt accumulation such as leaves, dust deposits etc. from air admission holes.
- * Examine and, if necessary, clean dust outlet (l) openings of cyclone prefilter.
- * Air filter service indicator: Start engine and push throttle to full rpm's for a few seconds.

The filter system must be cleaned if the bellows contracts and covers the green ring (m). Check the bellows often per day when working in extremely dusty conditions.

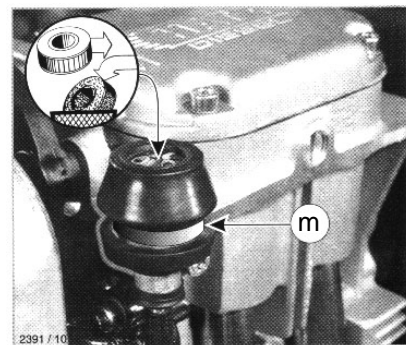

Note

The air cleaner must be cleaned every day if conditions are adverse, dry, and dusty.

Do not clean with compressed air.

5.3.2 Air filter maintenance:

1. Loosen wing (thumb) screw (o) and carefully remove with cover (p). One turn of the cover (p) by 90° towards the right makes removing easier.
2. Carefully remove filter element (r).
3. Check conditions and cleanliness of valve plate (u).

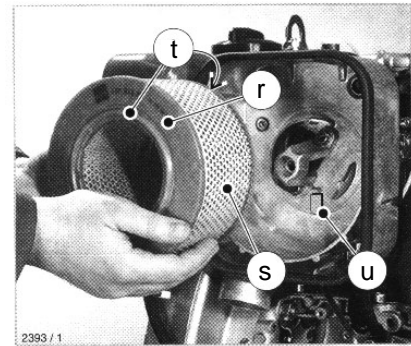
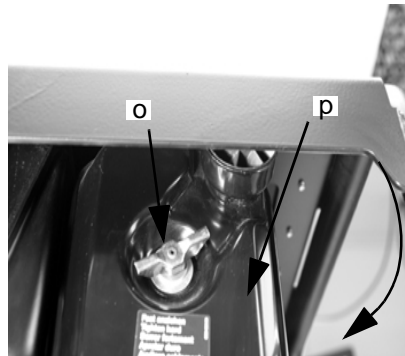

4. Knock the dry dirt out of the filter element.



Do not clean the filter element with compressed air to avoid causing damages.

Note: Check the filter insert for cracks or other damages while holding it against a light or when illuminating it with a lamp.

Do not reuse the filter element if you have determine any kind of damages in the area of the filtering paper (s) or, as the case may be, in the area of the sealing lip (t).

5. Replace the filter element if the maintenance plan requires it.

6. Follow the disassembly procedure in reverse order to refit the filter.



Caution

Operating the engine without air cleaner can cause rapid engine wear.

- * Do not run the engine without an air cleaner.

5.4 Fuel system

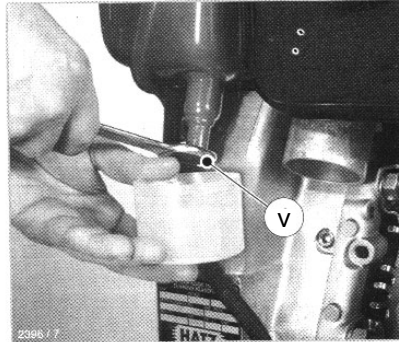

Do not work close to an open fire and do not smoke when working on the fuel system.

5.4.1 Water separator inspection:

- * Turn hex screw „v“ 2 - 3 turns to detach.
- * Collect the emerging drops in a transparent container. First water and then fuel drops will emerge, as water is specifically heavier than diesel fuel. A clear separating line will make this easily recognizable.
- * Turn the hex screw „v“ back in once only clear fuel emerges.

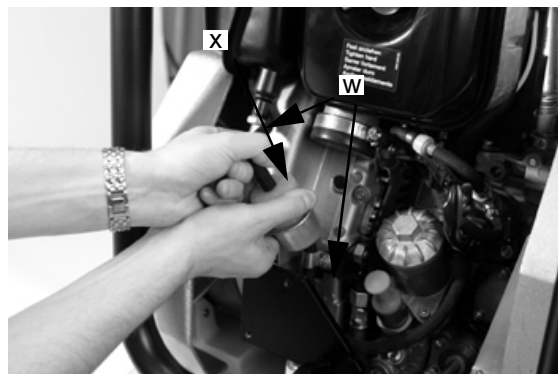

5.4.2 Fuel filter replacement:

- * Place an appropriate container under the filter to catch any emerging

Maintenance

fuel.

- * Close fuel supply line.
- * Pull fuel line „w“ off from both sides of the fuel filter „x“ and then put in a new filter.

Important:

Pay attention to cleanliness and avoid letting any dirt into the fuel line.

- * Always replace fuel filter. Pay attention to the flow direction - look for the arrows.
- * Allow fuel to flow.
- * After a short test run make sure that fuel filter and line do not leak.

5.4.3 Screwed connections control:

Make sure all accessible screwed connections are correctly tightened and in good shape.



Do not retighten cylinder head screws!

The adjusting screws for the speed governor and at the injection system have been provided with a safety lacquer; do not retighten nor reset them.

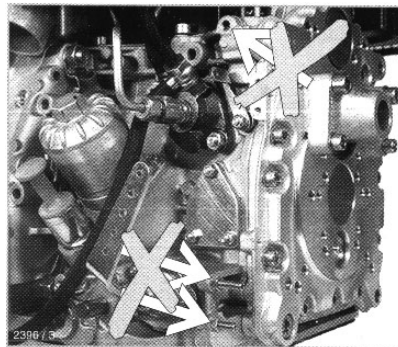

5.5 Battery

5.5.1 Check acid level:

1. Remove battery cover.
2. Check acid level, if necessary top up with distilled water.
3. Secure battery cover.



Make sure the positive battery terminal cover is correctly in place before proceeding to install the battery cover. Check to see that the gas venting hose does not have any kinks!



Protect hands and eyes against the acid!

Note: Only replace defective batteries with original Wacker batteries. Standard batteries are not suitable for the high vibration loads.

4. When changing the battery:

- * Removal: First disconnect negative, then positive terminal of battery.
- * Assembly: First connect positive, then negative terminal of battery.

When using starting sprays etc., see chapter operation.

Maintenance

5.6 Hydraulic control

5.6.1 Check oil level

1. Move centre pole into vertical position.
2. Open filler bore (1).
3. Oil level must coincide with marking (a), top up with hydraulic fluid if necessary (see Technical Data).
4. Close filler bore..

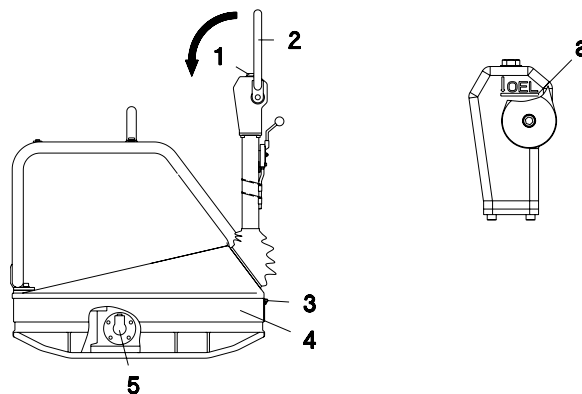

5.6.2 Venting hydraulic control

1. Remove apron (4) by undoing the screws (3).
2. Move centre pole into vertical position, move shift lever (2) right into the reverse position, open filler bore.
3. Loosen connecting screw (5).
4. Slowly push the shift lever into forward motion direction until hydraulic oil emerges bubblefree at the connection screw.
5. Tighten connecting screw, mount apron.
6. If necessary, top up with, seal filler bore.

5.7 Exciter

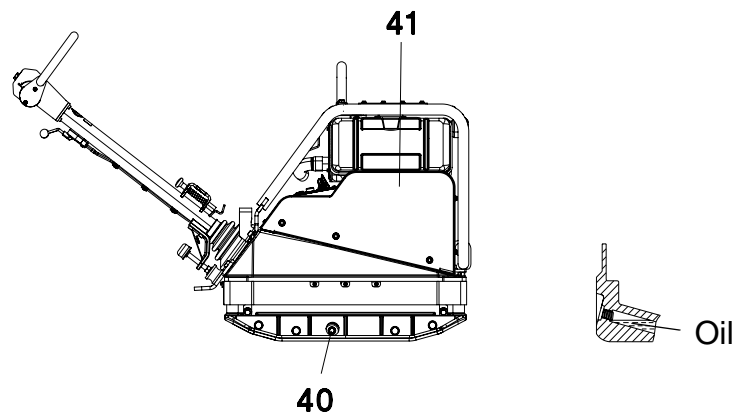

5.7.1 Check oil level:

1. Position vibration plate horizontally.
2. Open filler bore (40).
3. The oil level must reach the start of the thread of the filler bore (40).
4. If necessary, pour in oil (see *Technical Data*) through filler bore (40) (use funnel 0,75 l).
5. Close filler bore (40). (torque setting = 100 Nm)

Maintenance

5.7.2 Changing the oil:

1. Remove extension plates if necessary.
2. Open filler bore (40).



Warning

Danger through overturning.

If the machine overturns, it can cause severe injury such as crushing. Only use suitable and tested hoisting gear and lifting tackle of sufficient lifting capacity.

Place the machine in a stable position.

3. Tilt vibration plate and keep it tilted until the oil has run out.
4. Place vibration plate in horizontal position.

Note

Avoid spilling oil. Remove any spilled oil immediately.

5. Pour in oil (see *Technical Data*) through the filler bore (40).
6. Close filler bore (40). (torque setting = 100 Nm)
7. Mount extension plates if necessary.

Do not pour in too much oil!



5.8 Exciter V-belt

It is not necessary to retighten the V-belt owing to the use of the automatic centrifugal clutch.

Should the V-belt width fall below 15,5 mm the V-belt must be replaced.

5.8.1 Changing the exciter V-belt:

1. Remove belt guard (41).
2. Undo screw (42).
3. Remove button (43), belleville spring (44), seal (45) and front segment of the V-belt pulley (10).
4. Change exciter V-belt (12).
5. Assemble the components in reverse order; make sure that the coloured marking on the pin coincides with the marking on the V-belt pulley (10).



Do not oil or grease clutch components (will damage the graphite bushes).

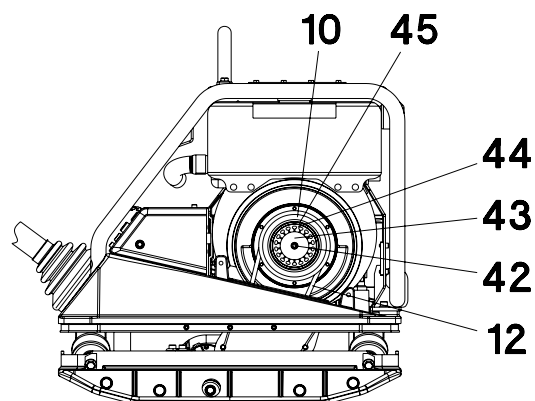

Faults

6. Faults

6.1 Forward speed too low

Cause	Remedy
To little hydraulic oil in the centre pole head.	Top up hydraulic oil.
Air in hydraulic control.	Bleed system.

6.2 Reverse speed too low

Cause	Remedy
Too much hydraulic oil in centre pole head.	Correct oil level in accordance with mark.

6.3 No reverse motion

Cause	Remedy
Mechanical fault.	Contact Wacker Neuson service dept.

6.4 Loss of hydraulic oil

Cause	Remedy
Leaks, hydraulic hose defective.	Contact Wacker Neuson service dept.

6.5 The charge control lamp will not extinguish and/or the buzzer will not stop buzzing

Cause	Remedy
Dynamo defective.	Contact Wacker Neuson service dept.
Control unit defective.	Replace control unit (on rear of the dynamo).

6.6 Engine does not start

Cause	Remedy
Ignition lock defective.	Change defective parts.
Starter defective.	
Start knob defective.	
Battery flat.	Charge battery.
Lack of lubricating oil.	Fill up with oil and actuate valve lever at oil filter housing once.

3 Disposal

3.1 Disposal of batteries

For customers in EU countries

This device contains one or more batteries or rechargeable batteries (hereafter referred to as "batteries"). This battery is subject to the European Directive 2006/66/EC on (waste) batteries, as well as the corresponding national legislation. The battery directive outlines the procedure for handling batteries across the EU.



The battery is labelled with the symbol of a crossed out dustbin shown here. Below this symbol is a list of all the harmful substances it contains, namely "Pb" for lead, "Cd" for cadmium and "Hg" for mercury.

Batteries may not be disposed of with normal household waste. As the end user, only dispose of waste batteries via the manufacturer, the dealer or special collection points for this purpose (legal obligation to return), which is free of charge. Dealers and manufacturers are obliged to accept the return of the batteries and to use them properly or to dispose of them as hazardous waste (legal obligation to accept). You can also return any used batteries you obtained from us free of charge. If you do not return the batteries to one of our branches personally, make sure you have paid sufficient postage for its return. Please also note any information in the sales contract and the general terms and conditions from the point of sales.

The proper disposal of the battery prevents the occurrence of any negative effects on people or the environment, follows the specific procedures for handling harmful substances and enables valuable raw materials to be recycled.

For customers in non-EU countries

This device contains one or more batteries or rechargeable batteries (hereafter referred to as "batteries"). The proper disposal of the battery prevents the occurrence of any negative effects on people or the environment, follows the specific procedures for handling harmful substances and enables valuable raw materials to be recycled. Therefore, we recommend that this battery is disposed of in a separate, environmentally-friendly waste collection and not with normal household waste. In some cases, national legislation stipulates the separate disposal of batteries. Please ensure you dispose of this battery in accordance with the valid regulations in your country.



EC Declaration of Conformity

Manufacturer

Wacker Neuson SE
Preußenstraße 41, 80809 München

Product

Type		DPU 6555
Product type		Vibrating plate
Item no.		0610354, 0610355, 0610356
Installed power output	kW	9,9
Measured sound power level	dB(A)	108
Guaranteed sound power level	dB(A)	109

Conformity assessment procedure acc. to 2000/14/EC, Appendix VIII, 2005/88/EC at following test center:

VDE Prüf- und Zertifizierungsinstitut, Merianstraße 28, 63069 Offenbach/Main

Guidelines and standards

This is to certify that this product meets and complies with the relevant regulations and requirements of the following guidelines and standards:

2006/42/EC,

2000/14/EC, 2005/88/EC

Authorized person for technical documents: Axel Häret

Munich, 08.03.2010

Franz Beierlein
Head of product management

Dr. Michael Fischer
Head of Research and Development

