

CROMMELINS™ DRIVE UNITS

OPERATION & INSTRUCTION MANUAL

Thank you for your selection of a CROMMELINS™ Drive Unit.
This Operation Manual explains its use, installation, checking and maintenance.
We highly recommend that you retain this manual for ready reference regarding
proper handling of the CROMMELINS™ Drive Unit.



Spare Parts & Service

Phone: 1300 554 524

Freecall Fax: 1800 636 281

spareparts@crommelins.com.au

www.crommelins.com.au



Thank you very much for purchasing a CROMMELINS™ DRIVE UNIT.
This manual covers operation and maintenance of the CROMMELINS™ DRIVE UNIT.
This CROMMELINS™ DRIVE UNIT can be used in the agricultural, mining, construction, hire industries and general use.

Please take a moment to familiarise yourself with the proper operation and maintenance procedures in order to maximise the safe and efficient use of this product.

Keep this owner’s manual at hand, so that you can refer to it at anytime.
Due to constant efforts to improve our products, certain procedures and specifications are subject to change without notice.

When ordering spare parts please have handy your products model number and serial number. Record these numbers in the boxes below for future reference.

MODEL NO.

--	--	--	--	--	--	--	--	--	--	--	--	--	--	--	--	--	--	--	--

SERIAL NO.

--	--	--	--	--	--	--	--	--	--	--	--	--	--	--	--	--	--	--	--

CONTENTS

Introduction & Contents	2
Safety & Components Diagram	3
Connecting Drive Pump or Vibrator Shaft	4
Maintenance & Transportation	5
Storage & Maintenance	6
Specification Chart	7
Trouble Shooting Guide	8
Drive Unit Parts List	9
Product Safety Assessment Sheet	10-11

SAFETY

This manual contains important information on how to use the following drive unit models DU53, DU53D, DU53DS41, DU53BF, DU53EX17 and DU73 properly and safely. Please read through this manual before you attempt to operate the machine.

Ensure safe operation, this drive unit is designed to give safe and dependable service if operated according to the instructions.

- Always make a pre-operation inspection before starting the engine. (For more information read engine operational manual)
- Do not place flammable objects near the unit.
- Children and pets must keep away from the area of operation at all times.
- Never allow anyone to operate the unit without proper instructions.
- Must know how to stop the engine quickly and understand the operation of all controls.
- Be careful with the operating place and ventilation, avoid operating the machine in a closed room, tunnel, or other badly ventilated places, since its exhaust contains deadly poisonous carbon monoxide. If the machine is unavoidably operated in such a place, discharge the exhaust outside the room by a suitable means.
- Mufflers and other hot parts are dangerous. Do not touch them with hands or any other body parts.
- Observe the following cautions when transporting. Close fuel tank cap securely and close fuel tap tightly during transportation. Drain petrol or diesel from fuel tank before transporting over a long distance or on rough roads.
- Stop engine without fail before replenishing fuel tank. Never replenish fuel while the engine is running or remains hot otherwise spilled or evaporated fuel is liable to catch fire from the engine spark or muffler heat. Wipe off spilled fuel before starting engine.

To prevent injury wear the following protective items: Gloves, hard hat, work boots, ear plugs, safety glasses and any other protective items required by job conditions.



COMPONENTS (MOST MODELS)

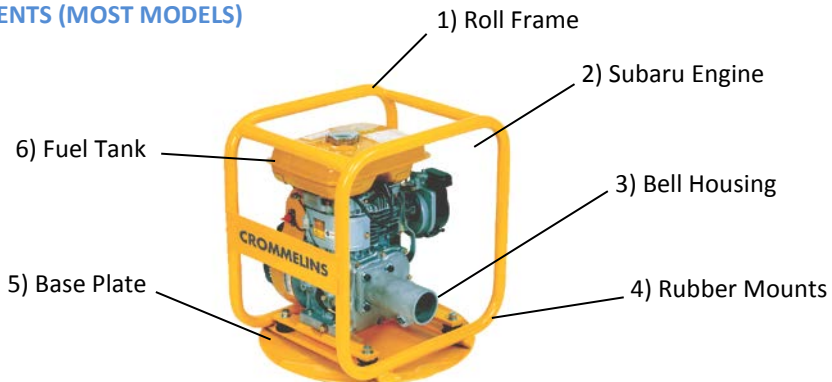

CONNECTING DRIVE PUMP OR VIBRATOR SHAFT

- Ensure that the connecting end is securely engaged and properly latched into the drive unit.

BEFORE STARTING

- Check the engine in accordance with operation manual for engine.
- Check fuel and engine oil.
- Check bolts and screws for tightness and make sure all bolts and screws are securely tightened. Loose bolts and screws may cause damage to the unit.

STARTING

- Open fuel tap.
- Set the speed control lever to the starting position.
- Close the choke lever of the carburettor (leave the choke lever half-open position during warming up the engine – petrol engine only).
- Pull the recoil starter strongly.
- After the engine has started open the choke lever fully and warm up the engine for 2-3 minutes in the low speed position.

OPERATING

- Take care not to over-speed the flexible shaft or damage could result.
- Engine speed is set to 3100RPM which is correct for vibrator shafts. Operating in excess of this speed may cause damage to vibrator shaft.

STOPPING THE MACHINE

- Operate the machine 1-2 minutes with the throttle lever setting back to the low speed position.
- Turn the ignition switch to “OFF” for petrol unit. Press STOP lever for diesel unit.
- Close the fuel cock.
- After the engine has cooled, it is highly recommended to wipe off the machine and inspect oil seals for any unusual leakage from the engine.
- It is also recommended that a cover be placed over the machine once cooled, to provide protection to the machine as well as the engine.

MAINTENANCE

When assembling, lubricating, or adjusting any part of the machine, make sure to stop the engine and disconnect the spark plug wire. Service the engine according to the engine manufacturer's specifications. Refer to the engine operation and maintenance manual.

Maintenance: Every 8 hours or daily

- Check for loose bolts and nuts, retighten if necessary.
- Check and clean the air filter element, re-lube the element according to engine manufacturer's recommendations. If operating conditions are usually dusty and severe, cleaning of filter elements should be done more frequently.
- Check oil level in crankcase and replenish as necessary.
Recommended engine oil is SAE-30.

Maintenance: Every 450 – 500 hours

FUEL & LUBRICANT

Engine Model	Fuel Tank Capacity	Engine Oil Per Litre	Engine Oil Type	Fuel Type	Spark Plug
EY20D	3.8L	0.6L	SAE30	Petrol	NGK BR6HS
DY272D	3.2L	0.9L	SAE30	Diesel	-
DY272DS	3.2L	0.9L	SAE30	Diesel	-
EX17	3.6L	0.6L	SAE30	Petrol	NGK BR6HS
EH25DU	6.0L	1.0L	SAE30	Petrol	NGK BR6HS

TRANSPORTATION

- Before transportation, confirm that the fuel shut-off valve is closed.
- Be sure to let the engine cool off before transportation.
- When loading and unloading the machine to and from the vehicle, lift the machine with extreme care. The machine is heavy, and must not be lifted single-handedly. Lift the machine by two people holding each side of roll frame.
- Tie the machine firmly to the vehicle during the transportation.

STORAGE

- Make sure that the engine is completely cooled off before storage.
- Clean up oil and dust accumulation on rubber parts.
- Remove flexible drive pump or vibrator shaft before storage.
- Cover the machine and store it in a dry place.
- For long-term storage of petrol unit, remove fuel from the fuel tank. Also remove fuel remained in the fuel line and chamber of the carburettor. To drain fuel from the chamber of the carburettor, remove the drain plug provided at the chamber, and remove fuel.

WARRANTY

Consult the CROMMELINS Machinery warranty leaflet (supplied with your new product) for full details and a list of service dealers for this product, also available online at www.crommelins.com.au.

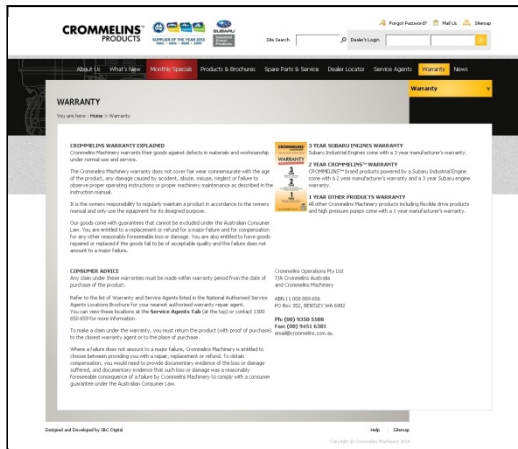

The screenshot shows the 'Warranty' page on the Crommelins website. The page features a navigation menu at the top with options like 'Home', 'Products & Brochure', 'Square Parts & Service', 'Dealer Locator', 'Service Agents', 'Warranty', and 'About'. The main content area is titled 'WARRANTY' and includes a 'CROMMELINS WARRANTY EXPLAINED' section. This section details the warranty terms for various engine types: 3 Year Subaru Engines Warranty, 2 Year CROMMELINS™ brand products warranty, and 1 Year Other Products Warranty. It also includes a 'CUSTOMER ADVICE' section and contact information for Crommelins Pty Ltd. The page footer includes the text 'Designed and Developed by MC Digital' and '© 2014 Crommelins Pty Ltd'.

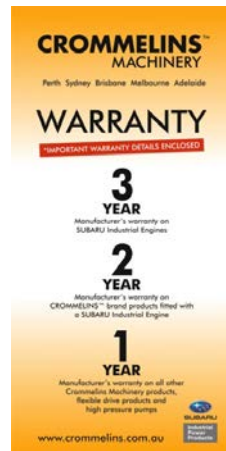

The image shows the cover of the Crommelins Machinery Warranty leaflet. The cover is yellow and black and features the company logo at the top. Below the logo, it reads 'Perth Sydney Brisbane Melbourne Adelaide'. The word 'WARRANTY' is prominently displayed in large, bold letters. Below this, a red banner states 'IMPORTANT WARRANTY DETAILS ENCLOSED'. The cover highlights three warranty periods: '3 YEAR Manufacturer's warranty on SUBARU Industrial Engines', '2 YEAR Manufacturer's warranty on CROMMELINS™ brand products fitted with a SUBARU Industrial Engine', and '1 YEAR Manufacturer's warranty on all other Crommelins Machinery products, flexible drive products and high pressure pumps'. The Subaru logo is visible in the bottom right corner, along with the website address www.crommelins.com.au.

DRIVE UNITS SPECIFICATION CHART

MODEL	DU53	DU53D	DU53DS41
Weight (kg)	32.0	49.0	61.0
Engine Make	Subaru	Subaru	Subaru
Engine	5.0hp EY20	5.4hp DY27	8.5hp DY41
Engine Features	Recoil Start	Recoil Start	Electric Start
Fuel Type	Petrol	Diesel	Diesel
Fuel Tank Capacity	3.8L	3.2L	4.5L
Noise Level db@7m	69.0	74.0	78.0
Manufacturers Warranty	2 yrs	2 yrs	2 yrs
Engine Warranty	3 yrs	3 yrs	3 yrs
Drives Vibrators (upto)	65mm	65mm	75mm
Drives Pumps (upto)	50mm	50mm	75mm
Roll Frame	Heavy Duty	Heavy Duty	Heavy Duty
Sub Frame	Rubber Mounted	Rubber Mounted	Rubber Mounted

MODEL	DU53BF	DU53EX17	DU73
Weight (kg)	31.0	32.0	38.0
Engine Make	Subaru	Subaru	Subaru
Engine	5.0hp EY20	6.0hp EX17	8.5hp EH25
Engine Features	Recoil Start	Recoil Start	Recoil Start
Fuel Type	Petrol	Petrol	Petrol
Fuel Tank Capacity	3.8L	3.8L	6.0L
Noise Level db@7m	69.0	66.0	70.0
Manufacturers Warranty	2 yrs	2 yrs	2 yrs
Engine Warranty	3 yrs	3 yrs	3 yrs
Drives Vibrators (upto)	65mm	65mm	65mm
Drives Pumps (upto)	50mm	50mm	75mm
Roll Frame	Heavy Duty	Heavy Duty	Heavy Duty
Sub Frame	Rubber Mounted	Rubber Mounted	Rubber Mounted

TROUBLE SHOOTING GUIDE

PROBLEM	CAUSE	SOLUTION
Engine won't start	<ol style="list-style-type: none"> 1. Engine switch in OFF position 2. Throttle lever on/off switch in OFF position 3. No fuel in engine 4. Worn, fouled or dirty spark plug 5. Pressure build up in pump 	<ol style="list-style-type: none"> 1. Turn engine switch to ON position 2. Turn throttle lever to ON position 3. Fill fuel tank or turn on fuel supply 4. Replace with factory recommended spark plug 5. Squeeze trigger on spray wand to release pressure in hose line
Units with Oil Alert System	<ol style="list-style-type: none"> 1. Engine not level or engine oil level too low 	<ol style="list-style-type: none"> 1. Place engine on level surface or fill crankcase with oil (refer to engine manufacturers instruction manual)
Engine with low power	<ol style="list-style-type: none"> 1. Throttle control lever not set to full throttle position 2. Partially clogged gun nozzle 	<ol style="list-style-type: none"> 1. Set throttle control lever to full position 2. Clean nozzle of any blockage
Engine runs well at no load but 'bogs' down under full load	<ol style="list-style-type: none"> 1. Engine speed too low 	<ol style="list-style-type: none"> 1. Contact your pressure cleaner dealer
Engine will not start: or starts and runs rough	<ol style="list-style-type: none"> 1. Low oil level 2. Dirty air filter 3. Out of petrol 4. Stale petrol 5. Spark plug wire not connected to spark plug 	<ol style="list-style-type: none"> 1. Fill crankcase to proper level 2. Clean or replace air cleaner 3. Fill fuel tank 4. Drain fuel tank, fill with fresh fuel 5. Connect wire to spark plug

DU53 DRIVE UNIT

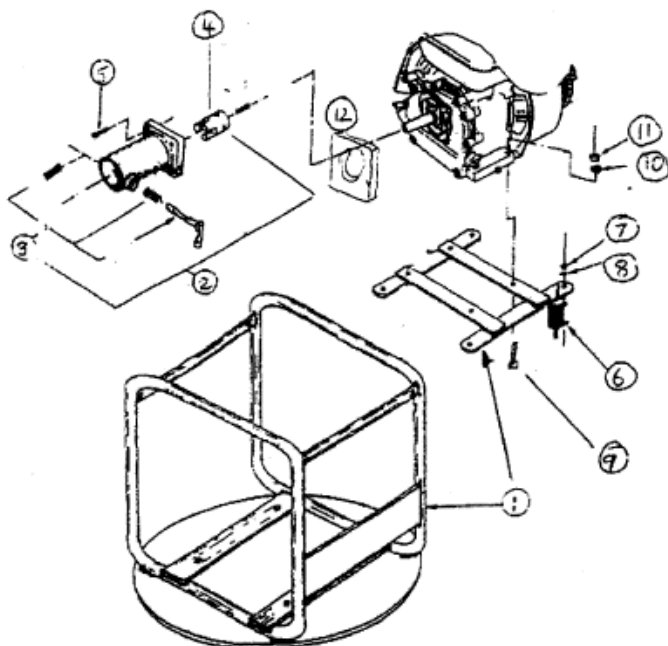

REF	PART NO.	DESC	QTY
1	DU530100	BASE & H-PLATE SET	1
2	DU530200	BELL HOUSING AND DRIVE DOG SE	1
3	> DU530210	LATCH PIN ASSEMBLY	1
4	> DU530320	3 DOG COUPLING 20MM	1
5	8X30SH	SCREWS 8 X30	4
6	4504000500	RUBBER MOUNTS	4
7	3049	HEX ZP NUT 10	8
8	3714	WASHER S10	8
9	8X50	BOLTS	4
10	14408	WASHER 8S	8
11	3048	NUT 8	4
	OPTIONAL PARTS		
4	> DU530310	3 DOG COUPLING 1 "	10
4	> DU530319	3 DOG COUPLING 19mm	10
4	> DU530325	3 DOG COUPLING 25MM	10
12	> DU53W	BELL HOUSING SPACER 8MM (DIESELS)	10



Hire and Rental Industry Association Ltd

Product Safety Assessment Sheet

PLANT INFORMATION

PSA Ref #: 00012

Model No: DU53

Plant Name: CROMMELINS ENGINE DRIVEN DRIVE UNIT DU53

Manufacturer: Crommelins Machinery WA

Manufacturer's Website: www.crommelins.com.au

Web Link for Plant: www.crommelins.com.au

Potential noise level in dB: 95 to less than 100

Required hearing protection class: 3

Mandatory Personal Protective Equipment:



Foot
Protection



Hearing
Protection



Protective
Clothing



CROMMELINSTM
MACHINERY

RISK ASSESSMENT INFORMATION

Operator Competency: Plant Licence Not Required

Potential Hazard(s)	Risk Level	Control Measure(s)
Explosion or fire from fuel vapours.	Medium	<ul style="list-style-type: none">• Stop the engine before refuelling. Do not refuel while hot. Avoid spillage of fuel when refuelling. Ensure the fuel cap is properly secured after refuelling. Carry out visual inspection for fuel leaks and repair before operation. Keep flammables away from the engine. Warning label on engine. Do not smoke while operating, servicing or refuelling this machine.
Exposure to ultraviolet radiation if working outdoors.	Medium	<ul style="list-style-type: none">• Wear sunscreen, hat, long sleeves and long trousers.
Inhaling exhaust or fuel fumes.	Medium/Low	<ul style="list-style-type: none">• Operate only in a well ventilated area. Do not operate in a confined space. Avoid breathing petrol fumes. Avoid skin contact with petrol. Warning label on engine.
Contact with hot parts of the engine.	Medium/Low	<ul style="list-style-type: none">• The muffler is fitted with a heat shield. Let the engine cool down before attempting any maintenance. Avoid contact with hot components. Warning label on engine.
Manual handling hazard.	Medium/Low	<ul style="list-style-type: none">• Use two people to lift. Do not attempt to lift by one person. Weight 32 kgs.

Hearing damage from excessive noise. Medium/Low

Coming into contact with moving parts. Low

Do not use on inclines of more than 20 degrees

- Hearing protection with a rating of 20db must be worn.
- All moving parts are shielded. Do not remove guards or covers.
- Ensure the equipment is operated on a stable, level surface. If equipment is operated on a slope, engine seizure may occur due to improper lubrication, even with max. oil level and functioning oil protection system. Fuel spillage may also occur.

Customer Identified Hazard(s)

Key Operating Instructions

Use unleaded fuel only.

To START, turn on the fuel tap by moving the lever to the down position.

Ensure the stop switch on the engine is in the ON position.

For cold starting close the choke lever.

Start the engine by pulling the recoil rope with the throttle in low speed position.

As the engine warms up return the choke to the open position.

To commence operation open the throttle to the desired speed.

Ensure that the connecting end is securely engaged and properly latched into the drive unit.

Take care not to overspeed the flexible shaft or damage could result.

To STOP, return the throttle to low speed, turn the stop switch to OFF and turn off the fuel tap.

Please refer to the User Guide and Operator's Manual for Operating Instructions

The Safety Information on this assessment has been developed for the Hire and Rental Industry to assist in the safe operation of this equipment.

This information contains general information only and should not be relied upon as a substitute for professional advice, which the user should seek before operating.

Once printed this is an uncontrolled copy.

