

Kubota

- U.S.A. : **KUBOTA TRACTOR CORPORATION**
3401 Del Amo Blvd., Torrance, CA 90503, U.S.A.
Telephone : (310)370-3370
- Western Division : 1175 S. Guild Av., Lodi, CA 95240
Telephone : (209)334-9910
- Central Division : 14855 FAA Blvd., Fort Worth, TX 76155
Telephone : (817)571-0900
- Northern Division : 6300 at One Kubota Way, Groveport, OH 43125
Telephone : (614)835-1100
- Southeast Division : 1025 Northbrook Parkway, Suwanee, GA 30024
Telephone : (770)995-8855
- Canada : **KUBOTA CANADA LTD.**
5900 14th Avenue, Markham, Ontario, L3S 4K4, Canada
Telephone : (905)294-7477
- France : **KUBOTA EUROPE S.A.S**
19-25, Rue Jules Vercey, Z.I. BP88, 95101 Argenteuil Cedex, France
Telephone : (33)1-3426-3434
- Italy : **KUBOTA EUROPE S.A.S Italy Branch**
Via Grandi, 29 20068 Peschiera Borrome (MI) Italy
Telephone : (39)02-51650377
- Germany : **KUBOTA BAUMASCHINEN GmbH**
Steinhauser str, 100, 66482 Zweibrücken Rheinlandpfalz Germany
Telephone : (49)6332-4870100
- U.K. : **KUBOTA (U.K.) LTD.**
Dormer Road, Thame, Oxfordshire, OX9 3UN, U.K.
Telephone : (44)1844-214500
- Australia : **KUBOTA TRACTOR AUSTRALIA PTY LTD.**
25-29 Permas Way, Truganina, VIC 3029, Australia
Telephone : (61)-3-9394-4400
- Malaysia : **SIME KUBOTA SDN. BHD.**
No.3 Jalan Sepadu 25/123 Taman Perindustrian Axis,
Seksyen 25, 40400 Shah Alam, Selangor Darul Ehsan Malaysia
Telephone : (60)3-736-1388
- Philippines : **KUBOTA PHILIPPINES, INC.**
155 Panay Avenue, South Triangle Homes, 1103 Quezon City, Philippines
Telephone : (63)2-9201071
- Taiwan : **SHIN TAIWAN AGRICULTURAL MACHINERY CO., LTD.**
16, Fengping 2nd Rd, Taliiao Shiang Kaohsiung 83107, Taiwan R.O.C.
Telephone : (886)7-702-2333
- Indonesia : **P.T. KUBOTA INDONESIA**
Jalan Setyabudi 279, Semarang, Indonesia
Telephone : (62)-24-7472849
- Thailand : **SIAM KUBOTA CORPORATION CO., LTD.**
101/19-24 Moo 20, Navanakorn Industrial Estate, Tambon Khlongnueng, Amphur Khlongluang,
Pathumthani 12120, THAILAND
Telephone : (66)2-909-0300
- Japan : **KUBOTA Corporation**
Farm & Industrial Machinery International Operations Headquarters
2-47, Shikitsuhigashi 1-chome, Naniwa-ku, Osaka, Japan 556-8601

English (Australia)
Code No. RD358-8131-6

OPERATOR'S MANUAL

KUBOTA EXCAVATOR

MODELS **KX**057-4 • **U**55-4

Interim
T4
TIER

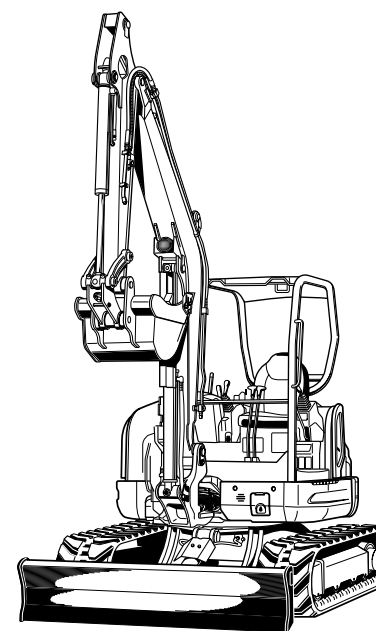

1BAAABYAP0860

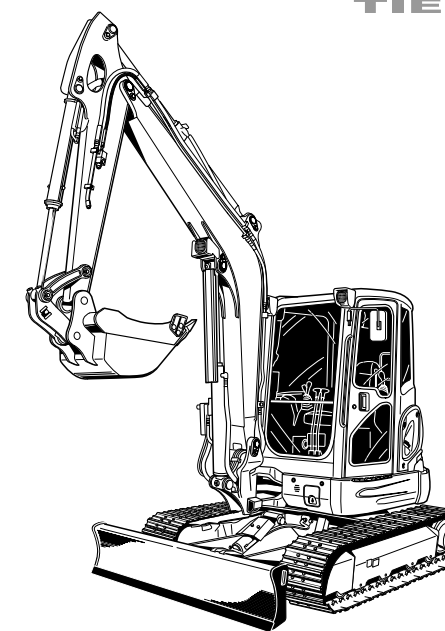

1BAAABYAP0870

K
X
0
5
7
-
4
•
U
5
5
-
4



































READ AND SAVE THIS MANUAL

ABBREVIATION LIST

Abbreviations	Definitions
API	American Petroleum Institute
ASTM	American Society for Testing and Materials, USA
CECE	Committee for European Construction Equipment
DIN	German Institute for Standards, Federal Republic of Germany
EN	European Standard
FOPS	Falling Object Protective Structures
FRONT	"Front" means the front view towards the boom and dozer
Hi	High speed
ISO	International Standardization Organization
JIS	Japanese Industrial Standard
L	Volume (Liter)
L/min	Liter per minute
Lo	Low speed
MIL	Military Standards
rpm	Revolutions per minute
ROPS	Roll-Over Protective Structures
SAE	Society of Automotive Engineers, USA
TPSS	Two Pattern Selection System
AI	Auto Idle

GENERAL SYMBOLS

The instruments and operation elements have been marked with a series of symbols in order to simplify the operation of your excavator. These symbols are listed below with the respective descriptions.

	Safety alert Symbol		Boom swing (Left)
	Warning lamp "Fuel level too low"		Boom swing (Right)
	System lamp		Dozer raise
	Warning lamp "Engine Oil pressure "		Dozer lower
	Warning lamp "Battery charge"		Operation direction of control lever
	Warning lamp "Auto Idle (AI) Lamp"		Operation direction of control lever
	Indicator lamp "Glow"		Read operator's manual
	Working light switch		Lock
	Horn		Unlock
	Wiper/Washer switch		Engine stop control lamp
	Diesel		
	Hydraulic fluid		
	Gear oil		
	Grease		
	Fast		
	Slow		
	Excavator - Overhead view, movement toward the front		
	Excavator - Overhead view, movement toward the rear		
	Boom raise		
	Boom lower		
	Arm out		
	Arm in		
	Bucket crowd		
	Bucket dump		

FOREWORD

You are now the proud owner of a KUBOTA excavator. This excavator is a product of KUBOTA quality engineering and manufacturing. It is made of excellent materials and under rigid quality control systems. It will give you long, satisfactory service. To obtain the best use of your excavator, please read this manual carefully. It will help you become familiar with the operation of the excavator and contains many helpful hints about excavator maintenance. It is KUBOTA's policy to utilize as quickly as possible every advance in our research. The immediate use of new techniques in the manufacture of products may cause sections of this manual to become outdated. KUBOTA distributors and dealers will have the most up-to-date information. Please do not hesitate to consult with them.



SAFETY FIRST

This symbol, the industry's "Safety Alert Symbol", is used throughout this manual and on labels on the machine itself to warn of the possibility of personal injury. Read these instructions carefully. It is essential that you read the instructions and safety regulations before you attempt to assemble or use this unit.



DANGER : Indicates an imminently hazardous situation which, if not avoided, will result in death or serious injury.



WARNING : Indicates a potentially hazardous situation which, if not avoided, could result in death or serious injury.



CAUTION : Indicates a potentially hazardous situation which, if not avoided, may result in minor or moderate injury.

IMPORTANT : Indicates that equipment or property damage could result if instructions are not followed.

NOTE : Gives helpful information.

CONTENTS

▲SAFE OPERATION	▲-1
DEALER SERVICE.....	1
TECHNICAL DATA.....	2
DESCRIPTION OF MACHINE PARTS.....	4
INSTRUMENT PANEL AND CONTROL ELEMENTS.....	5
CHECKS BEFORE START	7
DAILY CHECKS.....	7
CHECKING THE DEVICES	7
Starter Switch	7
Display Selector Switch	8
LCD Display for Normal Operation	8
Warning Lamp	11
LCD Display for Warning	11
Setting the Clock.....	13
Reordering the year/month/day and Changing the AM/PM System to the 24-hour One	14
Log Record	15
Periodic Check.....	16
If All the Check Points are not Displayed at a Glance on a Single Screen.....	16
When the Check-up is Completed	18
Horn Switch	18
Working Light Switch	18
AUX Port Flow Rate Limit Switch	18
Auto Idle Switch.....	19
Throttle Potentiometer	19
Travel Speed Switch.....	19
CAB TYPE MACHINES	20
Wiper/Washer Switch	20
Interior Lamp.....	20
Cab Light Switch.....	21
Heater Switch	21
Opening/Closing of CAB Door	21
Opening/Closing of Front CAB Window.....	22
Opening/Closing of Side CAB Window	22
Emergency Hammer.....	22
AIR CONDITIONER	23
Air Flow.....	23
Air Control Vent	24
Control Panel.....	24
Operation	24
HANDLING THE SAFETY DEVICES.....	24
Pilot Control Lock Lever.....	24
OPERATION OF THE ENGINE.....	25
STARTING THE ENGINE	25
STARTING THE ENGINE UNDER COLD CONDITIONS.....	26

STARTING WITH AN AUXILIARY BATTERY	27
Observe Following Guidelines when Starting with an Auxiliary Battery.....	27
CHECK POINTS AFTER STARTING THE ENGINE	28
STOPPING THE ENGINE.....	28
Engine Stop Button.....	28
Precautions in case of Overheat.....	28
EXCAVATOR OPERATION	29
RUNNING-IN OF THE NEW EXCAVATOR.....	29
Do not Work with Full Engine Rpm's or Full Loads during the First 50 Working Hours..	29
Oil Change in the Run-in Stage	29
Adjusting the Operator's Seat.....	29
Seat Belt	30
STARTING	30
Pilot Control Lock Lever.....	30
DRIVING	31
Drive Levers(Right,Left).....	32
TURNS.....	32
Pivot Turn	32
Spin Turn	33
UP AND DOWNHILL DRIVING.....	34
PARKING ON A SLOPE	34
OPERATION OF THE DOZER	34
TWO PATTERN SELECTION SYSTEM(TPSS)	35
Pattern Change.....	35
OPERATION OF THE BOOM.....	36
OPERATION OF THE ARM.....	36
OPERATION OF THE BUCKET	37
UNIT SWING AND BOOM SWING OPERATION.....	37
Unit Swing Operation.....	37
Boom Swing Operation.....	37
AUXILIARY PORT OPERATION	38
Selecting the Action Modes	38
AUX Port Handling Procedure	39
Setting the Maximum Flow Volume	41
HOW TO RELEASE PRESSURE TRAPPED IN THE HYDRAULIC SYSTEM.....	46
1-way or 2-way CIRCUIT SELECTION VALVE OPERATION	47
AUTO IDLE (AI) OPERATION	48
IMPORTANT INFORMATION ON EXCAVATOR OPERATION	48
TRANSPORTING THE EXCAVATOR ON A VEHICLE.....	49
LIFTING OF THE EXCAVATOR.....	51
MAINTENANCE.....	53
MAINTENANCE INTERVALS	53
OPENING AND CLOSING OF COVERS.....	56
Opening/Closing of the Engine Hood	56
Opening/Closing of the Side Cover	56
Where to store the Tool	57
Where to store the Grease Gun.....	57
Where to keep Operator's Manual.....	58

Cup Holder.....	58
DAILY CHECKS.....	58
Checking Coolant Level.....	58
Checking Fuel Level.....	59
Checking Engine Oil Level.....	59
Checking Hydraulic Oil Level.....	60
Checking V-belt.....	60
Checking Radiator and Oil Cooler.....	61
Checking Washer Liquid.....	62
Cleaning Pre-Cleaner.....	62
Checking and Cleaning Engine and Electrical Wiring.....	62
Greasing Boom Swing Fulcrum.....	62
Washing Whole Machine.....	62
Greasing Front Attachments (without Bucket Pin and Boom Swing Fulcrum).....	63
Greasing Bucket Pin and Bucket Link Pin.....	63
REGULAR CHECKS AND MAINTENANCE WORK.....	64
EVERY 50 SERVICE HOURS.....	64
Draining Fuel Tank.....	64
Draining Water Separator.....	64
Battery.....	65
Battery Charging.....	66
Greasing Swing Bearing Teeth.....	66
EVERY 200 SERVICE HOURS.....	67
Adjusting V-belt Tension.....	67
Checking Radiator Hoses and Clamps.....	68
Inspection and Cleaning Air Filter Element.....	68
Air Filter Maintenance.....	69
Greasing Swing Ball Bearing.....	69
Checking Fuel Line and Intake Air Line.....	70
AIR CONDITIONER.....	70
Cleaning Air Filter.....	70
Checking Air-Conditioner Condenser.....	71
EVERY 250 SERVICE HOURS.....	71
Changing Engine Oil(First Engine Oil Change after 50 Service Hours).....	71
Replacing Engine Oil Filter.....	72
EVERY 500 SERVICE HOURS.....	72
Drive unit Oil Change(First Oil Change of the 50 hours).....	72
Replacing Fuel Filter Cartridge.....	73
Replacing Breather Filter.....	73
EVERY 1000 SERVICE HOURS.....	73
Replacing the Hydraulic Pilot Filter Element.....	73
Replacing Hydraulic Return Filter Element.....	74
Hydraulic Oil Change (Including Replacing of the Suction Filter in the Hydraulic Tank).....	74
Hydraulic Oil Check with Hydraulic Hammers.....	75
EVERY 1000 SERVICE HOURS OR ONCE A YEAR.....	76
Replacing Air Filter Element.....	76
EVERY 1500 SERVICE HOURS.....	76
Checking Fuel Injection Nozzle(Injection Pressure).....	76
EVERY 2000 SERVICE HOURS.....	76
Changing Front Idler and Track Roller Oil.....	76
Checking the Alternator and Starter Motor.....	76

EVERY 3000 SERVICE HOURS	76
Checking Injection Pump	76
ANNUAL SERVICING	76
Electrical Wiring and Fuses	76
Checking the Electrical Circuit	76
Checking Air-Conditioner Pipes and Hoses	76
BIENNIAL SERVICING	77
Replacing Air-Conditioner Pipes and Hoses	77
Replacement of Radiator Hoses	77
Changing Radiator Coolant	77
Replacing Fuel Hose	78
Replacing Intake Air line	79
SERVICING AS REQUIRED	79
Checking Amount of Refrigerant (gas)	79
OTHER ADJUSTMENTS AND REPLACEMENTS	80
PURGING OF THE FUEL SYSTEM	80
ADJUSTMENT OF TRACKS	80
Special Information when Using Rubber Tracks	81
CHANGING THE BUCKET	82
FUSES	82
Replacing Fuses	82
Fuse Capacities and Circuits	83
Auxiliary Electric	84
Slow Blow Fuse	84
TROUBLESHOOTING	85
OPERATION UNDER COLD WEATHER CONDITIONS	87
PREPARATION FOR OPERATION IN COLD WEATHER	87
PROCEDURE AFTER DONE WORK	87
LONG STORAGE	88
RECOMMENDED OILS	90
APPENDICES	91
MAIN DIMENSIONS	91
LIFTING CAPACITY	92
LIST OF SCREENS	101
LIST OF NORMAL SCREENS	101
NAVIGATION LIST OF SCREENS	102



SAFE OPERATION

Careful operation is your best insurance against an accident.

Read and understand this manual carefully, before operating the excavator.

Every user, however experienced, should carefully read and understand this manual and those of the attachments and accessories before operating the excavator. The owner is obliged to inform all operators of these instructions in detail.

Keep this manual in the storage location. (See "Where to keep Operator's Manual" in "MAINTENANCE" section.)

1. BEFORE OPERATION

1. Know your equipment and its limitations. Read and understand this entire manual before attempting to start and operate the excavator.
2. Obey the danger, warning and caution labels on the machine.
3. For your safety, a ROPS/FOPS (Roll-Over Protective Structure, Falling Objects Protective Structure.) with a seat belt is installed by KUBOTA. Always use the seat belt when the machine is equipped with a ROPS/FOPS as this combination will reduce the risk of serious injury or death, should the excavator be upset or falling objects occur.
Do not modify any structural members of the ROPS/FOPS by welding, drilling, bending, grinding or cutting, as this may weaken the structure. If any component is damaged, replace it. Do not attempt repairs. If the ROPS/FOPS is loosened or removed for any reason, make sure all parts are reinstalled correctly. Tighten mounting bolts to proper torque.
4. ROPS/FOPS structure complies with ISO 3471, ISO 3449 and OSHA regulations.

5. The seat belt must be inspected regularly and replaced if frayed or damaged.

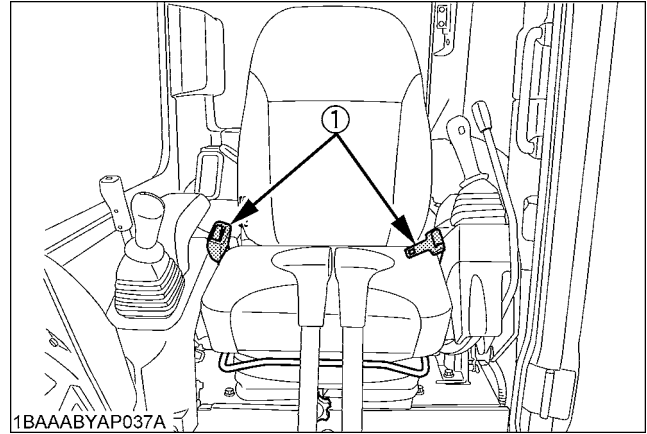

(1) Seat belt

6. Always sit in the operator's seat when starting engine or operating levers or controls.
7. Study control lever pattern A and pattern B. Then choose the one which is most familiar. Familiarize yourself with the pattern selected by operating the unit slowly and at low engine speed.
 - Engage the lever lock to prevent accidental pattern change.

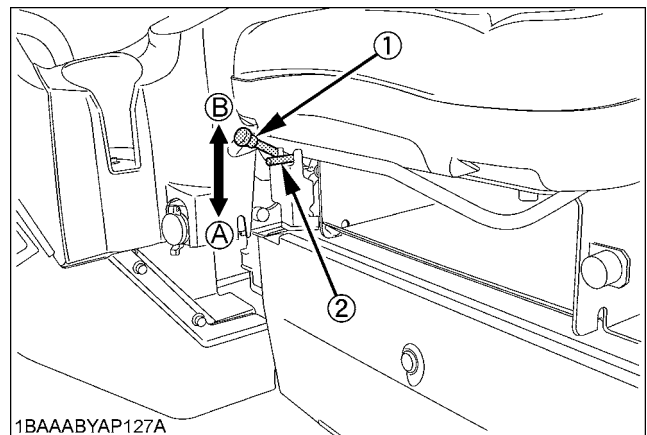

(1) Pattern selector lever (A) "Pattern A"
(Two Pattern Selection System:TPSS) (B) "Pattern B"
(2) Lever lock

8. Do not operate the excavator while under the influence of alcohol, medication, controlled substances or while fatigued.

▲-2 SAFE OPERATION

9. Check the surroundings carefully before using the excavator or when attachments are being attached.
- Pay attention to the overhead clearance with electric wires.

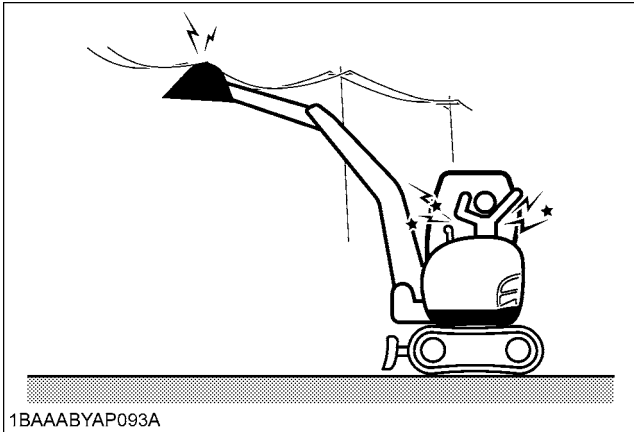

- Check for pipes and buried cables before digging.
- Check for hidden holes, obstacles, soft underground, and overhangs.

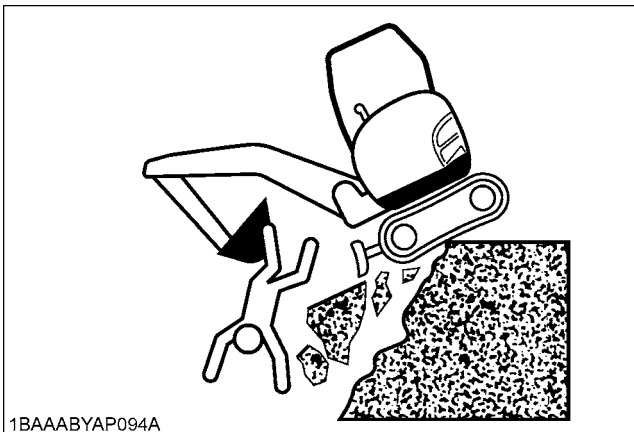

- Do not allow any persons within the working range of the excavator during operation.
 - Check local regulations before digging and call diggers hotline before working, www.diggershotline.com or 811 (WI) and www.ne-diggers.com or 1-800-331-5666 (NE).
10. Do not allow anyone to use the excavator until they have been advised of the work to be performed and they have indicated that they have read and understood the operator's manual.

11. Do not wear baggy, torn or oversized clothing when working with the excavator as such clothing can get caught in rotating parts or control elements which can cause accidents or injuries. Wear adequate safety clothing, e.g. safety helmet, safety shoes, eye protection, ear protection, working gloves, etc., as necessary and as prescribed by law or statutes.

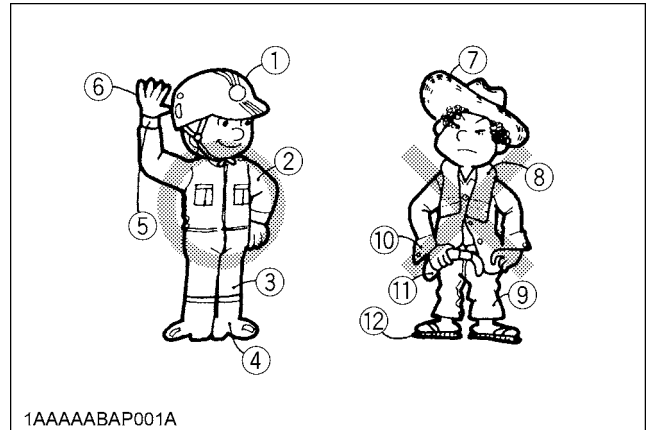

- | | |
|---------------------------|-------------------------------|
| (1) Helmet | (7) Straw hat |
| (2) Clothing fit for work | (8) Towel |
| (3) Tight seams | (9) Baggy trousers |
| (4) Good grip footwear | (10) Loose cuffs of the shirt |
| (5) Well fitting cuffs | (11) Baggy shirt |
| (6) Working gloves | (12) Rubber sandals |

12. Do not allow passengers to ride on any part of the excavator at anytime. The operator must remain in the excavator seat during operation.
13. Check levers, pedals and all mechanical parts for correct adjustment and wear. Replace worn or damaged parts immediately. Check nuts and bolts regularly for correct torque.
14. Keep your excavator clean. Heavy soiling, grease, dust and grass can cause fires, accidents or injuries.
15. Use only KUBOTA authorized attachments.
16. Before starting the excavator, be absolutely sure that the excavator has been filled with fuel, lubricated, greased and undergone all necessary maintenance.
17. Do not modify the excavator, as such it could lead to unforeseen safety problems.
18. Do not operate a hydraulic hammer on anything that is above the operator's seat level as objects may fall into the operator station.
19. Make sure attachments, particularly those utilizing quick attach systems, are securely mounted.
20. Install protective guards on the excavator when working in areas where objects may fall or be thrown.

2. OPERATING THE EXCAVATOR

1. Mount and dismount the machine safely. Always face the machine. Always use handrails and available steps and keep yourself well balanced. Do not grab or hold any of the control levers and switches. Do not jump on or off the machine, whether stationary or in motion.
2. Start and control the excavator only from the operator's seat. The driver should not lean out of his seat when the engine is running.
3. Before starting the engine, make sure that the lock levers are in the "Lock" position and all control levers and pedals are in their neutral positions and the seat belt is fastened correctly.
4. Before operating the excavator, make sure that the dozer blade is in front of you. If the levers are activated with the dozer blade at the rear, the tracks will move in the opposite direction of the drive levers.

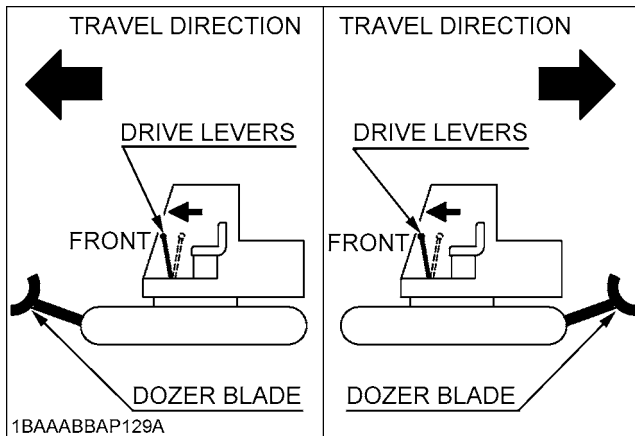

5. Do not operate or idle engine in a non-ventilated area. Carbon monoxide gas is colorless, odorless, and deadly.

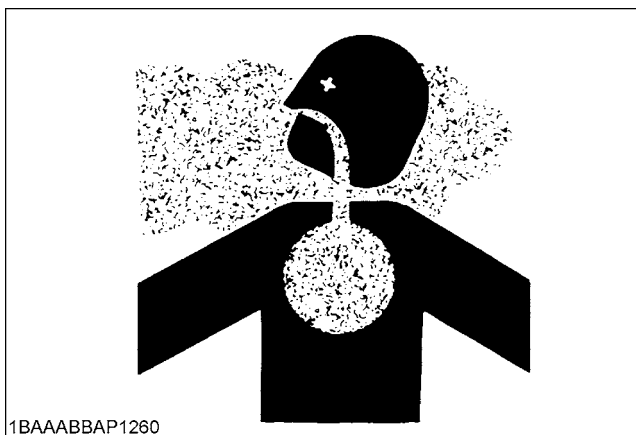

6. Keep all safety equipment and covers in place. Replace damaged or missing safety devices.

7. When operating, keep hands and body inside of the ROPS / FOPS protective envelope. Do not touch or depress the control levers or the pedals from outside the cab while the engine is running.
8. Take precautions against tipping over. Stay away from steep slopes and embankments. Do not swing the bucket downhill. Lower the dozer blade when digging. Keep the bucket as low as possible while driving uphill. Turn slowly on slopes (at reduced speed). Do not place the excavator near the edges of trenches and banks, as the earth can give away due to the weight of the excavator.
ALLOWABLE CLIMBING ANGLE : 36 % (20 deg.)
ALLOWABLE ANGLE CROSS : 27 % (15 deg.)
9. Watch where you are going at all times. Watch for and avoid obstacles. Remain alert for trees, wires and other obstructions.

◆ Safety for children

Tragedy can occur if the operator is not alert to the presence of children. Children generally are attracted to machines and the work they do.

1. Never assume that children will remain where you last saw them.
2. Keep children out of the work area and under the watchful eye of another responsible adult.
3. Be alert and shut your machine down if children enter the work area.
4. Never carry children on your machine. There is not a safe place for them to ride. They may fall off and be run over or interfere with your control of the machine.
5. Never allow children to operate the machine even under adult supervision.
6. Never allow children to play on the machine or on the attachments.
7. Use extra caution when backing up. Look behind and down to make sure the area clear before moving.
8. When parking your machine, if at all possible, park on a firm, flat and level surface; if not, park across a slope. Lower the bucket and dozer to the ground, stop the engine, release pressure in the hydraulic system, place the pilot control lock lever in the locked position, remove the key and lock the cab door (if equipped), before you leave.

3. AFTER OPERATION

Before leaving the machine,

- Park the excavator on a firm, flat and level surface. If this is not possible, park across the slope.
- Lower the attachments and the dozer blade to the ground.
- Stop the engine.
- Release pressure in the hydraulic system.
- Lock all control levers.
- Remove the key.
- Lock the cab door (if equipped)

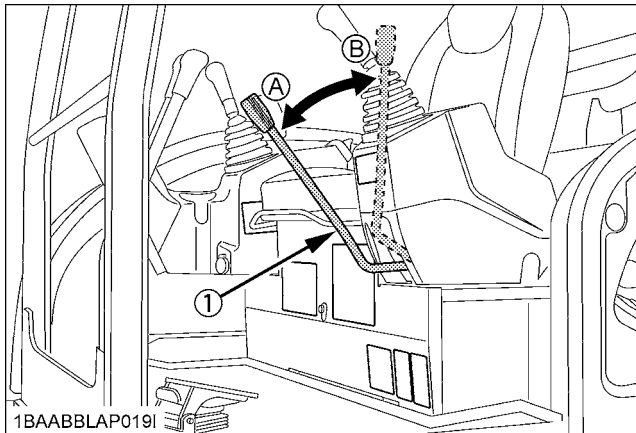
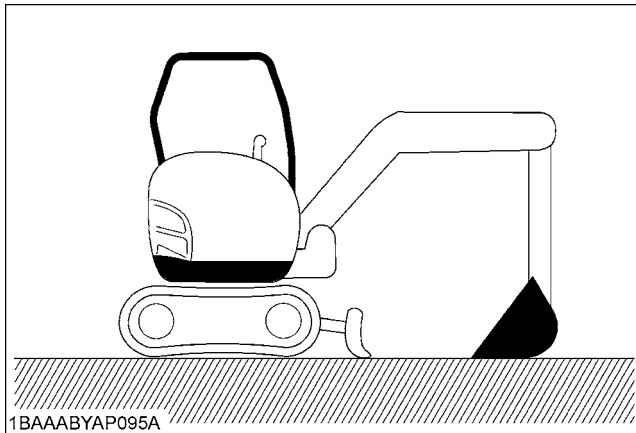

(1) Pilot control lock lever
 (A) "Unlock"
 (B) "Locked"

4. SAFE LOADING AND TRANSPORT OF THE EXCAVATOR

1. Observe all regulations concerning the transport of excavators on public roads.
2. Use adequately long and robust ramps when loading on the machine. (for details see "TRANSPORTING THE EXCAVATOR ON A VEHICLE")
3. Do not change the running direction and to avoid tipping over, do not try to swing the attachment crosswise to the loading ramps.
4. Lower the attachment on the loading bed and release the pressure from the hydraulic system.
 After loading the excavator on the truck, block the tracks with blocks and tie down the excavator at the appropriate locations.

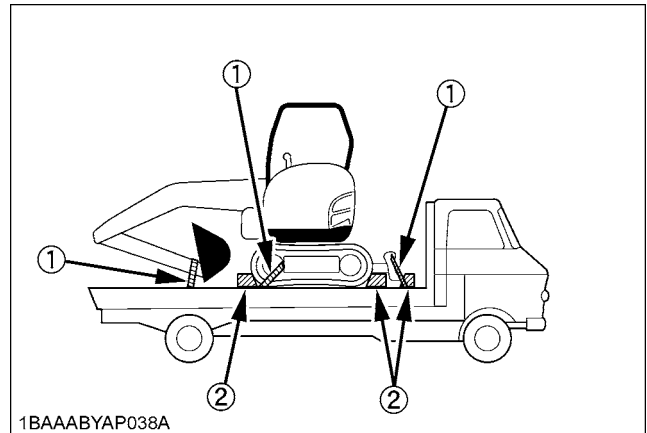

(1) Chain
 (2) Block

5. Avoid abrupt braking of the vehicle with the excavator loaded. Sudden braking cause the excavator to move and may cause a serious accident.
6. When towing the excavator or pulling a load, the load must be less than the strength of the towing line attached to excavator. The towing eye should not be used for tie down or lifting of the machine.

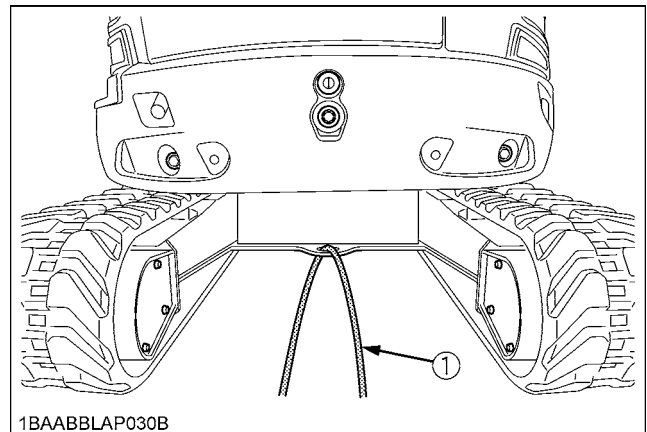

(1) Tow line

Max. drawbar pull at coupling hook	116.9 kN (11920 kgf)
Max. vertical load at coupling hook	12.1 kN (1234 kgf)

7. Do not use the hooks on the roof of CAB for lifting the excavator.

5. MAINTENANCE

Before doing maintenance work on the excavator, place the machine on a firm, flat and level surface, lower the attachments to the ground, stop the engine, release pressure trapped in the hydraulic system, lock all control levers and remove the key. When dismantling hydraulic parts, make sure that the hydraulic oil has cooled down sufficiently to avoid burns.

Start maintenance work carefully, e.g. loosen plug slowly so that oil will not squirt out.

1. Before doing work on the engine, the exhaust system, the radiator and the hydraulics, let the excavator cool down sufficiently.
2. Always turn off the engine when filling the fuel tank. Avoid spilling and over-filling of fuel.
3. Smoking is prohibited while refueling or handling the battery. Keep sparks and fire away from the fuel tank and battery. Flammable gases escape from the battery, especially during charging.
4. Do not use or charge a refillable type battery if the fluid level is below the LOWER (lower limit level) mark. Otherwise, the battery component parts may prematurely deteriorate, which may shorten the battery's service life or cause an explosion. Check the fluid level regularly and add distilled water as required so that the fluid level is between the UPPER and LOWER levels.
5. Read and follow the directions "STARTING WITH AN AUXILIARY BATTERY" in "OPERATION OF THE ENGINE", when starting with an auxiliary battery.
6. Keep a first-aid box and a fire extinguisher at hand at all times.

7. Do not open the radiator cap before the radiator has cooled down sufficiently
First loosen the cap to the first stop and allow the system enough time to release the remaining pressure. Then loosen the cap completely.

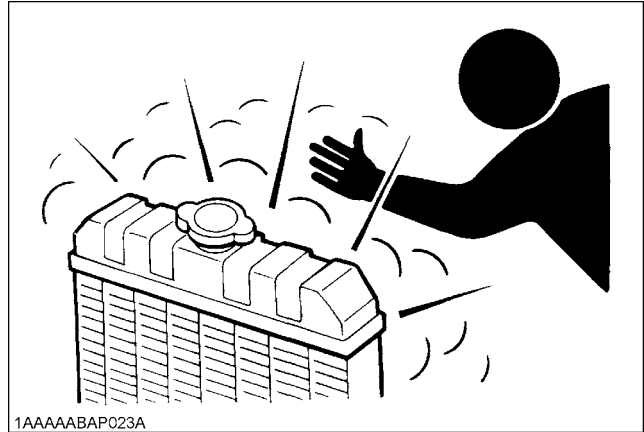

1AAAAABAP023A

8. To avoid short-circuiting the battery, always remove the ground cable first and attach the positive cable first.
9. Oil under high pressure can penetrate the skin and may be harmful to your health if not treated immediately.
10. Leaking hydraulic fluid has enough pressure to penetrate the skin and cause serious injuries. Leakages from pin holes can be totally invisible. Do not use hands for checking for leaks. Always use a piece of wood or cardboard. It is strongly recommended that you use a face mask or eye protection.
Should injuries occur with leaking hydraulic fluid, contact a doctor immediately. This fluid can cause gangrene or serious allergic reactions.

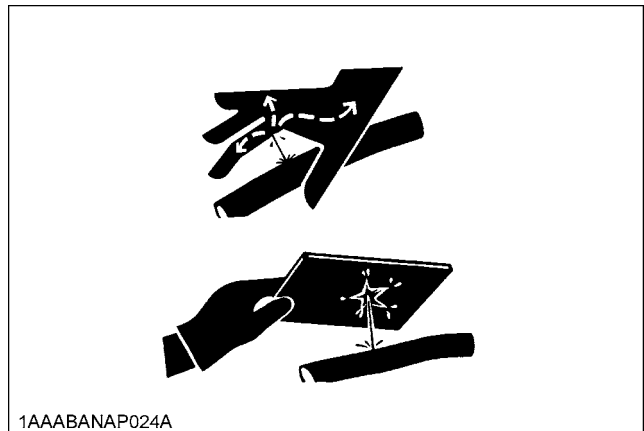

1AAABANAP024A

11. To avoid environmental damage from acid and heavy metals, dispose of the battery appropriately.
12. Observe all laws and regulations concerning the disposal of used oil, coolants, solvents, hydraulic fluids, battery acids and batteries.

13. To avoid fire, do not heat the hydraulic components (tanks, pipes, hoses, cylinders) before they have been drained and washed.
14. Use eye protection or a face mask to protect the eyes and respiratory system against dust and other foreign particles.

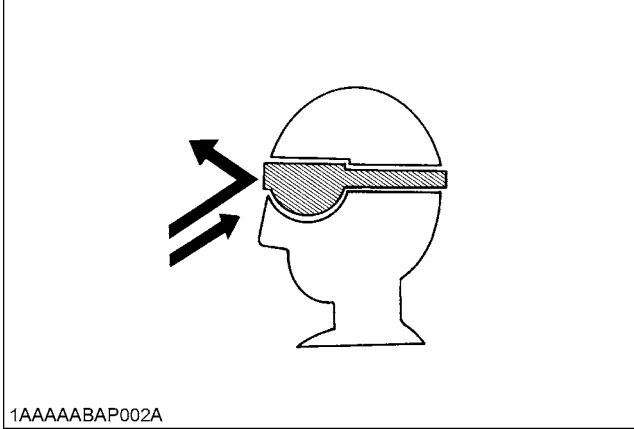

15. Securely support excavator with stands or suitable blocking before working underneath. For your safety, do not work under any hydraulically supported devices. They can settle, suddenly leak down, or be accidentally lowered.

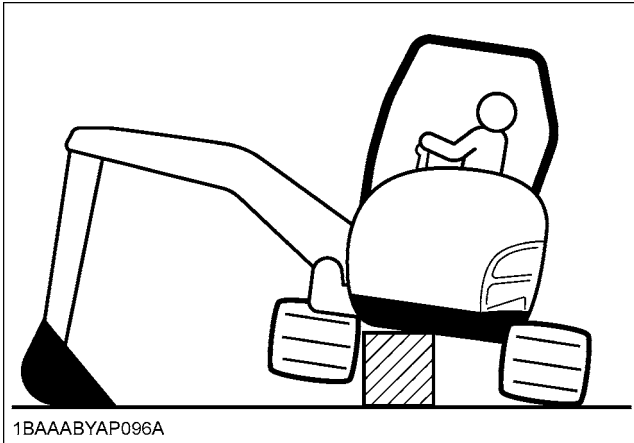

16. Do not dismantle the spring of the track tensioner. If dismantling is necessary, contact your KUBOTA dealer where the machine was purchased, or competent service shop. The assembly must be done according to the KUBOTA work shop manual (W.S.M.) for the product involved.
17. When lifting the machine itself with an attachment, place a safety block or safety post to prevent the machine from rolling over. Keep the lock lever for attachment control in the "LOCK" position.

18. Inspect ROPS / FOPS for damage and if damage is found contact your KUBOTA dealer for repair.

19. KUBOTA does not use asbestos containing components and recommends against the use of such components.

Components containing asbestos should be handled in accordance with applicable regulations and industry practice.

20. Fire prevention

Excavator and some attachments have components that are at high temperatures under normal operating conditions. The primary source of high temperatures is the engine and exhaust system. The electrical system, if damaged or incorrectly maintained, can be a source of arcing or sparks.

The following fire prevention guidelines will help to keep your equipment up and running efficiently and keep the risk of fire to a minimum.

- Blow off all accumulated debris near hot engine exhaust components such as turbocharger and exhaust manifold as well as exhaust pipes and muffler more frequently when working in severe conditions.
- Clean out all accumulated flammable debris such as leaves, straw, pine needles, branches, bark, small wood chips and any other combustible materials from inside the machine belly pans or lower unit structures as well as from area in proximity to the engine.
- Inspect all fuel lines and hydraulic hoses for wear or for deterioration. Replace them immediately if they begin to leak.
- Examine electrical wiring and connectors frequently for damage. Repair any wires that are loose or frayed before operating the machine. Clean all electrical connections and tighten all electrical connections as necessary.
- Inspect the exhaust system daily for any signs of leakage. Check for broken pipes and muffler and also for loose or missing bolts, nuts and clamps. If any exhaust leaks or fractured parts are found, repairs must be completed prior to operation.
- Always keep a multipurpose fire extinguisher on or near the machine. Be familiar with the operation of the fire extinguisher.

6. DANGER, WARNING AND CAUTION LABELS

(1) Part No. RD809-5736-1

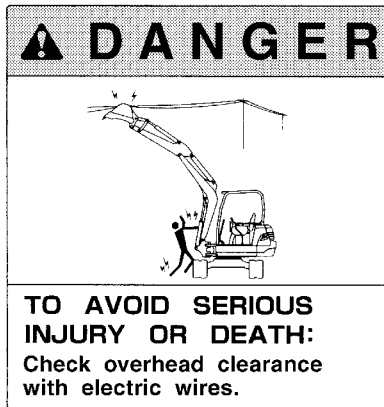

1BAAAQAP0800

(2) Part No. RD809-5738-2

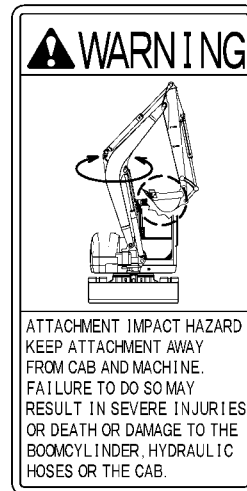

1BAAAARAP1000

(3) Part No. RB419-5793-1 [CAB]

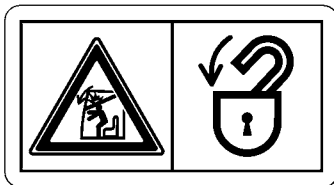

1BAAABYAP158E

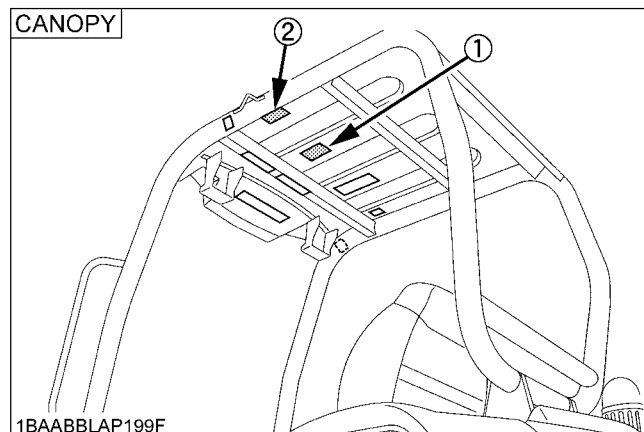
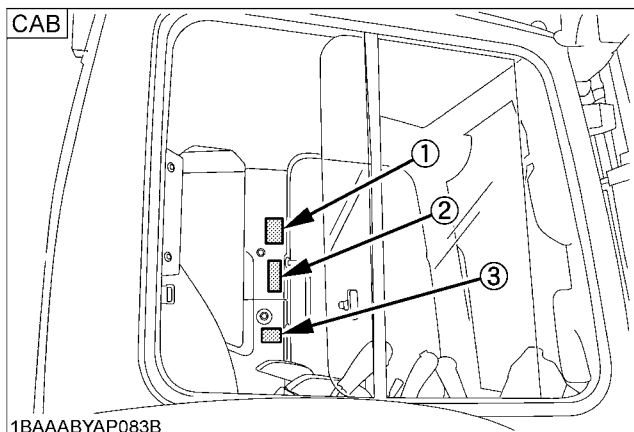

(1) Part No. RD809-5728-2

<p>CAUTION</p>	<p>TO AVOID PERSONAL INJURY :</p>
	<ol style="list-style-type: none"> 1. Read and understand operator's manual before attempting to start or operate the excavator. Read the manual of the attachment to do a correct operation safely when other attachments are installed instead of Kubota specified bucket. 2. Before starting engine, make sure all control levers are in neutral and the operating area is clear of all bystanders. 3. Never allow passengers on any part of the excavator while operating. 4. Know your work area before starting operation. 5. Check underground lines and cables. ● Stay off slopes too steep for safe operation. 6. Make sure all shields are in place and securely fastened. 7. Before dismounting from the machine, lower all attachment to the ground. Stop the engine and remove the key. <p>● Damaged ROPS must be replaced, not repaired or revised.</p> <p>Never use boom, dipper, or bucket to hammer or beat sideways. Excavator is not intended for these usages.</p>
<p>IMPORTANT</p>	



1BAAABBAP120E

(2) Part No. RD458-5737-1

<p>CAUTION</p>	<p>TO AVOID PERSONAL INJURY :</p>
	<p>Do not open engine hood before stopping engine. Only when engine does not stop with the key. Pull back this stop button and hold it until the engine stops.</p>

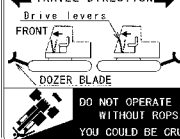

1BAAABYAP116E

(3) Part No. RD809-5727-1 [CAB]

<p>WARNING</p>	
<p>← TRAVEL DIRECTION →</p> 	<p>TO AVOID PERSONAL INJURY OR DEATH: Before moving the excavator, KNOW THE LOCATION OF THE DOZER BLADE. The excavator will travel in the direction of the dozer blade when drive levers are moved away from the operator.</p>
<p>DO NOT OPERATE WITHOUT ROPS. YOU COULD BE CRUSHED.</p> 	<p>USE SEAT BELT</p> 

1BAAABBAP119E

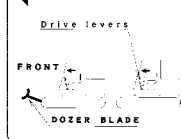
(3) Part No. RC418-5727-4 [CANOPY]

<p>WARNING</p>	
<p>← TRAVEL DIRECTION →</p> 	<p>TO AVOID PERSONAL INJURY OR DEATH: Before moving the excavator, KNOW THE LOCATION OF THE DOZER BLADE. The excavator will travel in the direction of the dozer blade when drive levers are moved away from the operator.</p>
<p>DO NOT OPERATE WITHOUT ROPS. YOU COULD BE CRUSHED.</p> 	<p>USE SEAT BELT</p> 

1BAAAAQAP0790

(4) Part No. RD358-5745-1

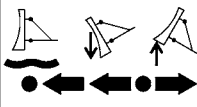
<p>WARNING</p>	
<p>TO AVOID PERSONAL INJURY OR DEATH Do not push the dozer control lever into the float position while the machine is supported by the dozer blade.</p>	

1BAAABYAP120E

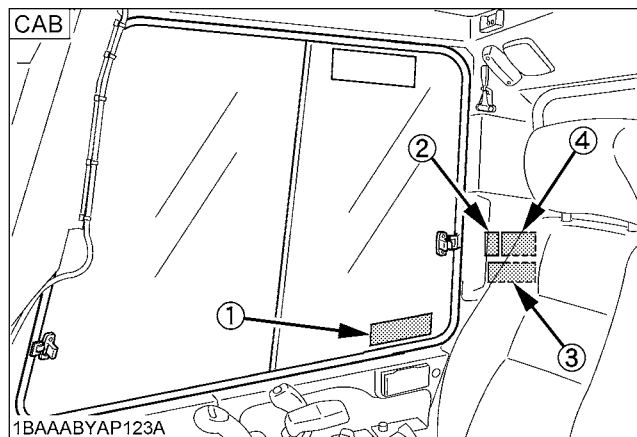

1BAAABYAP123A

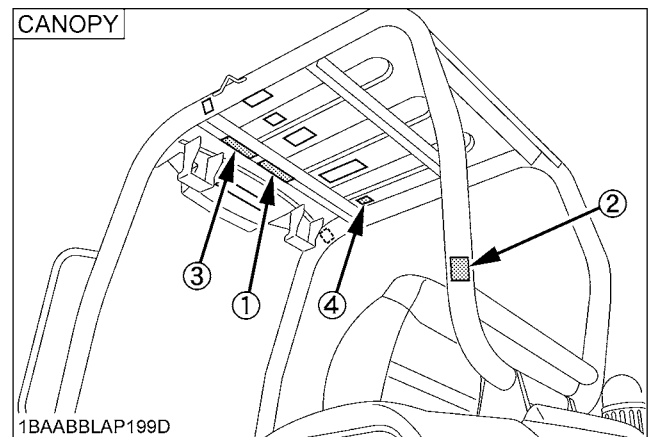

1BAABBLAP199D

(1) Part No. RC108-5765-2 [CAB]

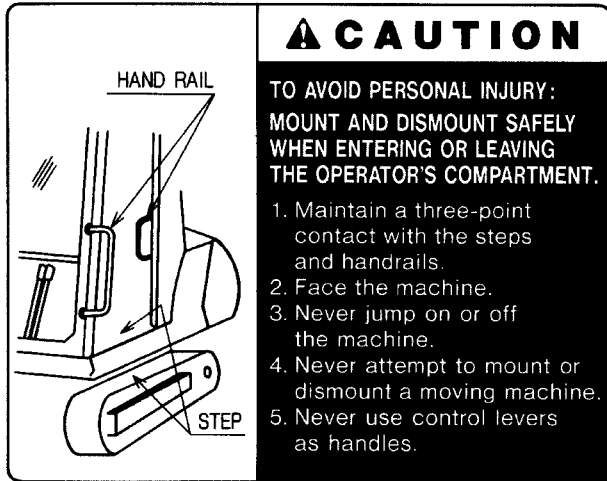

1BAAGAAP0140

(1) Part No. RD118-5763-1 [Canopy]

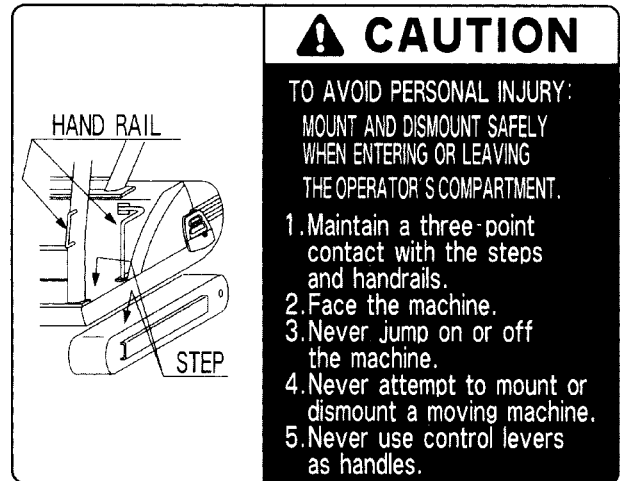

1BAAGAAP0160

(2) Part No. RC418-5753-2

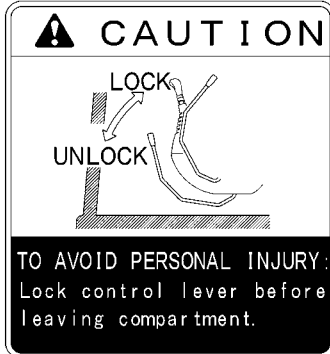

1BAAABYAP138E

(3) Part No. RC418-5732-3

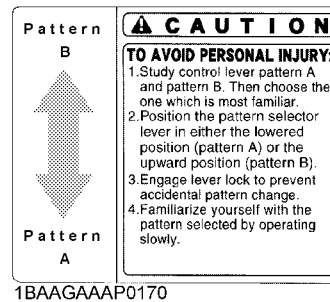

1BAAGAAP0170

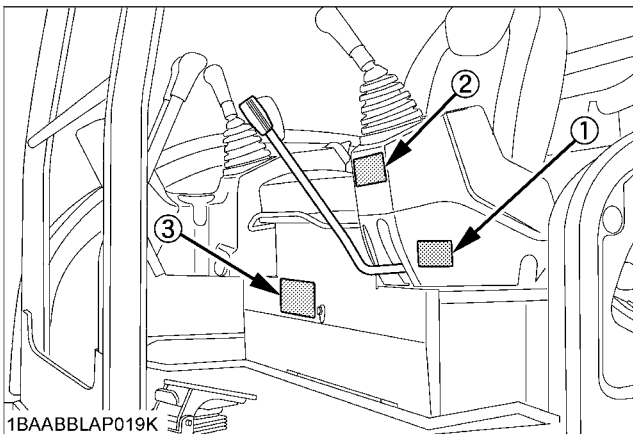

(1) Part No. RD148-5736-1
 Diesel fuel only No fire

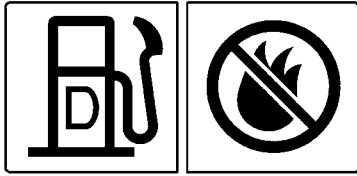

LOW SULFUR FUEL OR
 ULTRA LOW SULFUR
 FUEL ONLY

1BAAGAAP1000

(2) Part No. RC418-5725-1
 Do not allow any persons within the working range.

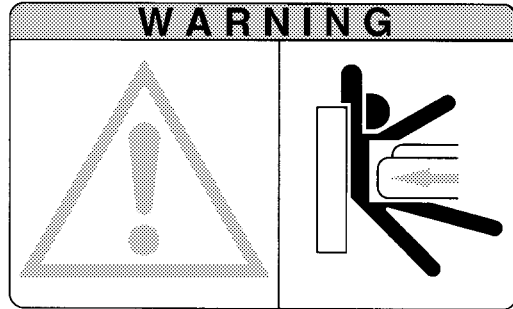

1BAAGAAP0240

(3) Part No. RC108-5718-1

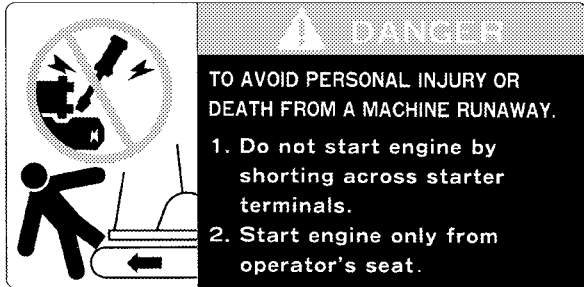

1BAAGAAP0250

(4) Part No. RC108-5714-1



1BAAGAAP0260

(5) Part No. RD118-5765-2



1BAAGAAP0310

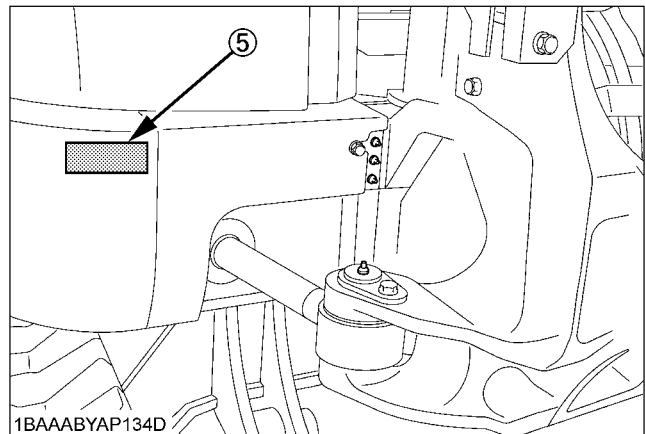

1BAAABYAP134D

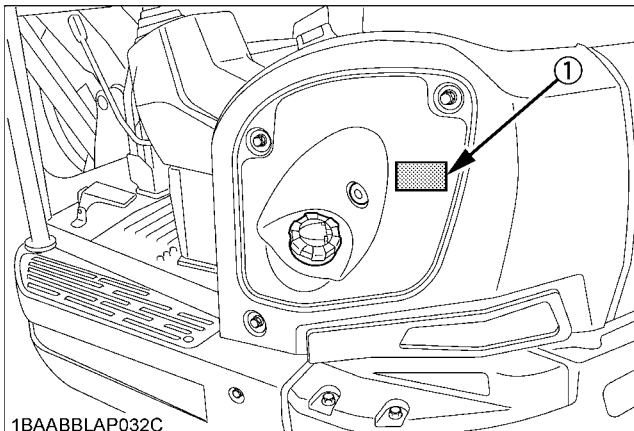

1BAABBLAP032C

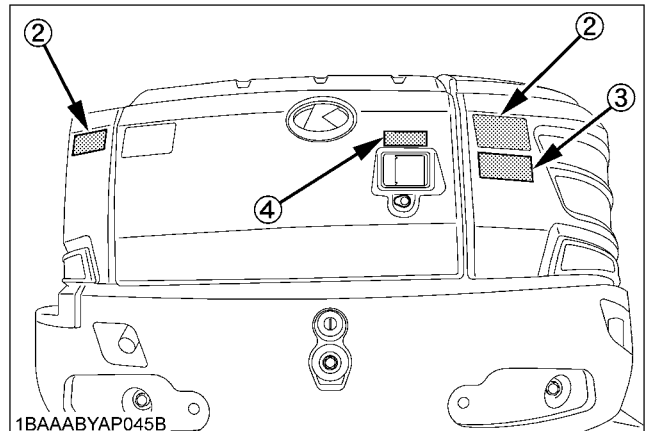

1BAAABYAP045B

- (1) Part No. TA040-4958-1
Do not touch hot parts such as exhaust etc.

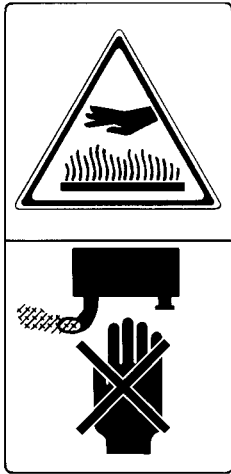

1BAAGACAP0280

- (2) Part No. RC418-5737-2
Keep away from fan and fan belt.



1BAAAAQAP0880

- (3) Part No. 6C040-5559-1

DANGER EXPLOSIVE GASES
Cigarettes, flames or sparks could cause battery to explode. Always shield eyes and face from battery. Do not charge or use booster cables or adjust post connections without proper instruction and training.
KEEP VENT CAPS TIGHT AND LEVEL
POISON CAUSES SEVERE BURNS
Contains sulfuric acid. Avoid contact with skin, eyes or clothing. In event of accident flush with water and call a physician immediately.
KEEP OUT OF REACH OF CHILDREN

1BAAGAAP0360

- (4) Part No. RC108-5754-1

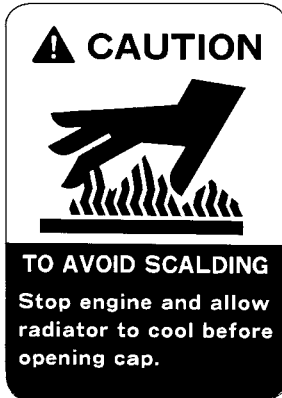

1BAAAAQAP0890

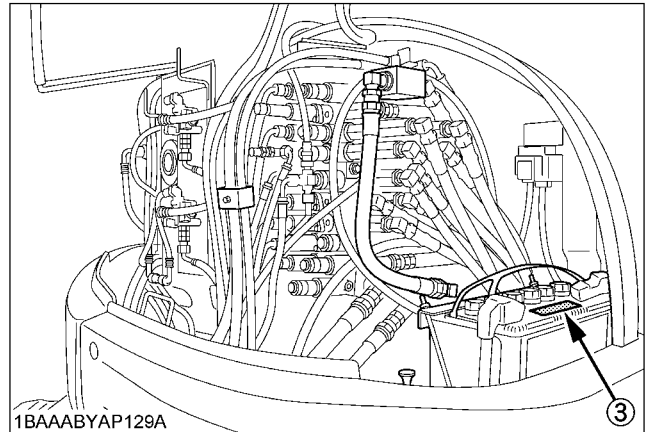

1BAAABYAP129A

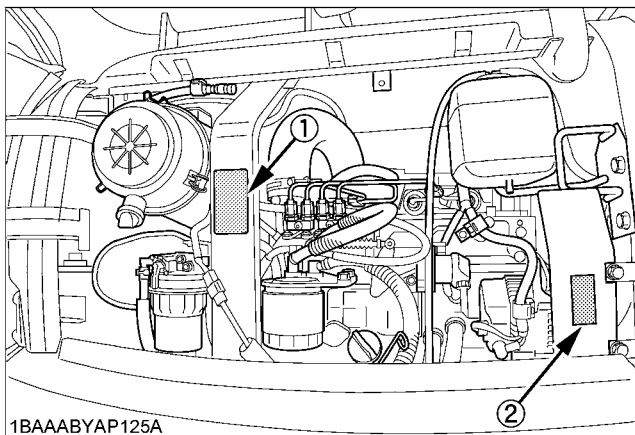

1BAAABYAP125A

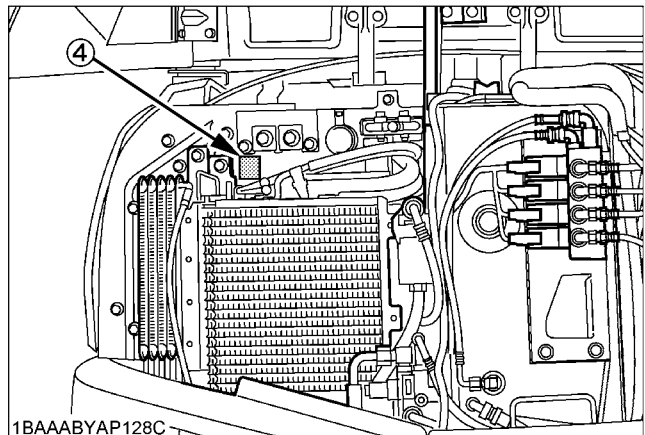

1BAAABYAP128C

- (1) Part No. RD809-5795-1
Do not loosen the grease nipple completely or too quickly.

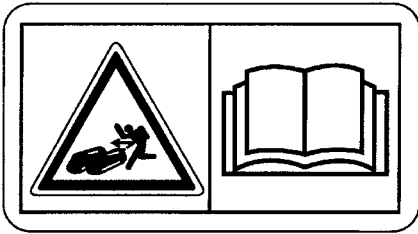

1BAABAMAP0010

- (2) Part No. RC108-5796-1 [Both sides]

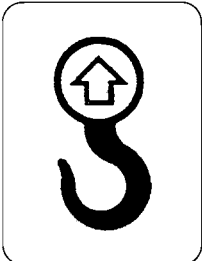

1BAAAQAP0940

- (3) Part No. 68328-5735-1 [Both sides]

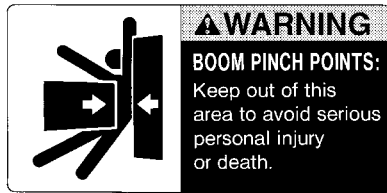

1BAAGAAP0270

- (4) Part No. RB419-5796-1 [Both sides]

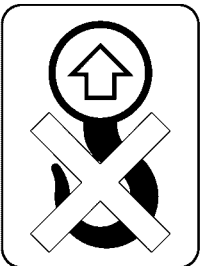

1BAABAUAP2720

- (5) Part No. RD358-5785-1 [CAB]



1BAAABYAP137E

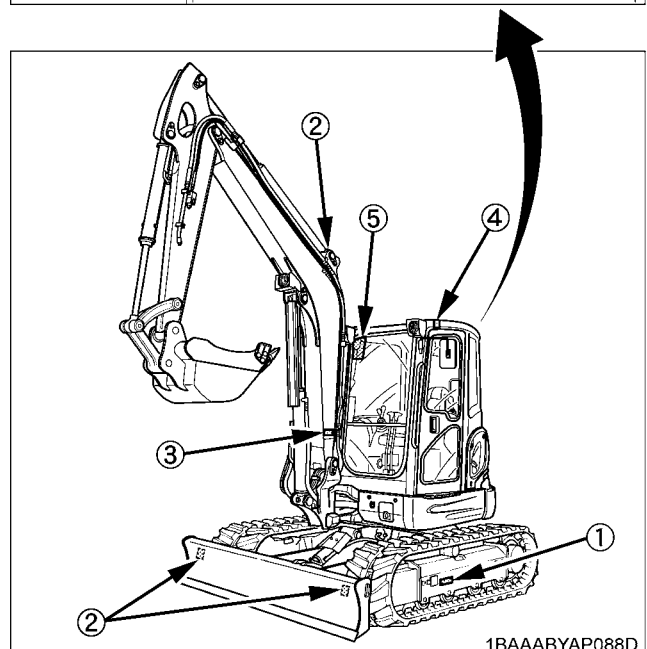
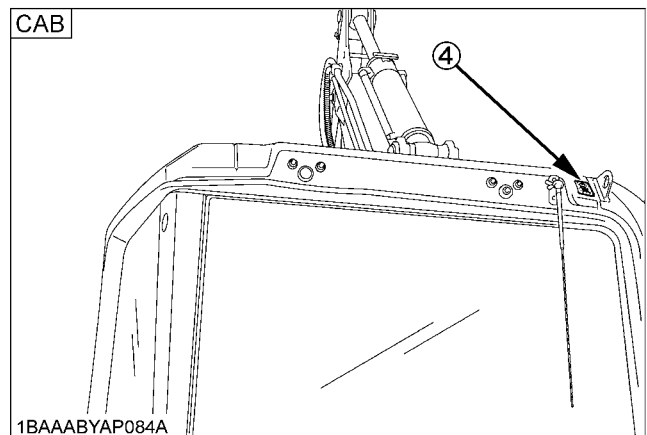
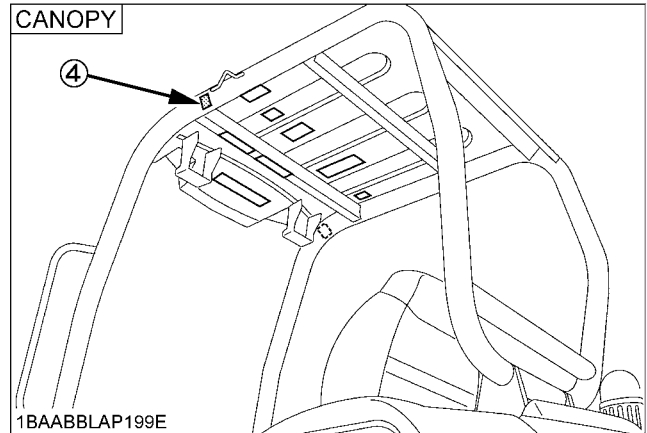

(1) Part No. RD358-5748-2 [KX057-4]

▲WARNING

TO AVOID PERSONAL INJURY OR DEATH:

- Do not move raised load over people.
- It is forbidden to lift loads greater than those values mentioned in the lifting capacity table.
- The values mentioned in the table are valid only on even, hard grounds. When lifting on soft ground, the machine can tilt over due to the fact that the load is concentrated only on one side of the machine.
- The table values are calculated at the end of the arm with out the bucket. In order to find the allowable loads for machines with bucket, the bucket weight must be subtracted from the values in the table.

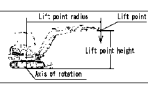

1. The lifting capacities are based on ISO 10567 and do not exceed 75% of the static tilt load of the machine or 87% of the hydraulic lifting capacity of the machine.

2. The strokes are as follow:

- The load point corresponds to the front bolt part of the arm.
- The machine positions are (i) over-front (blade down), (ii) over-front (blade up), and (iii) over-side.
- The operating cylinder is the boom cylinder.

3. The bucket of the excavator, the hook, the sling and other lifting accessories are taken into consideration for the loads.

LIFT POINT HEIGHT (m)	LIFTING CAPACITY OVER-FRONT BLADE DOWN Unit=t=kl (kg)					LIFTING CAPACITY OVER-FRONT BLADE UP Unit=t=kl (kg)					LIFTING CAPACITY OVER-SIDE Unit=t=kl (kg)					
	LIFT POINT RADIUS (m)					LIFT POINT RADIUS (m)					LIFT POINT RADIUS (m)					
	MIN	1.5	3	4.5	MAX	MIN	1.5	3	4.5	MAX	MIN	1.5	3	4.5	MAX	
4																
3				10.2 (1040)	8.7 (890)				8.6 (880)	7.1 (730)				7.3 (740)	6.0 (610)	
2			15.4 (1570)	11.2 (1140)	8.7 (890)				15.4 (1570)	8.4 (860)	6.4 (660)				18.2 (1840)	5.4 (560)
GL 1			20.7 (2120)	12.4 (1270)	9.3 (950)				15.0 (1530)	8.1 (830)	6.1 (630)				12.2 (1240)	8.8 (900)
0			23.0 (2350)	13.2 (1340)	10.5 (1070)				14.3 (1450)	7.8 (800)	6.3 (640)				11.6 (1180)	8.5 (870)
-1	16.9 (1720)	22.3 (2270)	21.9 (2240)	16.5 (1670)	16.9 (1720)	22.3 (2270)	14.1 (1440)	14.1 (1440)	7.7 (790)	7.7 (790)	16.9 (1720)	22.3 (2270)	11.4 (1160)	11.4 (1160)	5.4 (560)	
-2	20.4 (2080)	26.8 (2730)	17.5 (1790)		23.8 (2430)	26.8 (2730)	14.3 (1480)	14.3 (1480)			20.4 (2080)	26.8 (2730)	11.5 (1180)	11.5 (1180)		

Machine with ROPS canopy and rubber crawler, without bucket.

1BAAABYAP160E

(1) Part No. RD558-5748-2 [U55-4]

▲WARNING

TO AVOID PERSONAL INJURY OR DEATH:

- Do not move raised load over people.
- It is forbidden to lift loads greater than those values mentioned in the lifting capacity table.
- The values mentioned in the table are valid only on even, hard grounds. When lifting on soft ground, the machine can tilt over due to the fact that the load is concentrated only on one side of the machine.
- The table values are calculated at the end of the arm with out the bucket. In order to find the allowable loads for machines with bucket, the bucket weight must be subtracted from the values in the table.

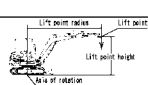

1. The lifting capacities are based on ISO 10567 and do not exceed 75% of the static tilt load of the machine or 87% of the hydraulic lifting capacity of the machine.

2. The strokes are as follow:

- The load point corresponds to the front bolt part of the arm.
- The machine positions are (i) over-front (blade down), (ii) over-front (blade up), and (iii) over-side.
- The operating cylinder is the boom cylinder.

3. The bucket of the excavator, the hook, the sling and other lifting accessories are taken into consideration for the loads.

LIFT POINT HEIGHT (m)	LIFTING CAPACITY OVER-FRONT BLADE DOWN Unit=t=kl (kg)					LIFTING CAPACITY OVER-FRONT BLADE UP Unit=t=kl (kg)					LIFTING CAPACITY OVER-SIDE Unit=t=kl (kg)					
	LIFT POINT RADIUS (m)					LIFT POINT RADIUS (m)					LIFT POINT RADIUS (m)					
	MIN	1.5	3	4.5	MAX	MIN	1.5	3	4.5	MAX	MIN	1.5	3	4.5	MAX	
4																
3				11.5 (1180)					7.6 (780)					6.4 (660)		
2			17.8 (1820)	12.2 (1240)	10.8 (1090)				14.1 (1440)	7.4 (760)	5.9 (600)				11.4 (1170)	6.2 (630)
GL 1			23.1 (2360)	13.4 (1360)	11.3 (1160)				12.9 (1320)	7.1 (730)	6.7 (690)				10.5 (1080)	6.9 (710)
0			24.4 (2490)	13.9 (1410)	10.8 (1110)				12.4 (1260)	6.9 (710)	6.8 (700)				9.9 (1010)	6.7 (690)
-1	14.4 (1470)	25.1 (2570)	22.2 (2270)	12.8 (1270)	14.4 (1470)	25.1 (2570)	12.3 (1250)	12.3 (1250)	6.9 (700)	6.9 (700)	14.4 (1470)	25.1 (2570)	10.1 (1030)	10.1 (1030)	5.7 (590)	
-2	18.6 (1890)	26.5 (2700)	16.5 (1680)		20.4 (2070)	26.5 (2700)	12.6 (1290)	12.6 (1290)			18.6 (1890)	26.5 (2700)	10.1 (1030)	10.1 (1030)		

Machine with ROPS canopy and rubber crawler, without bucket.

1BAAABYAP121E

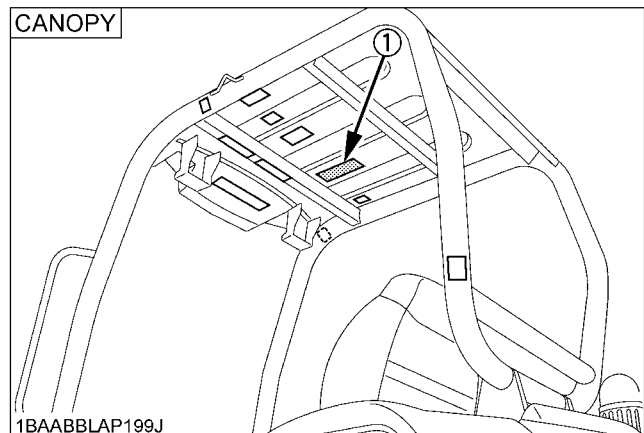
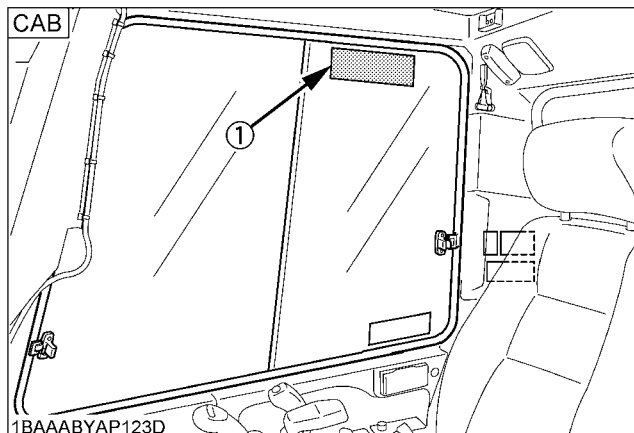

7. CARE OF DANGER, WARNING AND CAUTION LABELS

1. Keep danger, warning and caution labels, clean and free from obstructing material.
2. Clean danger, warning and caution labels with soap and water, dry with a soft cloth.
3. Replace damaged or missing danger, warning and caution labels with new labels from your KUBOTA dealer.
4. If a component with danger, warning and caution label(s) affixed is replaced with new part, make sure new label(s) is (are) attached in the same location(s) as the replaced component.
5. Mount new danger, warning and caution labels by applying on a clean dry surface and pressing any bubbles to outside edge.

DEALER SERVICE

Your KUBOTA dealer is always ready to help so that your excavator offers the best performance. After having carefully read these instructions, you will realize that much of the routine maintenance can be done by yourself. Your KUBOTA dealer is responsible for servicing and the delivery of spare parts. When ordering spare parts from your KUBOTA dealer, always mention the serial number of the excavator and the engine.

Note these numbers right away in the supplied lines.

	Model	Serial No.
Excavator		
Engine		
Dealer's name (To be filled in through the owner)		

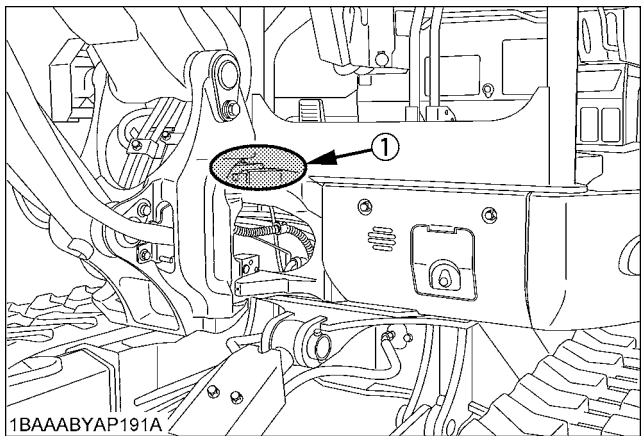
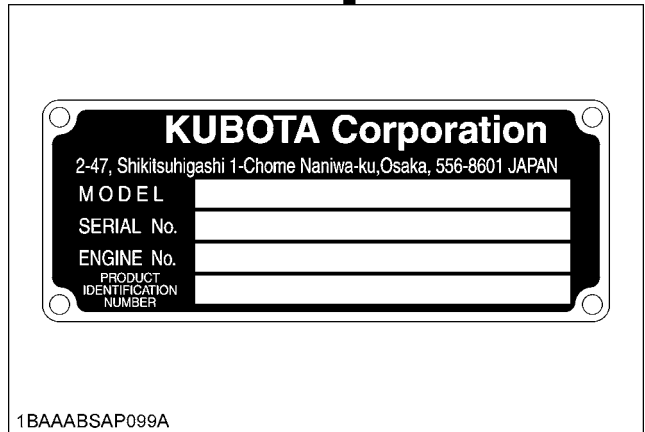
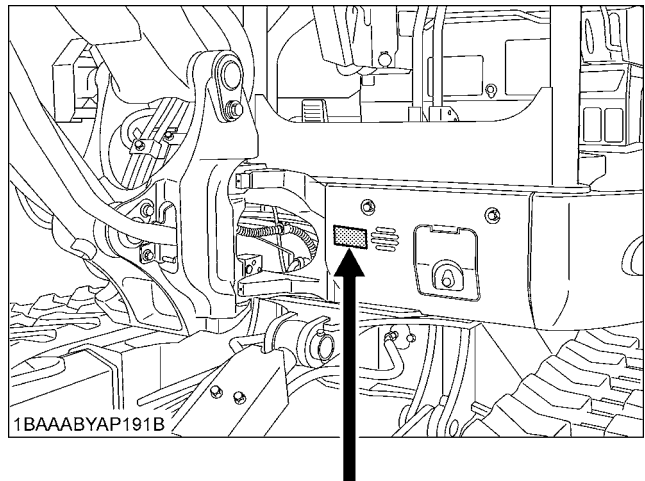

(1) Serial No.

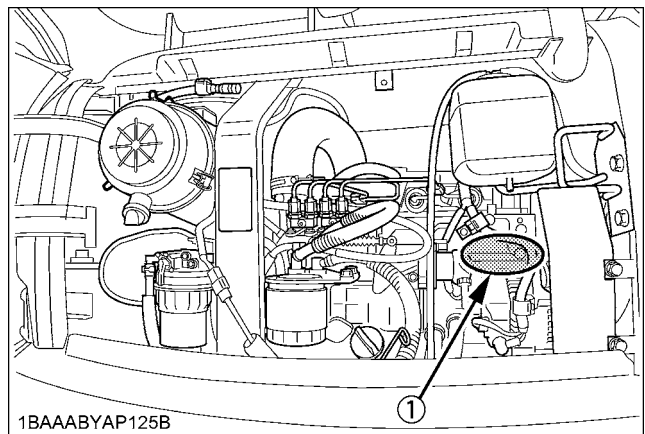

(1) Engine serial No.

TECHNICAL DATA

				KUBOTA EXCAVATOR	
Model name		KX057-4			
Type		Canopy		CAB	
Operating weight (including operator's)		kg	5510	5600	
Engine	Type		Water cooled 4 cycle diesel engine with 4 cylinder		
	Model name		(No air conditioner type) V2607-DI-E3-BH-5 (Air conditioner type) V2607-DI-E3-BH-3		
	Total displacement	cc	2615		
	Engine power SAE J1955 gross	kW	35.5		
	Rated speed	rpm	2200		
	Low idling speed	rpm	1050 to 1200		
Performance	Unit swing speed		rpm		
	Travel speed	Fast	km/h	4.9	
		Slow	km/h	2.8	
	Ground pressure (With operator)	kPa (kgf/cm ²)	30.9 (0.315)	31.4 (0.320)	
	Max. climbing angle	% (deg)	*36 (20)		
Angle in case of crossing slope	% (deg)	*27 (15)			
Dozer	Width x Height		mm		
		1960 x 410 (77.16 x 16.2)			
Boom swing angle		Left	rad (deg)	1.20 (70)	
		Right	rad (deg)	0.96 (55)	
Pressure connection for attachments	Max. displacement	L / min	75 (AUX 1 port) 37 (AUX 2 port)		
	Max. pressure	MPa (kgf/cm ²)	[AUX 1 port] 17.2 (175)	[AUX 2] 17.2 (175)	
Fuel tank capacity		L	75		

NOTE :

- Above dimensions are based on the machine with rubber track.
- Specifications subject to change without notice.
- * With unloaded digging bucket. (JPN STD Bucket)
- * Firm compacted soil.
- * Operators must exercise extra caution and follow instructions in the operator's manual.
- * Worse condition or heavier attachment to the above will decrease climbing angle.
- ROPS/FORS structure complies with ISO 3471, ISO 3449 and OSHA regulations.

				KUBOTA EXCAVATOR			
Model name				U55-4			
Type				Canopy		CAB	
Operating weight (including operator's)		kg		5380		5470	
Engine	Type			Water cooled 4 cycle diesel engine with 4 cylinder			
	Model name			(No air conditioner type) V2607-DI-E3-BH-5 (Air conditioner type) V2607-DI-E3-BH-3			
	Total displacement		cc		2615		
	Engine power SAE J1955 gross		kW		35.5		
	Rated speed		rpm		2200		
	Low idling speed		rpm		1050 to 1200		
Performance	Unit swing speed		rpm		9.3		
	Travel speed	Fast		km/h		4.9	
		Slow		km/h		2.8	
	Ground pressure (With operator)		kPa (kgf/cm ²)		30.0 (0.306)		30.5 (0.311)
	Max. climbing angle		% (deg)		*36 (20)		
Angle in case of crossing slope		% (deg)		*27 (15)			
Dozer	Width x Height		mm		1960 x 410		
Boom swing angle		Left		rad (deg)		1.20 (70)	
		Right		rad (deg)		0.96 (55)	
Pressure connection for attachments	Max. displacement		L / min		75 (AUX 1 port) 37 (AUX 2 port)		
	Max. pressure		MPa (kgf/cm ²)		[AUX1 port] 17.2 (175)		[AUX 2] 17.2 (175)
Fuel tank capacity			L		68		

NOTE :

- Above dimensions are based on the machine with rubber track.
- Specifications subject to change without notice.
- * With unloaded digging bucket. (JPN STD Bucket)
- * Firm compacted soil.
- * Operators must exercise extra caution and follow instructions in the operator's manual.
- * Worse condition or heavier attachment to the above will decrease climbing angle.
- ROPS/FORS structure complies with standards ISO 3471, ISO 3449 and OSHA regulations

DESCRIPTION OF MACHINE PARTS

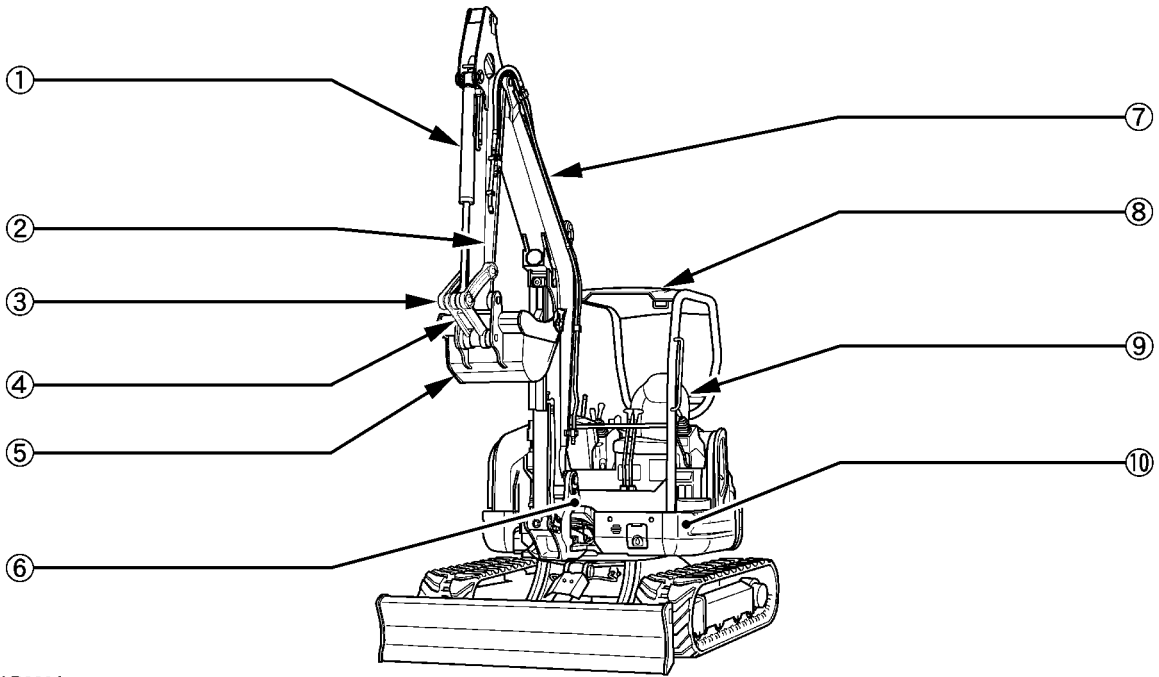

1BAAABYAP089A

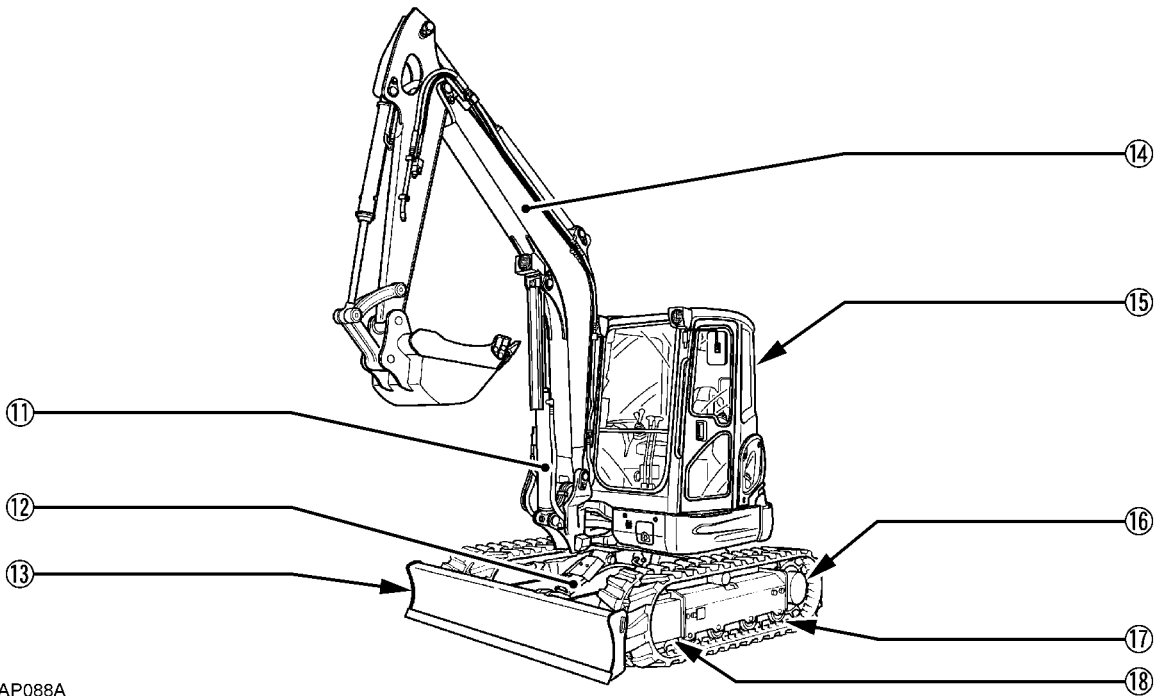

1BAAABYAP088A

DEPICTED CONTENTS

- | | | | |
|-------------------------|-------------------|---------------------|---------------------|
| (1) Bucket cylinder | (6) Swing bracket | (11) Boom cylinder | (16) Drive sprocket |
| (2) Arm | (7) Arm cylinder | (12) Dozer cylinder | (17) Track roller |
| (3) Bucket link 2 and 3 | (8) Canopy | (13) Dozer blade | (18) Front idler |
| (4) Bucket link 1 | (9) Seat | (14) Boom | |
| (5) Bucket | (10) Swing frame | (15) Cab | |

INSTRUMENT PANEL AND CONTROL ELEMENTS

■ Instrument Panel, Switch

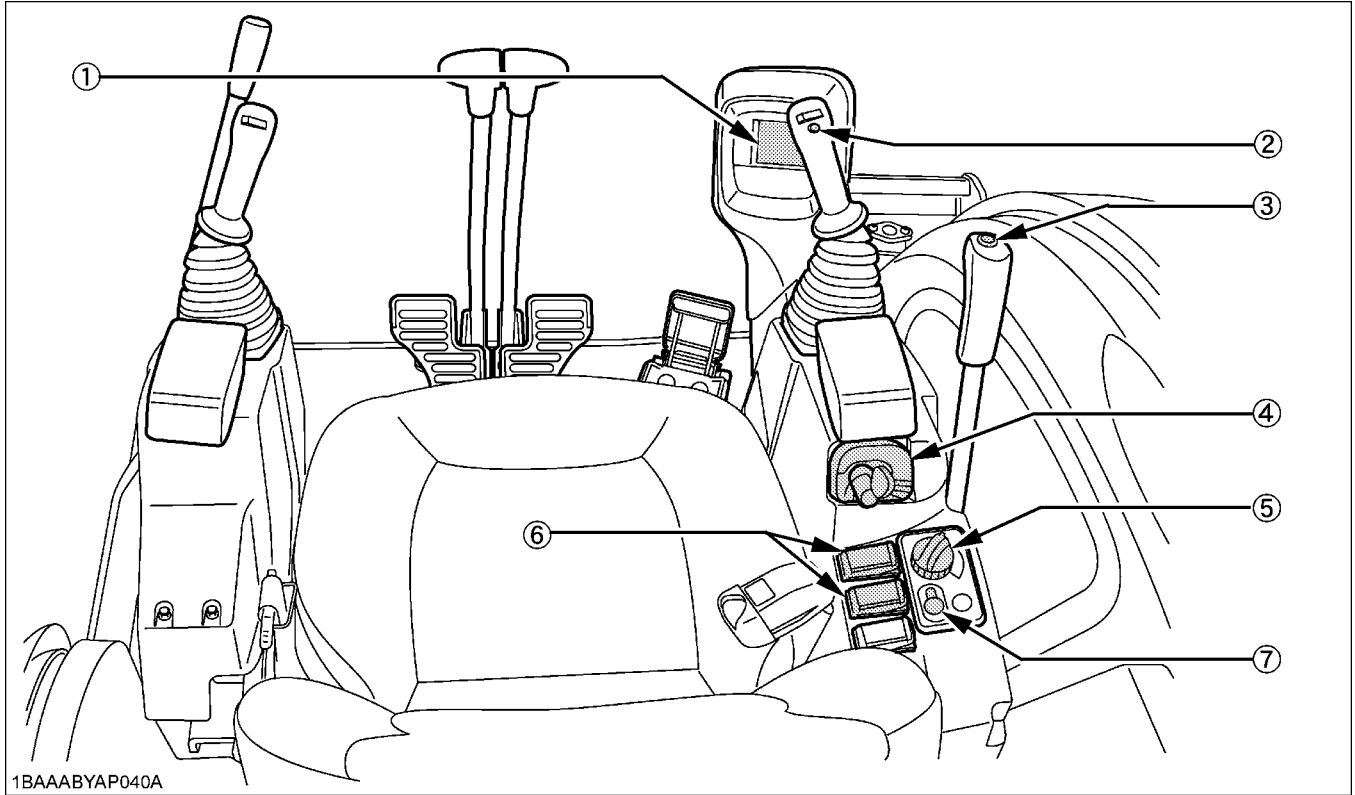

- (1) LCD display
- (2) Horn switch
- (3) Travel speed switch
- (4) Starter switch
- (5) Throttle potentiometer
- (6) Working light switch
- (7) Auto idle control switch

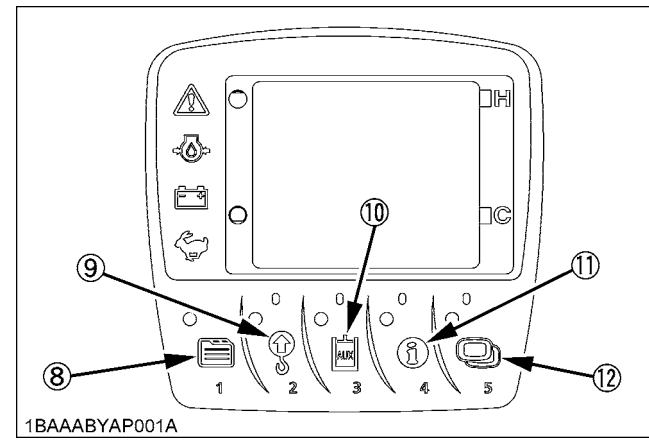

- (8) User setting switch (Switch 1)
- (9) - (Switch 2)
- (10) AUX port enable switch (Switch 3)
- (11) Information switch (Switch 4)
- (12) Display selector switch (Switch 5)

	Ref. page
Starter switch.....	7
LCD display.....	8
Fuel gauge	
Water temperature gauge	
Hour meter	
Engine tachometer	
Glow lamp	
User setting switch	
Overload warning switch	
AUX port enable switch	
Information switch	
Display selector switch.....	8
Warning lamp.....	11
Horn switch.....	18
Working light switch.....	18
Auto idle control switch.....	19
Throttle potentiometer.....	19
Travel speed switch.....	19

■ Control Pedals and Levers

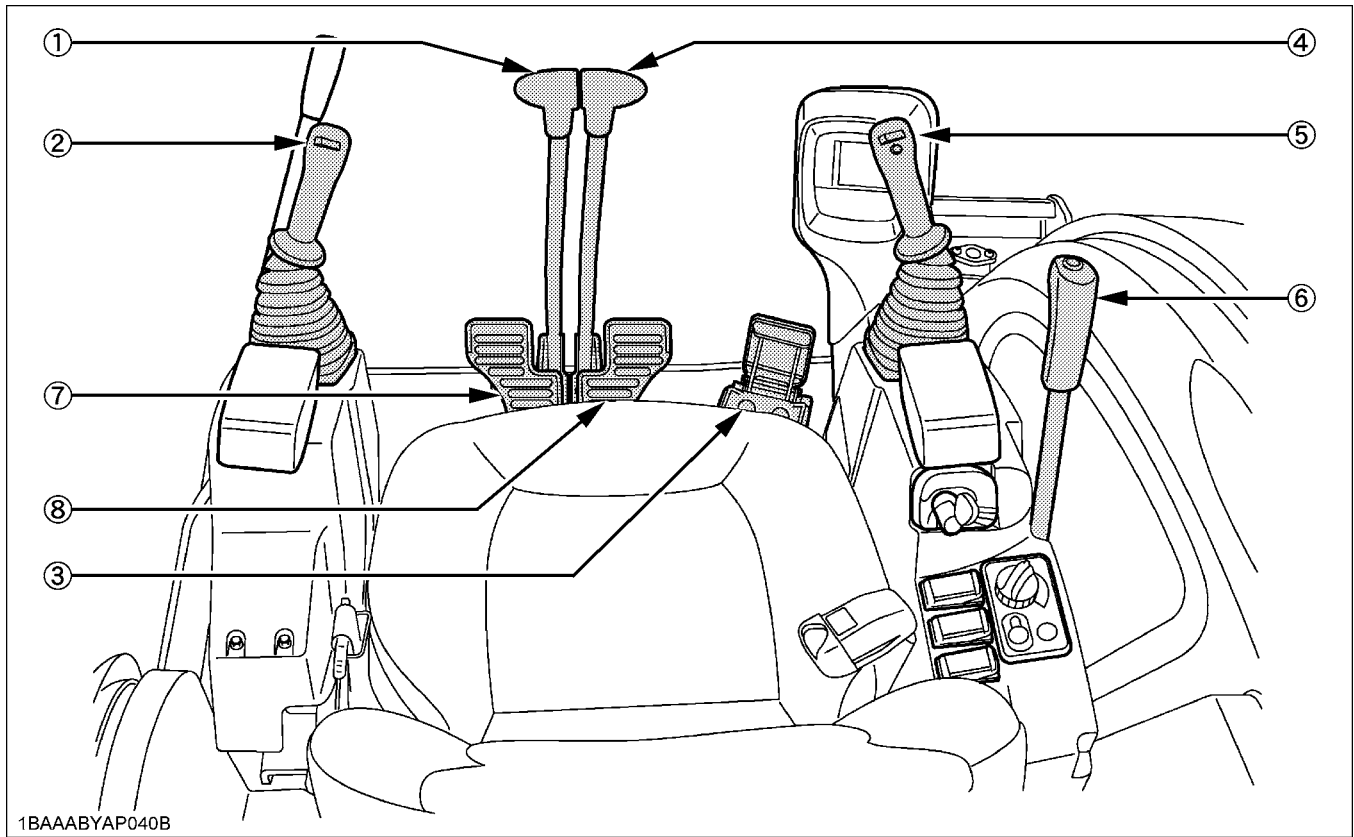

1BAAABYAP040B

- | | | | |
|-------------------------------------|-------------------------|--------------------------------------|-------------------------|
| (1) Drive lever (left) | (3) Boom swing pedal | (5) Attachment control lever (right) | (7) Drive pedal (left) |
| (2) Attachment control lever (left) | (4) Drive lever (right) | (6) Dozer control lever | (8) Drive pedal (right) |
- *Angle blade type

Ref. page

Drive lever (left)	32
Attachment control lever (left)	36, 37
Boom swing pedal	37
Drive lever (right)	32
Attachment control lever (right)	36, 37
Dozer control lever	34

CHECKS BEFORE START

DAILY CHECKS

In order to avoid damage, it is important to check the condition of the excavator before starting.



CAUTION

To avoid personal injury:

- Do maintenance work on the excavator only on level ground with the engine off and the lock lever in the "Lock" position.

Checks

Go around the excavator and check for visual damage and wear.

Check coolant level. (See "DAILY CHECKS" in "MAINTENANCE" section.)

Check fuel level.

Check engine oil level.

Check hydraulic fluid level.

Check air filter for clogging.

Check all grease points.

Check all control lamps, indicators, tachometer and hour meter.

Check the light system.

Check the seat belt and the ROPS/FOPS safety device.

Check the condition of the safety and warning labels.

(See "DANGER, WARNING AND CAUTION LABELS" in "SAFE OPERATION" section.)

Inspect ROPS / FOPS for damage and if damage is found contact your KUBOTA dealer for repair.

CHECKING THE DEVICES

■ Starter Switch

- [STOP]
The key can be inserted at the "STOP" position.
- [RUN]
Turn the key one click from the "STOP" position to the "RUN" position. All the circuitry gets energized to start preheating. The glow indicator is displayed. To check for any lamp breakage, however, the lamp lights up and stays on for about 1 second.
- [START]
Move the pilot control lock lever to the "LOCKED" position. Turn the key from the "RUN" position another click to the "START" position. The starter motor is then activated to get the engine started. Release your hand from the key, and the key returns itself to the "RUN" position. In other words, once the engine has started, be sure to free the key.

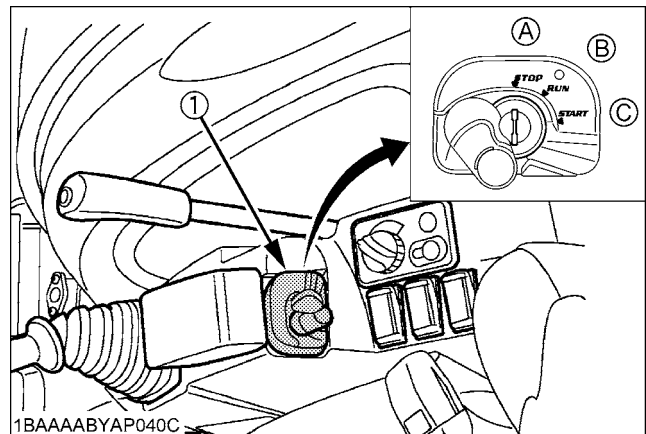

(1) Starter switch

(A) STOP
(B) RUN
(C) START

NOTE :

- If the key is repositioned from "RUN" to "STOP" but not pulled out, the message "**pull out key**" appears onscreen.
- With the key off and pulled out, nothing appears onscreen.

[Status with the key off but not pulled out]



1BAABBLAP259B

Display Selector Switch

Press the display selector switch while the engine is running. The LCD meter display will change from one indication mode to the other.

Change the two-mode display according to your jobs.

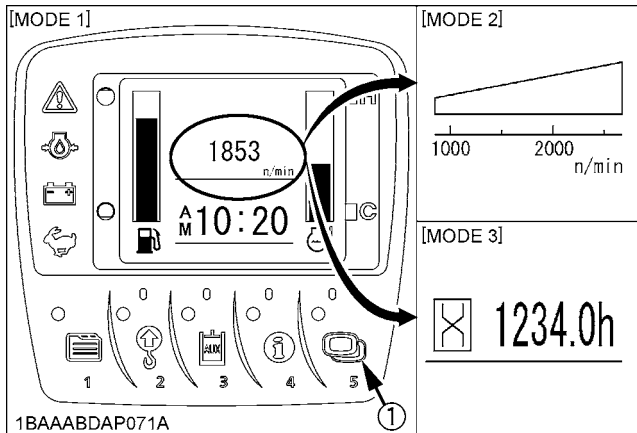

(1) Display selector switch

AUX port in use

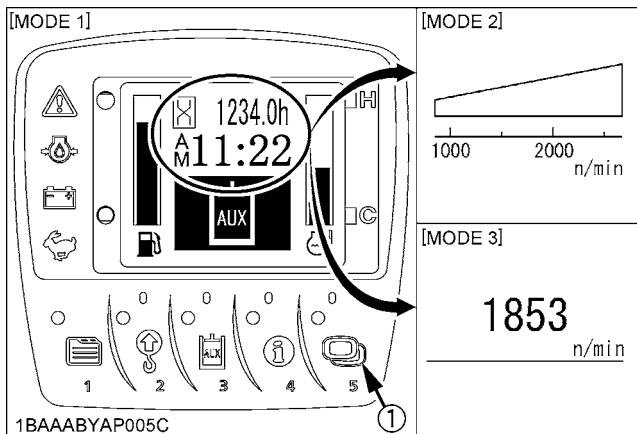

(1) Display selector switch

NOTE :

- Even with the starter key not yet inserted, press the electronic meter's user setting switch or the display selector switch, and the LCD display shows the hour meter, fuel gauge, water temperature gauge and clock for 10 seconds.

LCD Display for Normal Operation

Fuel gauge



CAUTION

To avoid personal injury:

- Before adding fuel, be sure to stop the engine.
- Be sure to keep open flame away from the machine. Otherwise a fire may result.

With the starter key at the "RUN" position, the fuel remaining in the fuel tank is indicated in the block.

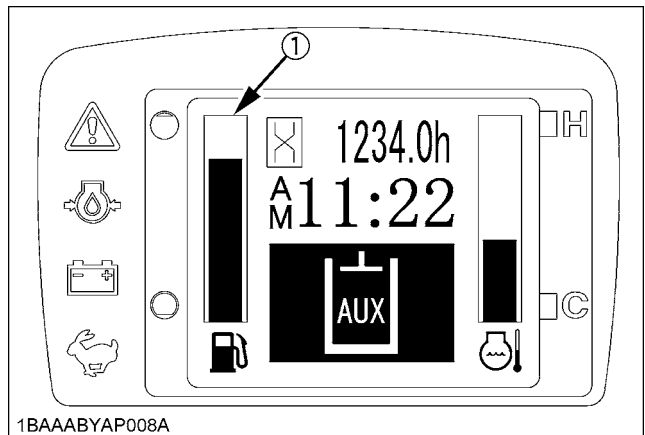

(1) Fuel gauge

If the fuel runs short, open the cap and refuel the tank.

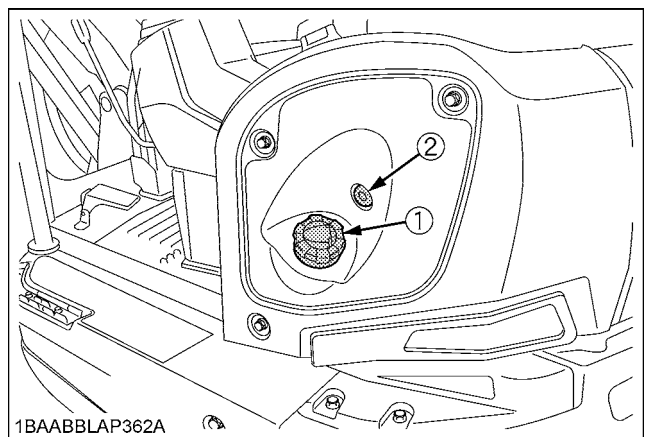

(1) Fuel cap
(2) Fuel level audible indication switch

IMPORTANT :

- If the fuel gauge indicator is near the "E" or the "FUEL" message appears, add fuel as soon as possible. If the indicator is near "E" and the machine is operated on a slope, the engine may run out of fuel.

NOTE :

- To open the fuel cap, keep the key inserted.

◆ Fuel level audible indication switch (when refueling)

1. With the starter key at the "OFF" position, press the fuel level audible indication switch, and the fuel level can be checked by the buzzer.
2. Start refueling the machine. The buzzer beeping intervals vary according to how much fuel is poured into the tank. As the fuel tank is filled up, the buzzer will sound almost continuously.
3. While refueling the machine, listen to the buzzer to know how much the fuel tank is filled.
4. If fuel is poured too slowly, the buzzer will stop beeping. When resumed normally, the buzzer will start beeping.
5. To stop refueling halfway (before filling up), press the fuel level audible indication switch or simply stop refueling for a while. The buzzer will stop sounding.

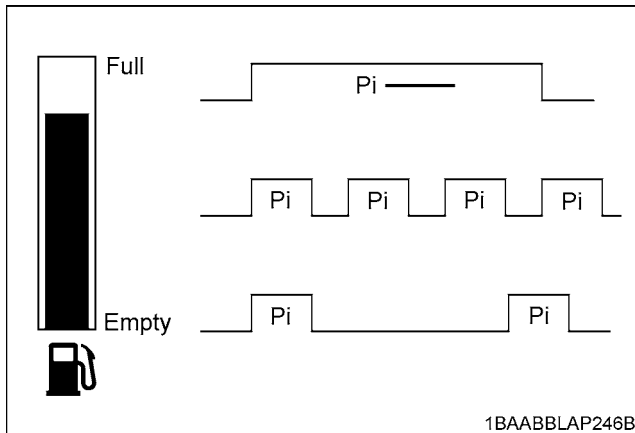

◆ Coolant Temperature Gauge



CAUTION

To avoid personal injury:

- Do not open the radiator cap during or just after operation. Hot coolant may gush out and scald you. Wait for the coolant to cool down before opening the cap.

With the starter key at the "RUN" position, the coolant temperature is indicated.

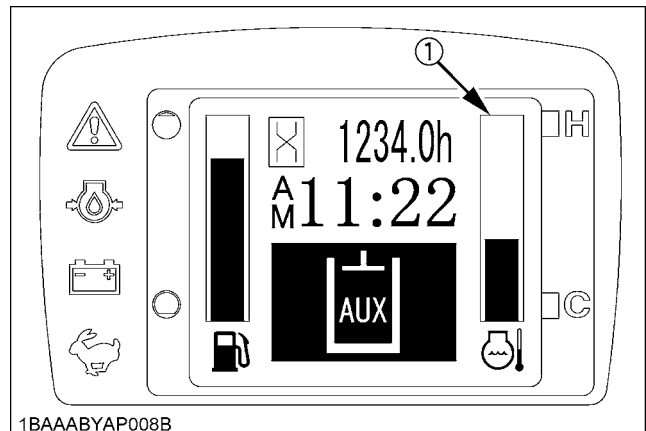

(1) Coolant temperature gauge

If the coolant temperature indicator is near "H", take the steps below.

Depending on the coolant temperature, the warning message "Water temp. is rising" or "Overheat Engine to idle for cooling" appears. In either case too, follow the same procedure below.

1. Discontinue the job.
2. Reduce engine rpm's to idle and keep it at idle for 5 minutes.
3. Stop the engine and check the following points (1)-(4).
 - (1) Low coolant level or leak
 - (2) Fan belt tension
 - (3) Mud or dust deposits on radiator
 - (4) Hydraulic oil leak

◆ **Overheat warning**

1. If the coolant temperature becomes too high, the message **"Water temp. is Rising"** appears onscreen for a certain period of time. The LCD display then gets back to normal, but the coolant temperature sensor marker "🌡️" starts blinking at 1-second intervals.

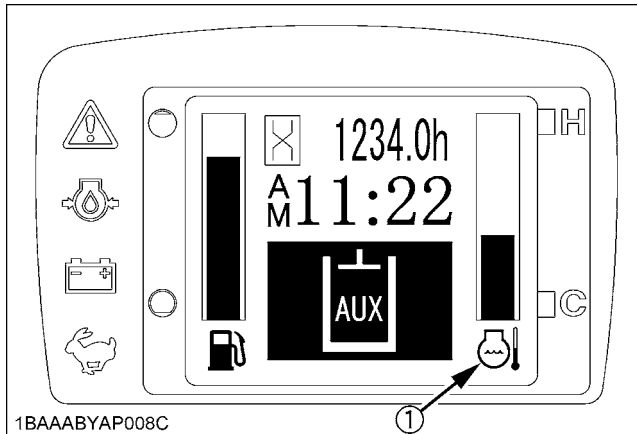

(1) Coolant temperature sensor marker

2. The overheat warning appears onscreen. Also the following message shows up on the LCD display, and the engine automatically starts idling. (Acceleration is not operative.)



If the above message appears, take corrective measures, referring to the **"Precautions in case of Overheat"** section.

NOTE :

- When the coolant temperature has dropped, acceleration can be automatically enabled.

◆ **Hour-meter**

Indicates the total operating hours of the machine.

How the indicator works

- The meter advances one hour after an hour of operation regardless of the engine rpm.

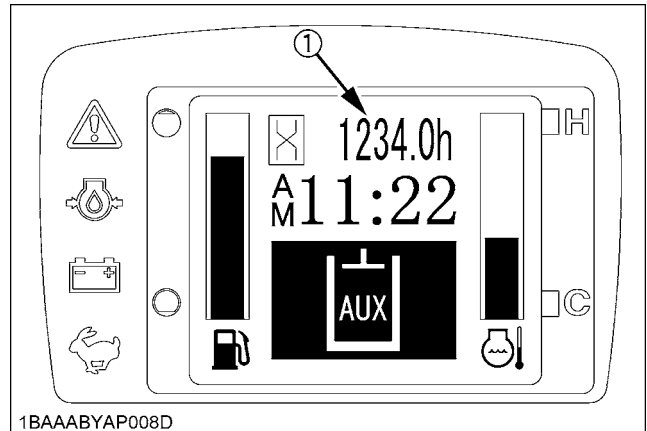

(1) Hour-meter

◆ **Engine tachometer**

Indicates the current rpm of the engine.

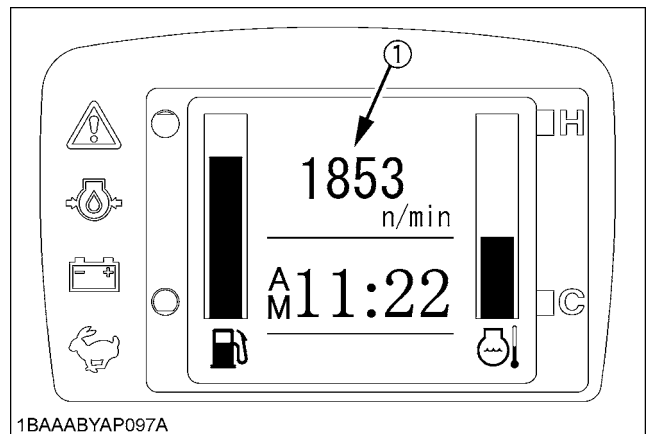

(1) Engine tachometer

◆ Glow indicator

The indicator is displayed when the starter key is turned to the "RUN" position but the engine requires preheating. Wait until the indicator goes out, and then start the engine.

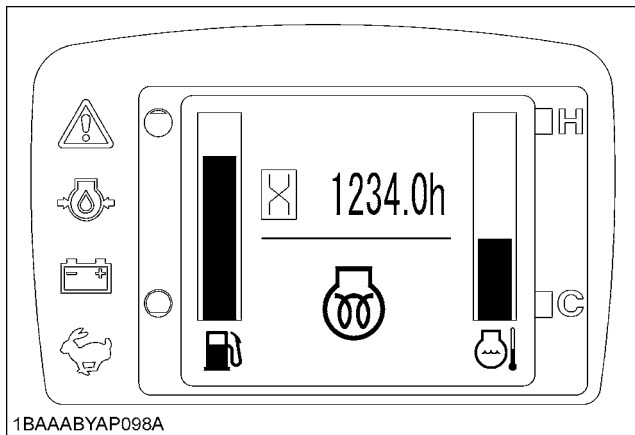

(1) Glow indicator

■ Warning Lamp

The warning lamp is used to indicate broken wire, short-circuit, fuel shortage and other problems.

The warning lamp starts flashing in red if any problem occurs. If the system senses a warning signal, the warning lamp starts flashing in yellow.

IMPORTANT :

- If the warning illuminates, do not just look at the meter; carry out the appropriate inspection and correction accordingly.
(See "**REGULAR CHECKS AND MAINTENANCE WORK**" section)

NOTE :

- If any warnings and problems are displayed, an alarm buzzer will beep. (See "**LIST OF SCREENS**" section for detail.)
- See your KUBOTA dealer from details concerning care and maintenance.

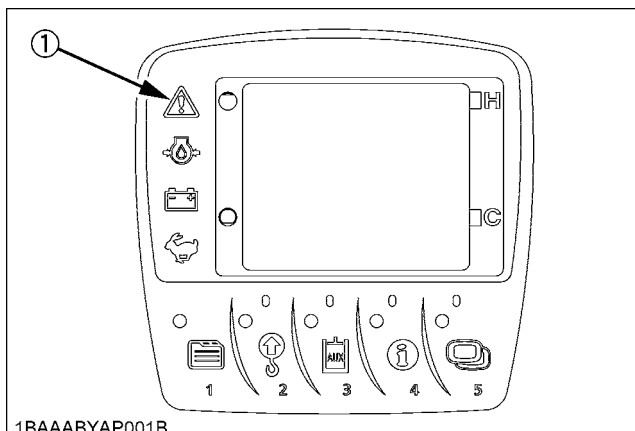

(1) Warning lamp (red, yellow)

■ LCD Display for Warning

◆ Remaining fuel warning

When the fuel level is very low, the  lamp (yellow) starts flashing and the following message appears in the display.



NOTE :

- After a short period of time, the display comes back to normal.
- After a short period of time, the message shows up again.
- Even while in the normal display mode, the warning lamp keeps on blinking.
- To see what warning is being given out, press the display selector switch. The current warning can then be identified.

◆ Battery charge warning

If the starter key is turned to the "RUN" position without starting the engine, and the charging lamp stays off, the charging system has failed. If such occurs, immediately contact your local dealer for repair.

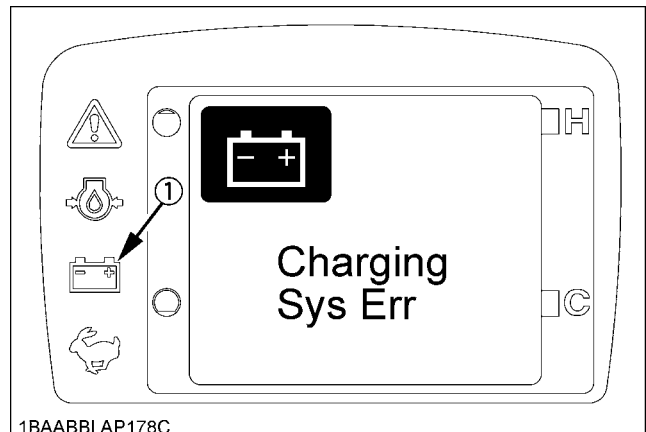

(1) Charging lamp

◆ Engine oil pressure low warning

When the engine oil pressure drops too low, the  lamp (red) starts flashing and the following message appears in the display.

Immediately stop the engine and check the engine oil level.

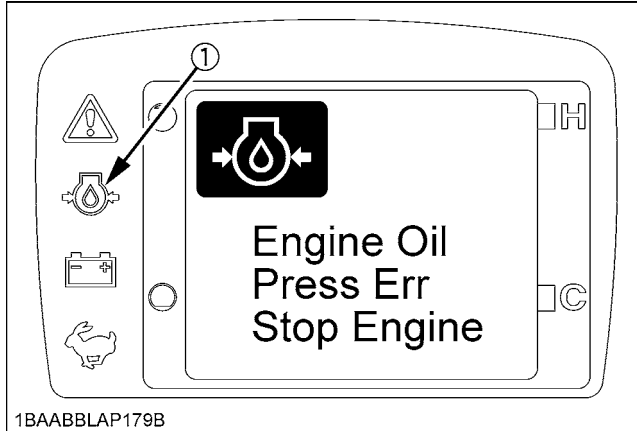

(1) Oil lamp

NOTE :

- If the starter key is turned to the "RUN" position without running the engine and the oil lamp stays off, then the hydraulic system may have failed. If such occurs, immediately contact your local dealer for repair.

◆ Various error warnings

If any components are detected to be in trouble, the following message appears onscreen. (See "LIST OF SCREENS" section)



Information

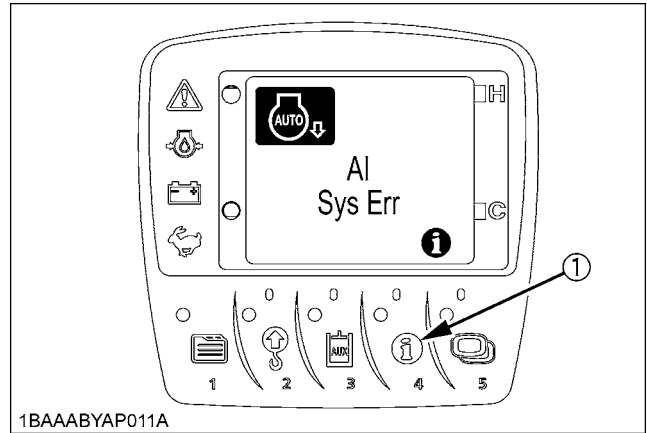

(1) Information switch

A " mark" may appear together with a warning message.

If such occurs, the details can be checked by pressing the information switch.

When contacting your local dealer for repair, notify them of the information provided.

Example;

Press the information switch, and a detail such as shown below appears.

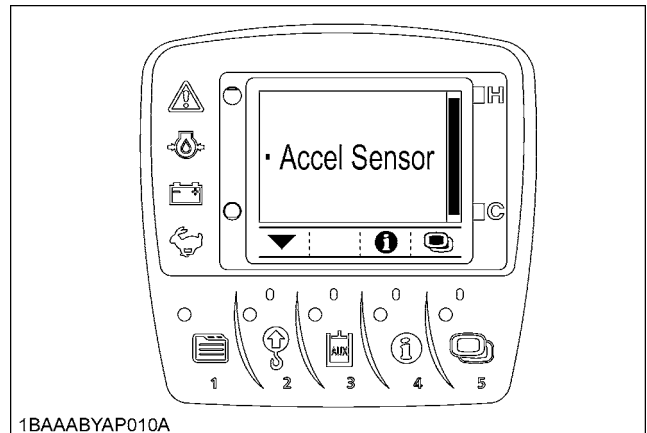

NOTE :

- Press the information switch again, and the display goes back to the previous screen.

User settings

NOTE :

- If you have any question, consult your KUBOTA Dealer.

■ Setting the Clock

1. Turn the starter key to the "RUN" position.

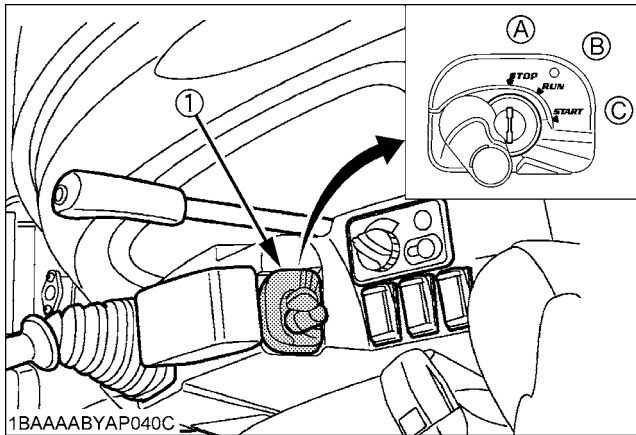

- (1) Starter switch
- (A) STOP
(B) RUN
(C) START

2. Press the switch 1 to make the log record/periodic check/clock set screen appear.

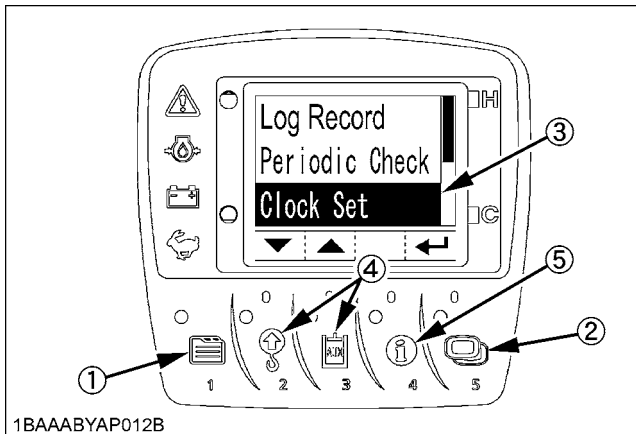

- (1) Switch 1
(2) Switch 5
(3) Cursor
(4) Switch 2 and 3
(5) Switch 4

3. Press the switch 2 twice to move the cursor into position. Then press the save switch 5 to make the following screen appear. By pressing the switch 4, the year, month, day, hour and minute will be selected in this order. Select an item to readjust.

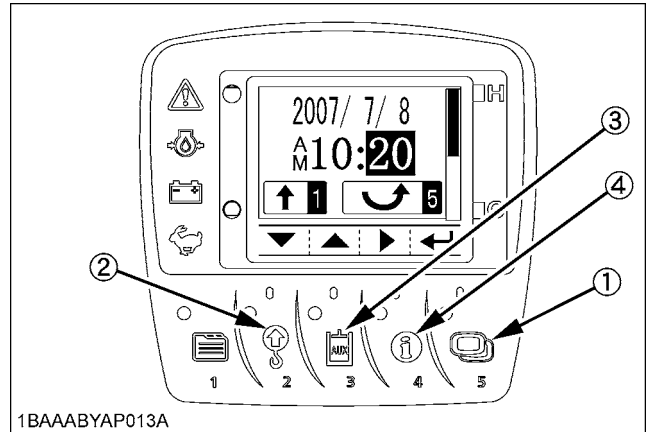

- (1) Switch 5
- (2) Switch 2
- (3) Switch 3
- (4) Switch 4

Press the ▼ switch (Switch 2) and the numeric setting will be smaller.

Press the ▲ switch (Switch 3) and the numeric setting will be larger.

Hold down the ▼ or ▲ switch, and the numeric setting will change quickly.

Press the ► switch (Switch 2), and the year, month, day, hour and minute will be selected in this order.

- Save the new setting with the ← switch (Switch 5). Press this switch 5 again to set the clock.

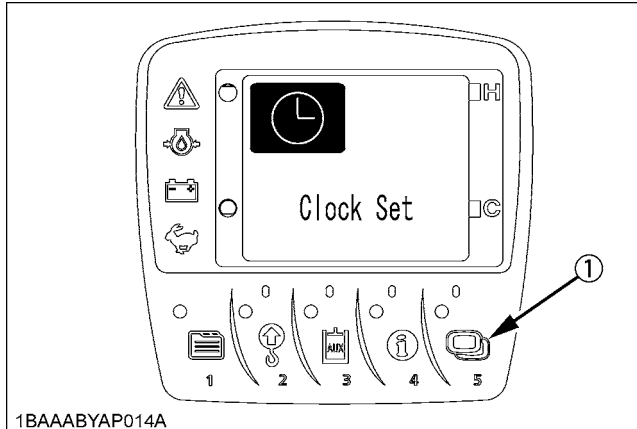

(1) Switch 5

[Status after setting the clock]

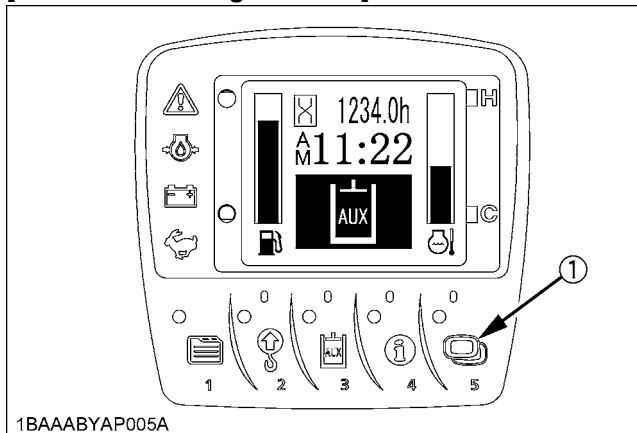

(1) Switch 5

CAUTION

- Be careful not to accidentally press the switch 5 on the clock setting screen. Otherwise the seconds will be set to "00" and the clock will show the wrong time.

NOTE :

- When the user setting switch (Switch 1) is pressed on the clock setting screen, the clock is not readjusted and returns to the pervious menu screen.

IMPORTANT :

- If the clock is interrupted, for example when the battery is disconnected, the following message appears onscreen. Press the switch 5 to set the clock again.

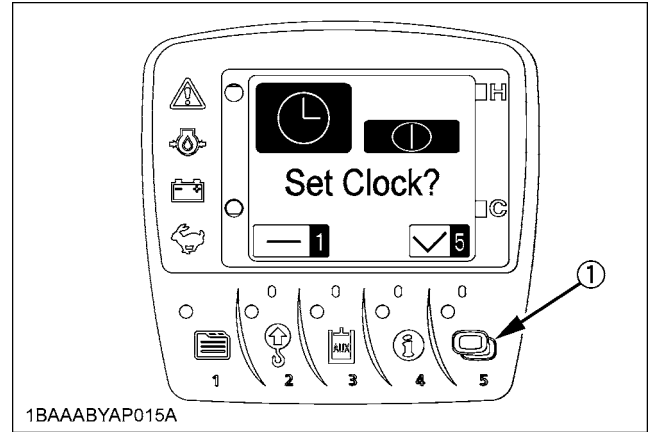

(1) Switch 5

Reordering the year/month/day and Changing the AM/PM System to the 24-hour One

- On the user setting screen, select "Various Settings".

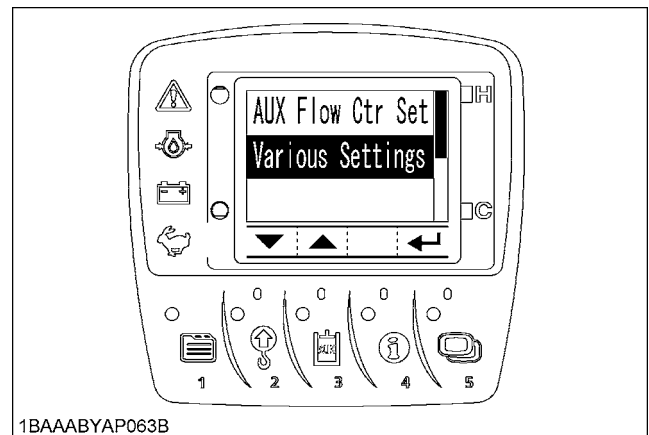

- Select "Calendar/Clock Set" menu screen.

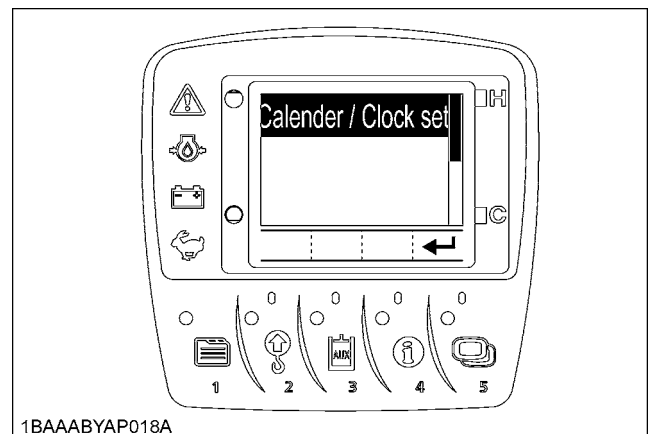

- Press the switch 5 and the following detailed screen shows up.

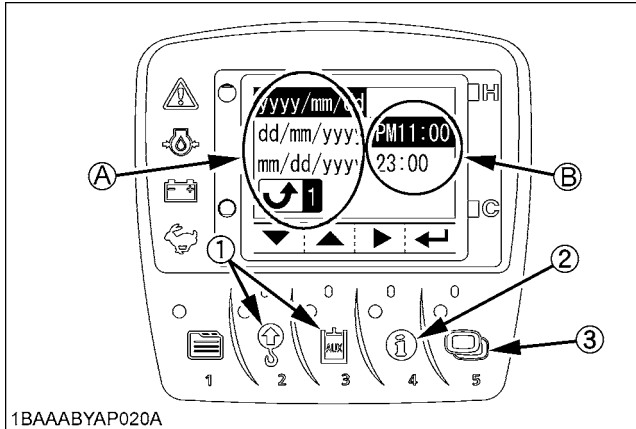

1BAAABYAP020A

- (1) Switch 2 and 3
- (2) Switch 4
- (3) Switch 5
- (A) Year/month/day display
- (B) Clock display

- Using the switch 2 and 3, move up and down the items. The year/month/day on Side (A) will be reordered.
- Using the switch 4, move the cursor to Side (B). Select the "AM/PM" system or the "24-hour" system.
- Press the switch 5, and the new settings will be made.
If the switch 1 is pressed, the previous settings will remain.

NOTE :

- Consult your KUBOTA dealer for details.

■ Log Record

The log record helps you check the last 3-month operating record of the machine. Take the following steps.

- Set the starter key to the "RUN" position.

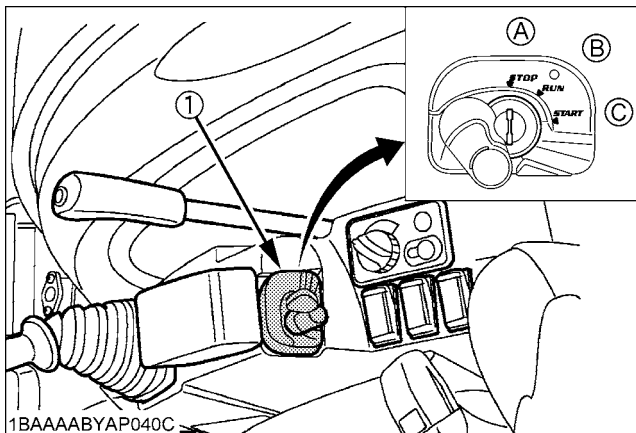

1BAAABYAP040C

- (1) Starter switch
- (A) "STOP"
- (B) "RUN"
- (C) "START"

- Press the switch 1 to make the menu appear onscreen.
- Press the switch 2 and 3 to select the log record. Fix this choice with the ← switch (Switch 5).

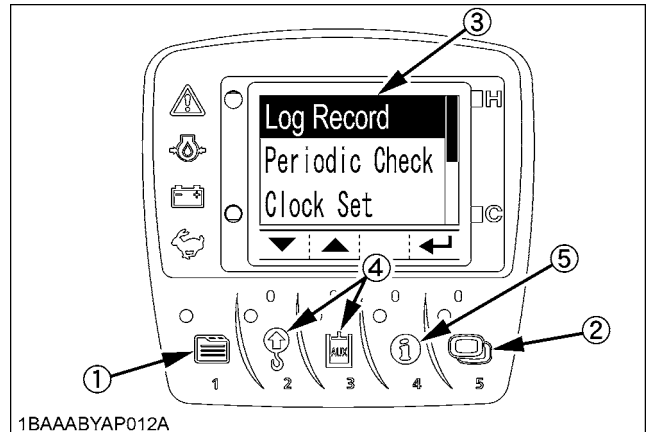

1BAAABYAP012A

- (1) Switch 1
- (2) Switch 5
- (3) Cursor
- (4) Switch 2 and 3
- (5) Switch 4

- Press the switch 5 to make the calendar appear onscreen.
Press the switch 2, and the log records (machine's operating days) for the last month and the month before last (90 days ago) can be reviewed.
The highlighted days indicate when the machine was operated.

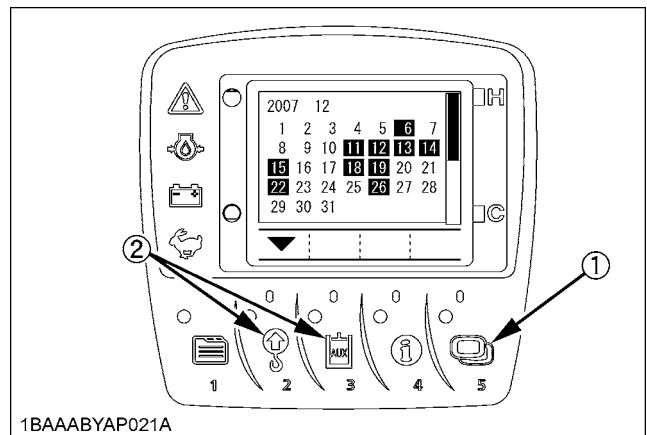

1BAAABYAP021A

- (1) Switch 5
- (2) Switch 2 and 3

IMPORTANT :

- Some days may appear marked with [-] when the log record is unknown because of a new setting of the clock, a disconnection of the battery or other factors.

■ Periodic Check

The following message appears on the LCD display 10 hours before a periodic check.



Press the switch 4 to see the check results.

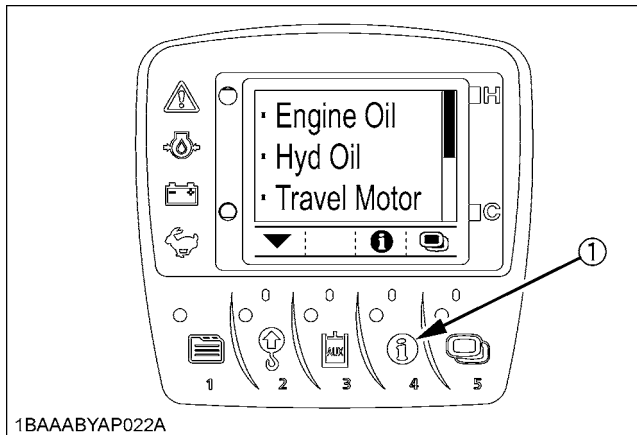

(1) Switch 4

Do the following servicing listed below.

IMPORTANT :

- When the servicing has been completed, turn the key switch ON and OFF 10 times or more and the check screen automatically disappears.
- When the periodic check interval has passed, the message "**Periodic Check Passed**" shows up. Immediately perform the specified servicing.
- The periodic check screen can also be preset to be made to disappear manually only. To do this, it is necessary to select "**Periodic Check**" on the user setting menu.

For make this setting, contact your local dealer.

■ If All the Check Points are not Displayed at a Glance on a Single Screen

1. Press the switch 4.
2. Each time the switch 2 or 3 is pressed, the check points scrolled up or down.

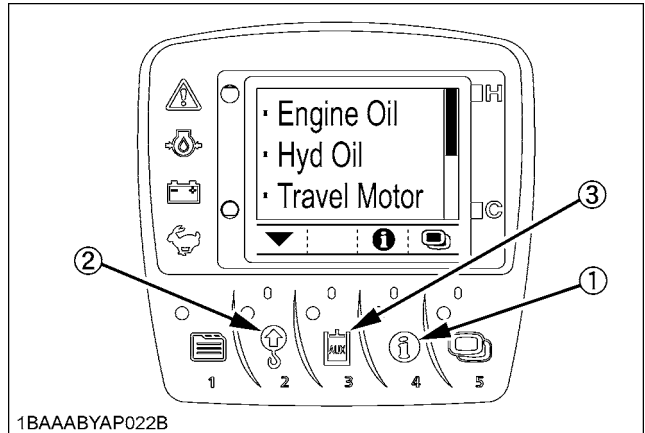

(1) Switch 4

(2) Switch 2

(3) Switch 3

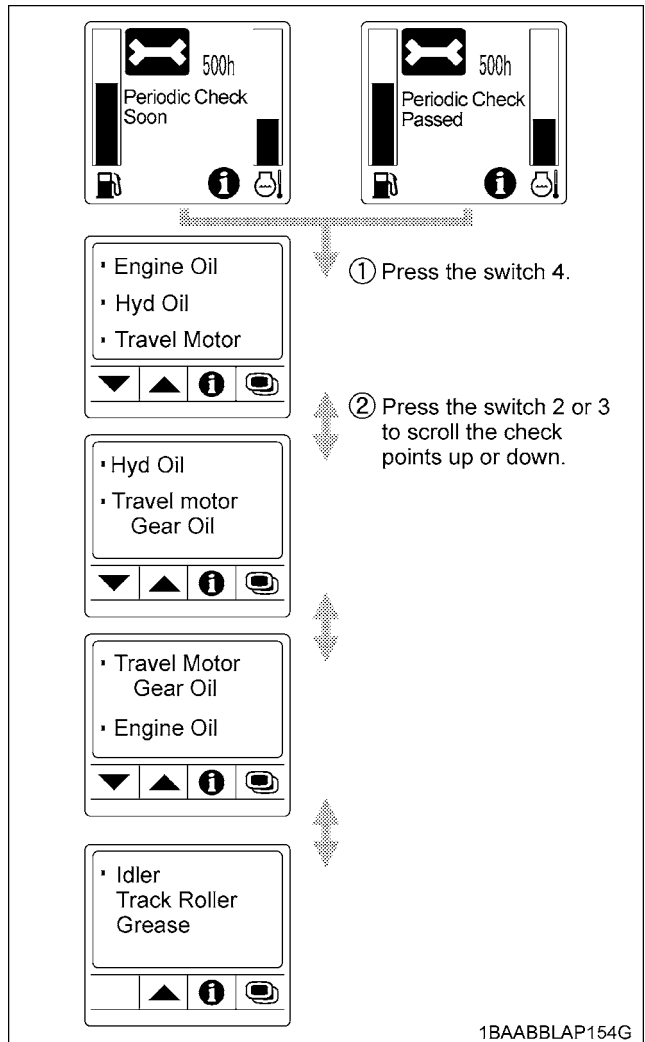

◆ **Service hour meter**

When the hour meter reaches up to the hours circled in the maintenance list below, a message appears. The message shows up as follows.

No.	Check points		Intervals	Hour meter indicator						Consequently	
				50	100	250	500	600	750		1000
1	Engine oil (CF-4)		change			○	○		○	○	every 250 hrs
2	Hydraulic oil									○	every 1000 hrs
3	Air filter element	Outer element	replace							○	every 1000 hrs
		Inner element								○	every 1000 hrs
4	Fuel filter						○			○	every 500 hrs
5	Engine oil filter					○	○		○	○	every 250 hrs
6	Drive unit oil			change	●			○			○
7	Hydraulic return filter cartridge		replace							○	every 1000 hrs
8	Hydraulic suction filter element									○	every 1000 hrs
9	Pilot filter		replace							○	every 1000 hrs
10	Idler, Track roller, grease		-							○	every 2000 hrs
11	Breather filter		replace				○			○	every 500 hrs

● First operation

■ When the Check-up is Completed

When the check-up is completed, perform the following procedure to make the Periodic Check disappear from the screen.

1. The message below appears onscreen to prompt the completion of the check-up.
2. To take a look at the check points, press the information switch. The check points appear onscreen.
3. When the check-up has been completed, press the switch 5. If not, press the switch 1 to go back to the previous screen.

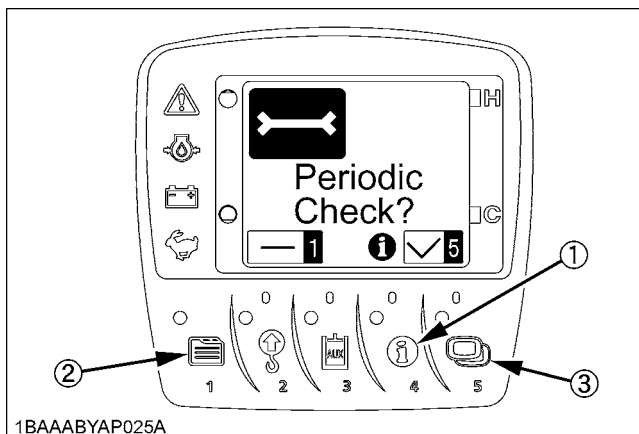

- 1BAAABYAP025A
- (1) Switch 4
 - (2) Switch 1
 - (3) Switch 5

■ Horn Switch

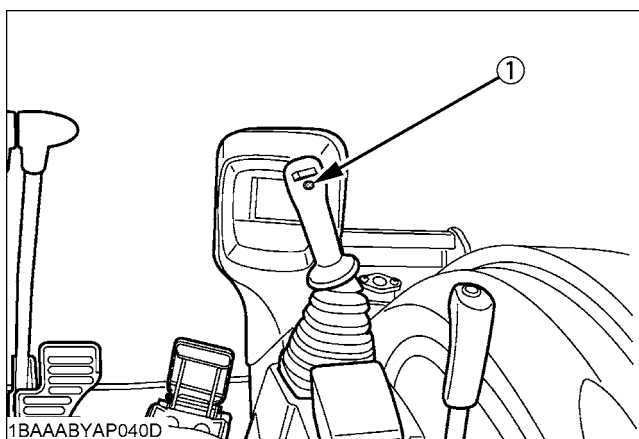

- 1BAAABYAP040D
- (1) Horn switch

■ Working Light Switch

When the starter switch is in position "RUN", the light(s) will be switched on by pressing the switch.

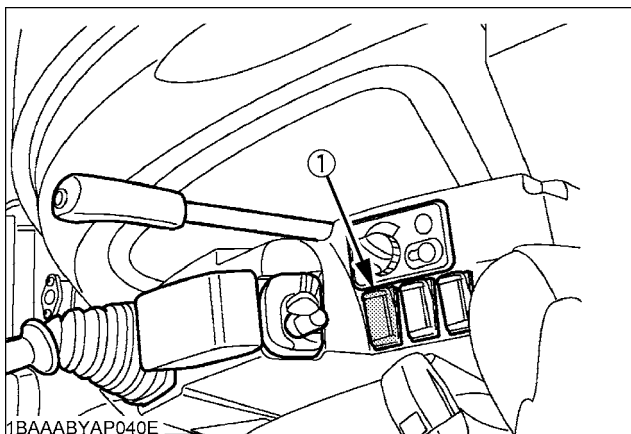

- 1BAAABYAP040E
- (1) Working light switch

◆ Night operation



CAUTION

To avoid personal injury:

- When the working light and CAB light alone do not provide sufficient visibility, prepare additional stationary artificial lighting and observe safety rules for night work.

■ AUX Port Flow Rate Limit Switch

It is possible to freely readjust the actuator's maximum flow rate in the AUX operating mode.

(See "AUX PORT OPERATION" section for detail.)

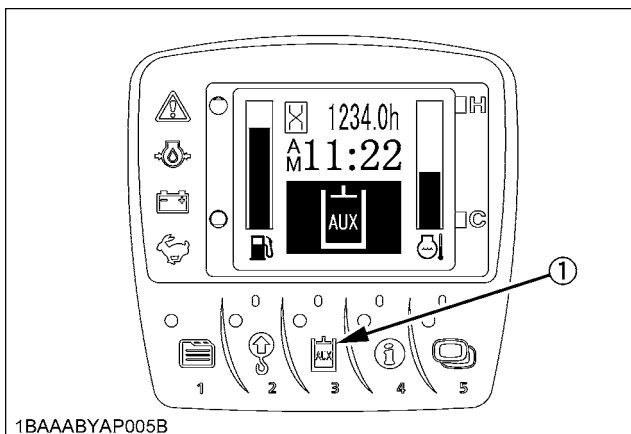

1BAAABYAP005B

- (1) AUX port flow rate limit switch

■ Auto Idle Switch

The switch is used to enable and disable the Auto Idle control.

- **Enable:** Press the Auto Idle switch. When the Auto Idle control is on, the Auto Idle lamp stays on.
- **Disable:** Press the Auto Idle switch once again. Now the Auto Idle control is deactivated (The Auto Idle lamp goes out.)

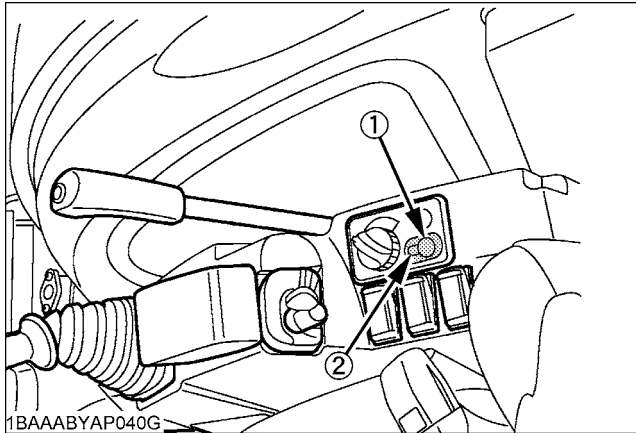

- (1) Auto idle switch
(2) Auto idle lamp

■ Throttle Potentiometer

1. Sit down on the operator's seat and turn the throttle potentiometer clockwise (toward the high speed), and the engine revs up.
2. To stop the engine, turn the throttle potentiometer fully toward the low speed and keep the engine at the idling speed. Then set the starter key to the "STOP" position.

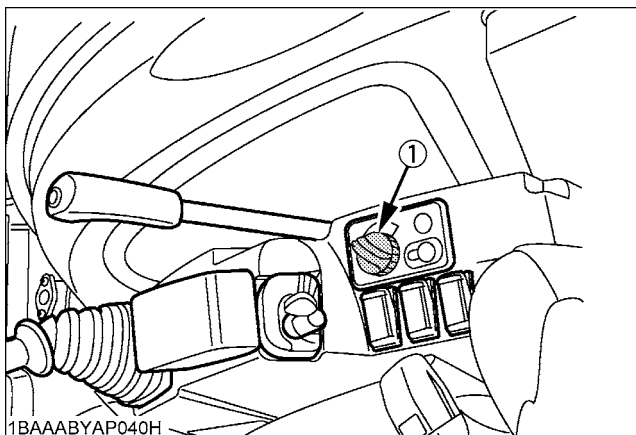



- (1) Throttle potentiometer

■ Travel Speed Switch

Travel speed will increase when this switch is pushed down.

Switching the dual travel speed:

1. Press the travel speed switch. The buzzer beeps twice and the travel speed changes from low to high. The  symbol lights up.
2. Press the travel speed switch again, and the buzzer beeps once and the travel speed changes from high speed to low. The  symbol goes out.

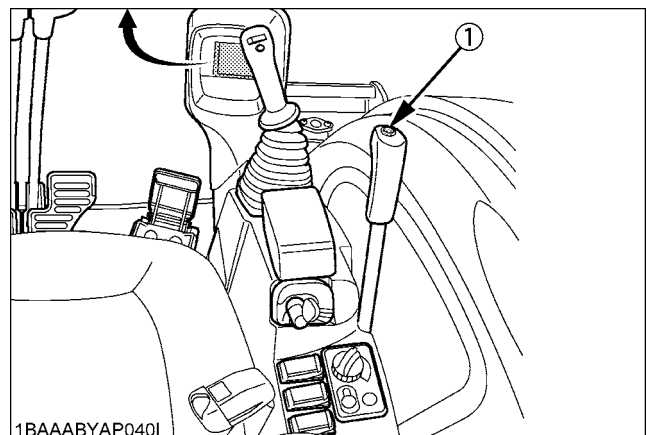
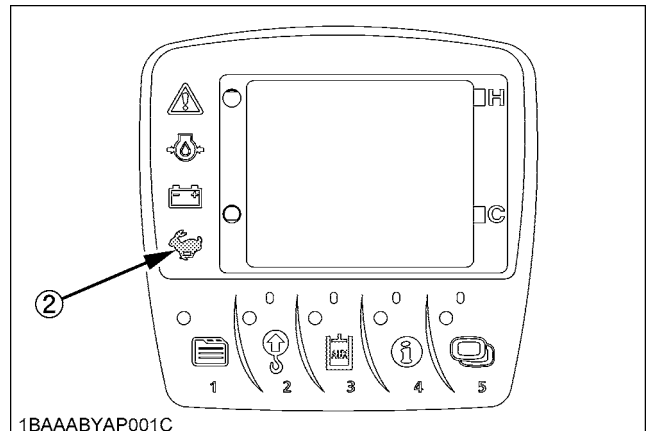

- (1) Travel speed switch
(2) Speed indicator light

NOTE :

- When activating the travel speed switch, it must be pushed down completely.
- Each time the travel speed switch is pressed, the travel speed is switched between low and high.

IMPORTANT :

- The travel speed automatically changes into first speed (low speed) when the drive resistance increases while traveling second speed (high speed). Thereafter, when the resistance decreases, it returns to second speed.
- If the tracks are clogged with sand or gravel while working on soft ground, lift up the track with the help of the boom, arm and bucket and dozer blade, and let the track rotate to remove the sand and gravel.

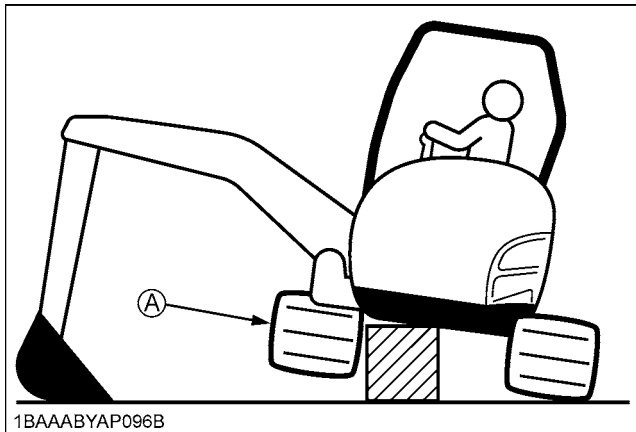

(A) "Rotate to remove sand and gravel"



WARNING

- Do not push the dozer control lever into the float position as this will cause the machine to suddenly drop.



DANGER

To avoid serious injury or death:

- Do not work under the machine in this condition.

CAB TYPE MACHINES

■ Wiper/Washer Switch

To engage the wiper, turn on the switch for the wiper when the starter key is in the "RUN" position. A further push on the switch will activate the washer system. Even when the wiper switch is in the "OFF" position, the washer switch functions if it is pressed.

- Do not activate the washer switch if the tank for the cleaning fluid is empty; the pump can be damaged.
- Do not activate the wiper switch if the window is dry. In this case, make sure that cleaning fluid is applied to the pane before activating the wiper.
- In frosty conditions, make sure that the wiper blade is not frozen to the glass before switching-on. The motor can be damaged if the wiper system is used under such conditions.

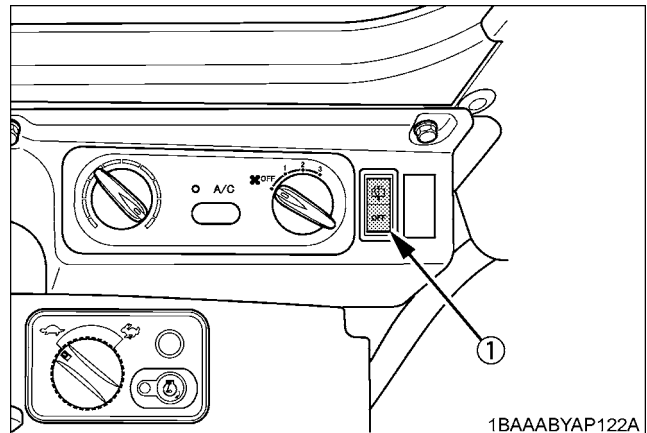

(1) Wiper switch

■ Interior Lamp

To turn on the interior lamp, set the interior lamp switch to the "ON" positions.

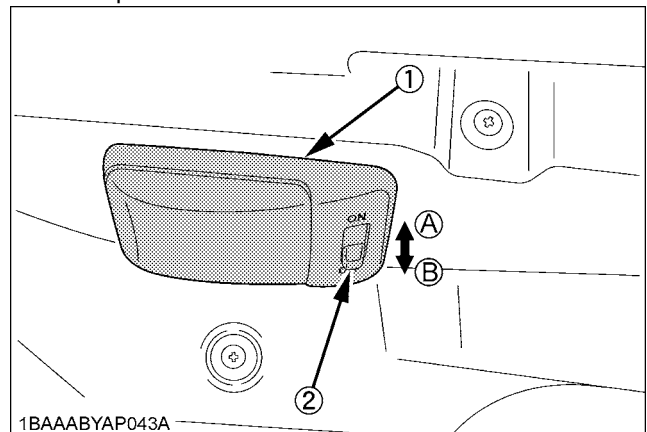

(1) Interior lamp (A) "ON"
 (2) Interior lamp switch (B) "OFF"

■ Cab Light Switch

To turn on the cab light, set the starter switch to the "RUN" position and then the cab light switch to the "ON" position, respectively.

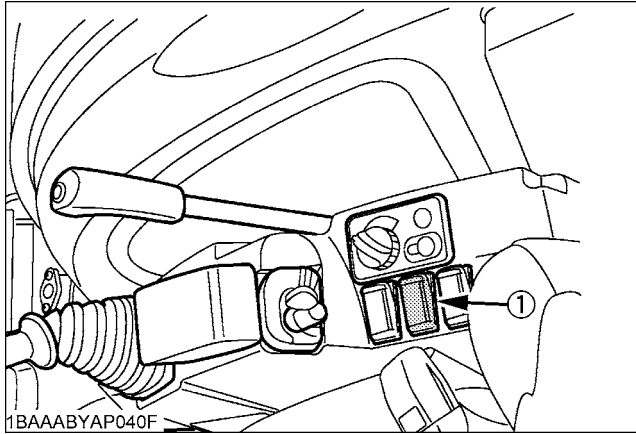

(1) Cab light switch

■ Heater Switch

Turn the starter switch to the "RUN" position and turn the heater switch clockwise, the heater fan will be activated and the cabin will start to warm up. The heater has three position.

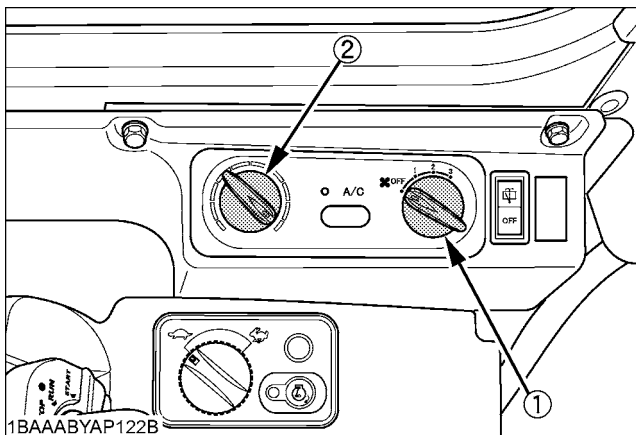

(1) Heater switch
(2) Temperature control dial

IMPORTANT :

- During summer, turn the heater valve clockwise to close the valve.

■ Opening/Closing of CAB Door

1. Unlock the CAB door and pull the knob. Open the CAB door fully until fixed into place.
2. To close the CAB door, push the release lever down and close the door.

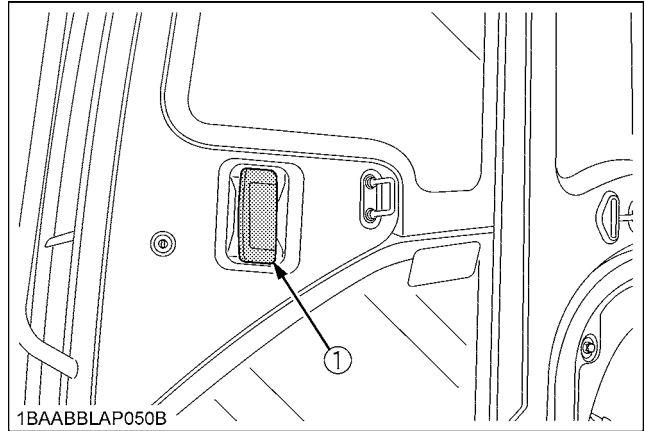

(1) Door knob (outside)

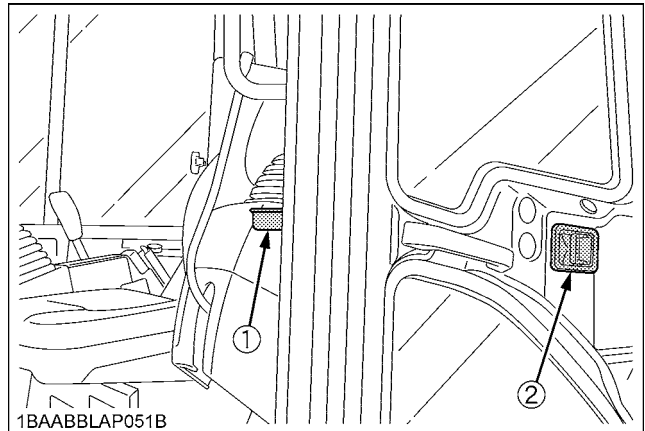

(1) Release lever
(2) Door knob (inside)

3. When leaving the excavator, always lock the door.

■ Opening/Closing of Front CAB Window



CAUTION

To avoid personal injury:

- Keep hands and feet away from the area between front window and CAB frame. Otherwise the operator risks serious pinching or crushing injuries.
- Other persons should stay clear when opening the window.

To open and close the front window, take the steps below.

1. Push the lock levers beside grip.

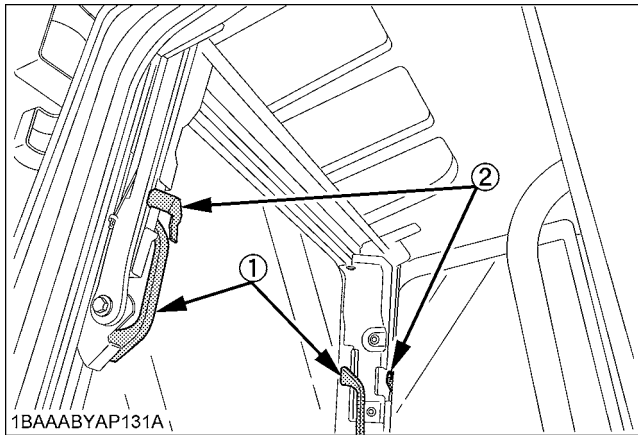

- (1) Grip
(2) Lock lever

2. Hold the grips tightly with both hands. Pull the grip slightly upward and toward yourself to let the windshield slide inward.
3. Pull the windshield all the way to the lock at the back of CAB.
4. To close the window, take the reverse steps 3, 2 and 1.

■ Opening/Closing of Side CAB Window

1. Pull the grip to release the lock and pull side window open to the rear or to the front.
2. To close the side window, slide it forward or backward until the lock snaps in at the window frame.

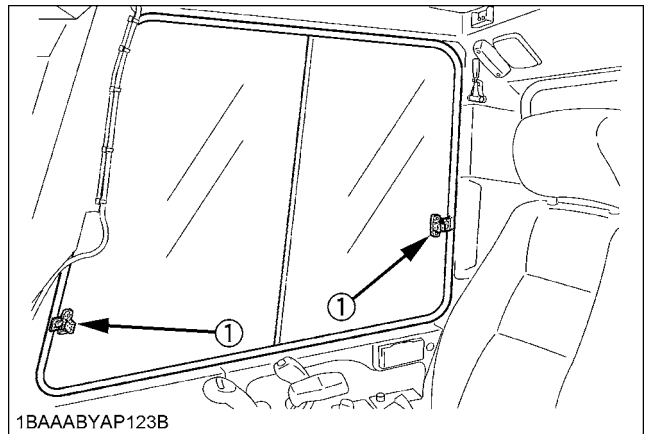

- (1) Grip

■ Emergency Hammer



CAUTION

To avoid personal injury:

- When breaking the window pane, close your eyes and cover them with an arm.

The emergency hammer is for breaking a window pane in order to quick escape from the cab, should the window not open.

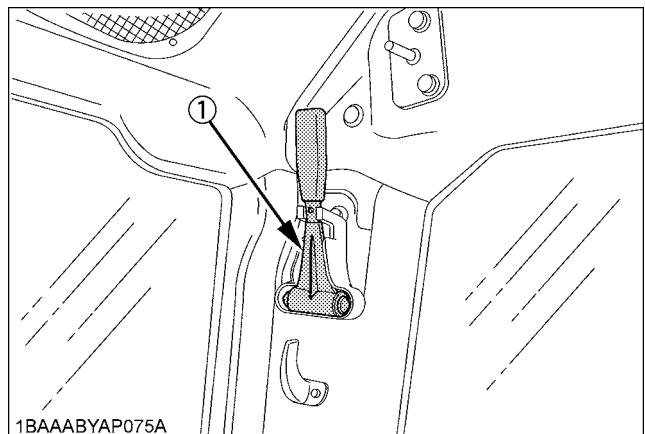

- (1) Emergency hammer

AIR CONDITIONER

■ Air Flow

Air in the CAB and fresh air introduced into the CAB flow as shown in the figure. Adjust the five air outlet ports to obtain the desired condition.

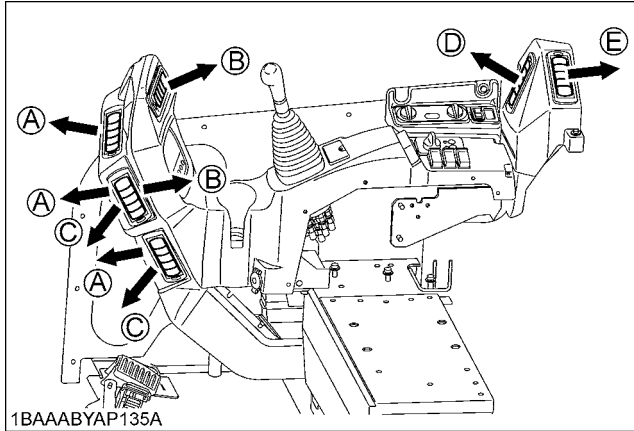

- (A) "FRONT WINDOW"
- (B) "CHEST AREA"
- (C) "FOOT AREA"
- (D) "SIDE WINDOW"
- (E) "BACKWARD"

Position the inlet selector lever to the desired position.

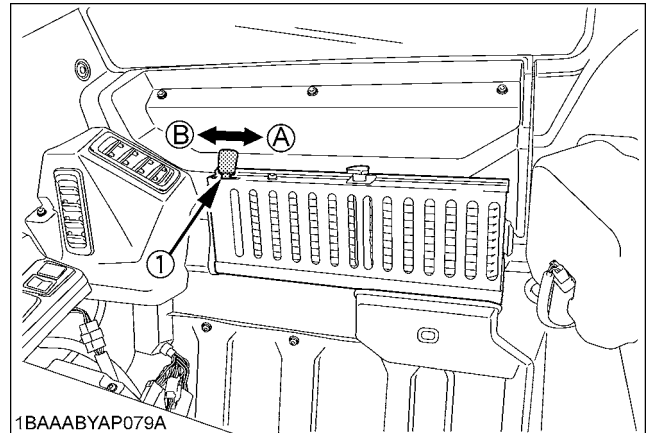

- (1) Inlet selector lever (A) "FRESH AIR INLET" position
- (B) "INNER AIR RECIRCULATION" position

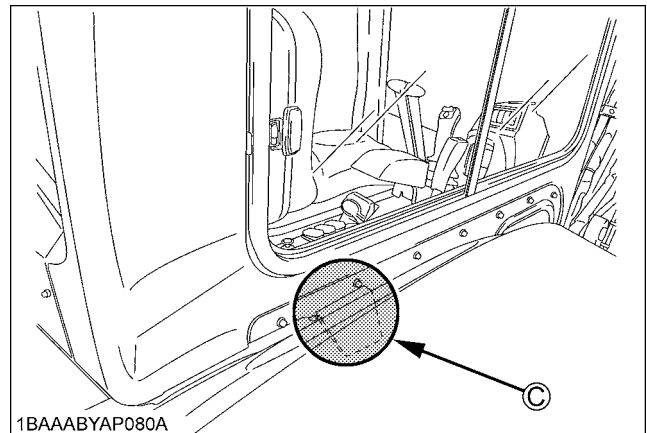

- (C) "FRESH AIR INLET"

IMPORTANT :

- Do not allow water to enter the fresh air port while washing the excavator.

■ Air Control Vent

◆ Front air outlet

The front air outlets can be independently adjusted as required. To defrost the windshield, rotate the outlets toward the windshield.

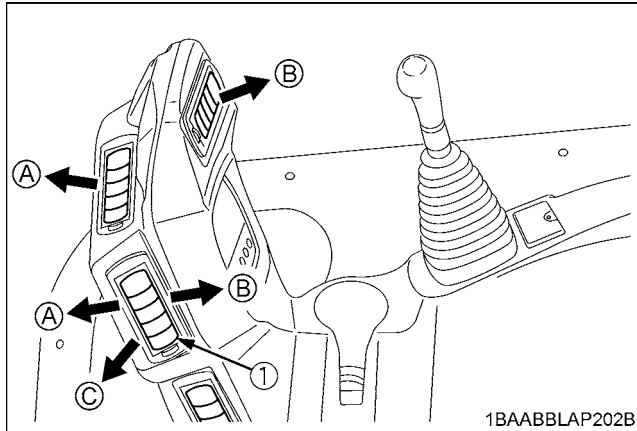

(1) Front air outlet
 (A) "FRONT WINDOW"
 (B) "CLOSED"
 (C) "FOOT AREA"

■ Control Panel

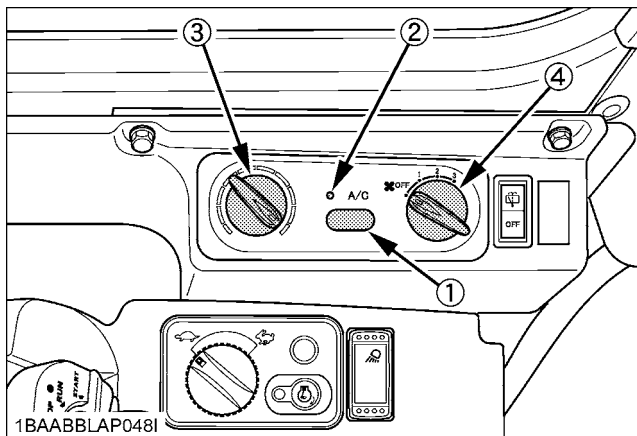

(1) Air conditioner switch
 (2) Indicator light
 (3) Temperature control dial
 (4) Blower switch

◆ Air Conditioner Switch and Indicator Light

Push this switch to activate the air conditioner. An indicator light will light up when the switch is set to "ON". Push switch again to turn air conditioner off, the indicator light will go off.

◆ Temperature Control Dial

Set this dial at the desired position to obtain the desired air temperature. Turn the dial to the right to obtain cooler air. Turn it to the left to obtain warmer air.

◆ Blower Switch

Air volume can be changed in three steps. At the "3" position, the largest air volume is obtained.

■ Operation

◆ Heating

1. Adjust the blower (1/2/3) switch and the temperature control dial to achieve the desired temperature level.

◆ Dehumidifying-heating

1. Press and turn on the air-conditioner switch.
 2. Turn on the blower (1/2/3) switch.
 3. Adjust the temperature control dial to the "COOL" or an intermediate position to achieve the desired temperature level.

NOTE :

● Be sure to close the door while the air conditioner is ON otherwise, you may overload the compressor.

◆ Cooling

1. Press and turn on the air-conditioner switch.
 2. Turn on the blower (1/2/3) switch.
 3. Adjust the temperature control dial to the "COOL" or an intermediate position to achieve the desired temperature level.

◆ Defrosting or demisting

To defrost or demist the windshield, take the following steps.

1. Open the front air outlet and direct it to the windshield.
 2. Set the blower switch and the temperature control dial to the "3" and "WARM" (leftmost) positions, respectively.

HANDLING THE SAFETY DEVICES

■ Pilot Control Lock Lever

⚠ CAUTION

● When the excavator is not used or left unattended, be sure to place the pilot control lock lever in position "Locked".

The pilot control lock lever is located on the left side.

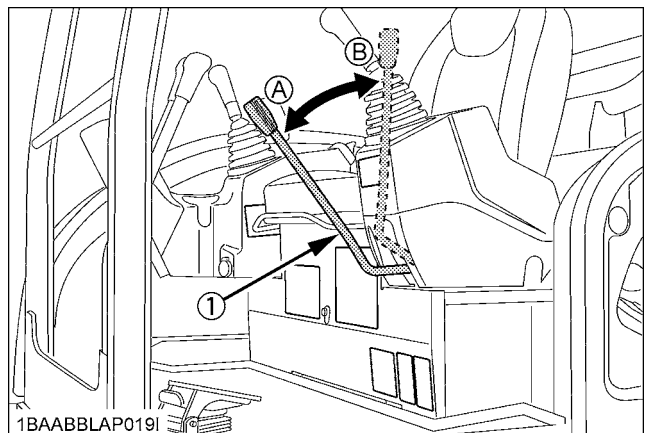

(1) Pilot control lock lever
 (A) "Unlock"
 (B) "Locked"

OPERATION OF THE ENGINE



CAUTION

To avoid personal injury:

- Read "SAFE OPERATION" at the beginning of this operator's manual.
- Obey the danger, warning and caution labels on the excavator.
- To avoid the danger of exhaust fume poisoning, do not operate the machine in a closed building without proper ventilation.
- Always start the engine from the operator's seat. Do not start the engine while standing next to the excavator. Before starting the engine, sound the horn to get the attention of persons standing nearby.

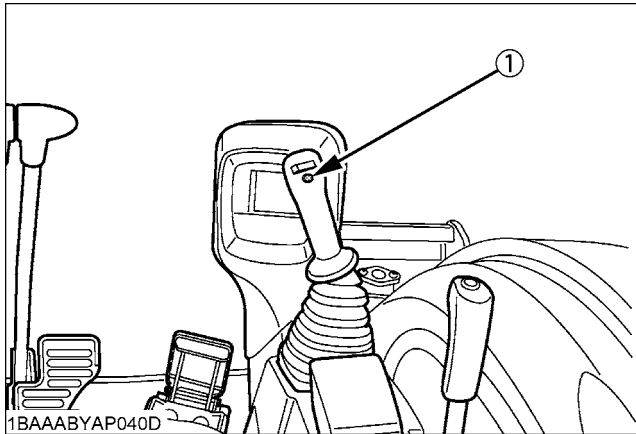

(1) Horn switch

IMPORTANT :

- Do not use starting fluid or ether.
- In order not to overload the battery and starter, avoid engaging the starter for more than 10 sec.
- If the engine does not start in 10 sec., please wait 20 sec. or more, before attempting to restart.

STARTING THE ENGINE



CAUTION

To avoid personal injury:

- The operator should not depend solely on the warning lamps, but should always conduct the routine checks (see "MAINTENANCE").

Start the engine in the following manner:

1. Before starting the engine, make sure that all control levers are in the neutral positions.

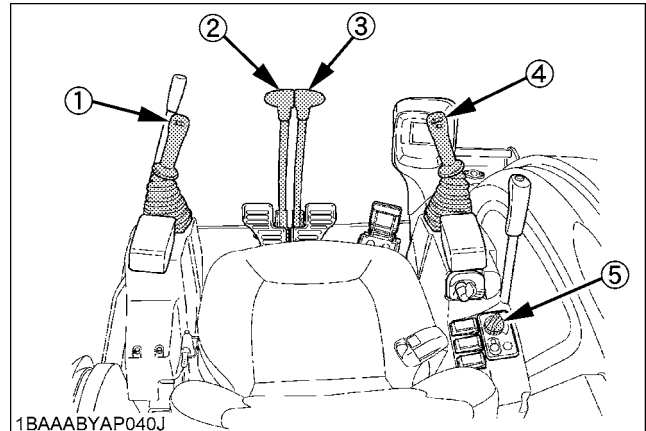

- (1) Attachment control lever (left)
- (2) Drive lever (left)
- (3) Drive lever (right)
- (4) Attachment control lever (right)
- (5) Throttle potentiometer

2. Pull the lock lever all the way back. (lock position)
3. Put the throttle potentiometer in the middle between "🐢" and "🐇" symbols. The switch for Auto Idle control is in the OFF position. (See "AUTO IDLE (AI) OPERATION" in the Excavator operation.)

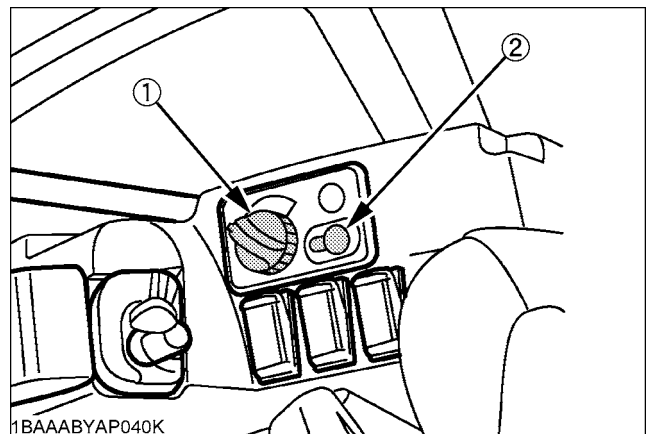

- (1) Throttle potentiometer
- (2) Switch for Auto Idle control

- Set the starter key to the "RUN" position. Hold the key at this position until the "00" mark on the display panel disappears.

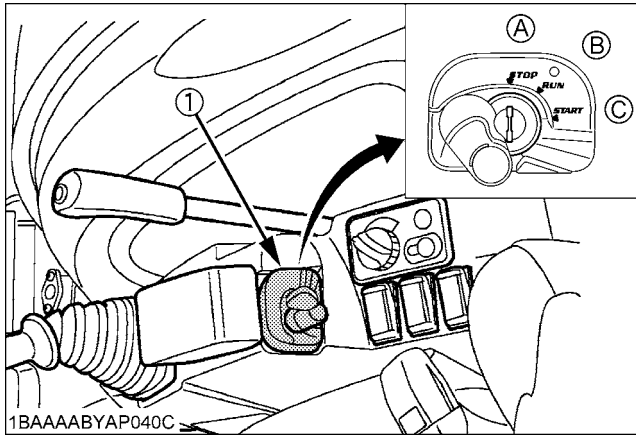

(1) Starter switch
 (A) "STOP"
 (B) "RUN"
 (C) "START"

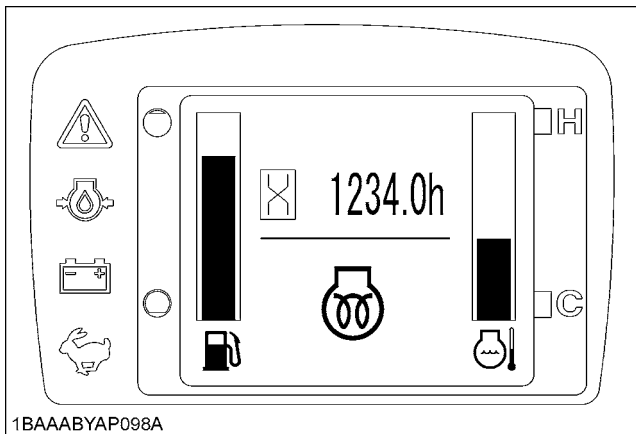

- Now make sure the "⚠" and "🔋" marks appear onscreen. If not, the system has malfunctioned. Contact your local dealer for repairs.
- Turn the key to the position "START" and release after the engine has started.
- Check if all warning lamps have gone out. Should a warning lamp still be lit up, stop the engine then remove the key and check for the cause.

IMPORTANT :

- The starter motor draws a large current. Avoid running it longer than 10 seconds continuously. If the engine fails to start within 10 seconds, set the key to the "STOP" position, wait for 20 seconds or longer, and repeat the above steps 5 thru 8.
- If the battery is dead and must be connected to another battery with jumper cable, be sure to use a 12V battery. Never use a 24V batteries.

NOTE :

- If you keep the pilot control lock lever at "UNLOCK" and try to start the engine, "Up Lever Lock" appears on the meter panel and the engine cannot be started. Before starting the engine, make sure the pilot control lock lever is set at the "LOCK" position.



- When the engine starts, the meter may momentarily turn off and a beep may sound. This is not a problem.

STARTING THE ENGINE UNDER COLD CONDITIONS

CAUTION

To avoid personal injury:

- Make sure that the lock lever is in the lock position during warm up.

Start the engine in the following manner;

- Make sure the auto idle switch is at the "OFF" position (lamp off).
- Pull the lock lever all the way back. (Lock position)
- Insert the starter key into the starter switch.
- Turn the throttle potentiometer toward "⚡" (high speed) position.
- Set the starter key to the "RUN" position. Hold the key at this position until the "00" mark on the display panel disappears.
- Turn the starter key to the "START" position.
- Once the engine starts, release your hand from the key. The key will return back to the "RUN" position.
- If the engine fails to start, set the starter key to the "STOP" position, and repeat the above steps 5 thru 7.

IMPORTANT :

- Let the engine warm up after start-up for approx. 10 minutes under no load conditions. If the hydraulic fluid temperature is too low, the operation will be affected. Do not operate the excavator under full load until the engine has sufficiently warmed up.

STARTING WITH AN AUXILIARY BATTERY



CAUTION

To avoid personal injury:

- Battery gases can explode. Do not smoke and keep sparks and flames away.
- Do not start the engine with an auxiliary battery if excavator battery is frozen.
- Do not connect the black jumper cable to the negative (-) terminal of the excavator battery.

■ Observe Following Guidelines when Starting with an Auxiliary Battery

1. Bring the helping machine with the same battery voltage as near as possible to the excavator. THE MACHINES MUST NOT COME IN CONTACT WITH EACH OTHER.
2. Bring the levers and pedal of both vehicles in the neutral position and put the lock lever in the "Lock" position.
3. Wear eye protection and rubber gloves.
4. Open the side cover. (See "Opening / closing of the Side Cover" in "MAINTENANCE" section.)
5. Ensure the vent caps are securely in place (if equipped).
6. Cover the battery opening with a cloth. Make sure that the cloth does not touch the battery terminals.
7. Connect the terminal of the red jumper cable with the plus (+) terminal of the low battery and connect the other end of the cable to the plus (+) terminal of the auxiliary battery.
8. Connect the black negative cable to the minus (-) terminal of the auxiliary battery.
9. Connect the other end of the black cable (coming from the auxiliary battery) to the excavator frame as far away as possible from the low battery.
10. Start the engine of the helping machine and let it run for a while. Start the excavator with the low battery.
11. Disconnect the jumper cables in the reverse sequence (Steps 8, 7, 6).

12. Remove the cloth and replace the vent caps.

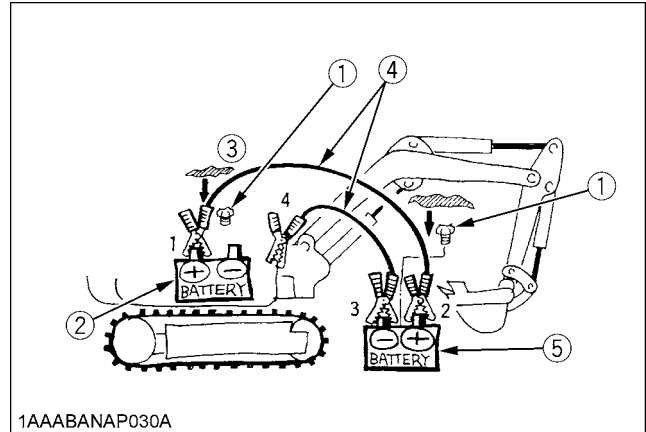

- (1) Lay a damp rag over the vent caps
- (2) Low battery
- (3) Put a cloth over the battery openings
- (4) Jumper cables
- (5) Auxiliary battery

IMPORTANT :

- This excavator has a negative (-) ground 12 Volt starting system.
- Use only the same voltage when using an auxiliary battery.
- Using a higher voltage will cause serious damage to the electrical system. When using an auxiliary battery, only the compatible (same) voltage is permissible.

CHECK POINTS AFTER STARTING THE ENGINE

After starting the engine, but before starting operation, check the following points:

- Put the throttle potentiometer in the middle between "🐷" and "🐷" symbols and let the engine idle for approx. five minutes. This allows the engine lubricant to warm up and penetrate every part of the engine.
 - Once the engine has warmed up, check:
 - the warning lamp "Engine oil pressure" has gone out.
 - the warning lamp "Battery charge" goes out when engine speed is increased.
 - the color of the exhaust is normal and no abnormal noises or vibrations are heard or felt.
 - no fluid is leaking from pipes or hoses.
- ◆ **Should any following conditions occur, stop the engine immediately.**
- The engine rpm's increases or decreases suddenly.
 - Sudden abnormal noises are heard.
 - Exhaust is black.
 - Warning lamp for engine oil lights up during operation.

IMPORTANT :

- In these cases, the excavator must be checked and serviced by your local the KUBOTA dealer.

STOPPING THE ENGINE



WARNING

To avoid personal injury or death:

- Do not keep the bucket or dozer in an elevated position, as a person could accidentally touch the levers and cause serious accidents.
- Place the bucket and dozer on the ground.
 - After slowing the engine to idle, turn the key to "STOP".
 - Remove the key.
 - Pull the lock lever to "LOCK" position.

■ Engine Stop Button



CAUTION

To avoid personal injury:

- Keep hands away from rotating parts.

IMPORTANT :

- Be sure to return the stop button to former position after the engine stops.

The engine stops when the starter key is turned off. If the engine does not stop, pull the stop button to stop the engine.

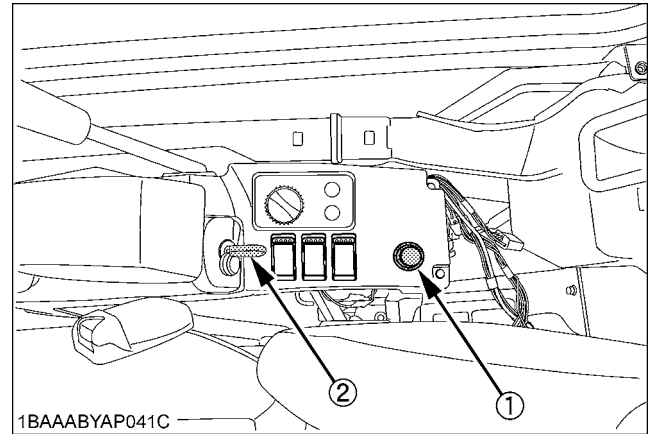

- (1) Stop button
(2) Starter key

■ Precautions in case of Overheat



CAUTION

To avoid personal injury:

- Do not open the radiator cap during operation or just after shut-down. Otherwise, steam or very hot coolant may gush out, getting you scalded. Make sure the radiator has cooled down enough before opening its cap.

If by any chance the coolant temperature rises close to or above the boiling point ("H" on the water temperature gauge) (overheat condition), take the following steps.

- Stop operating the machine.
(Relieve the engine of any load.)
- Do not shut off the engine suddenly. Before shutting off the engine, keep it idling under no load for about 5 minutes.
- Stay away from the engine or overflow for 10 minutes or until the steam overflow stops.
- Be sure that there is no danger of getting scalded. Pinpoint and remove the cause of overheat, referring to the "TROUBLESHOOTING" section. Once the issue is resolved, the engine may be restarted.

EXCAVATOR OPERATION

RUNNING-IN OF THE NEW EXCAVATOR

The operation and care of the new excavator influences its life span. Your new excavator has been carefully checked and tested before leaving the factory. In spite of this, all movable components must run-in during the first 50 work hours. Do not work with full rpm's and full loads during this period. It is very important to run-in your excavator properly in order to achieve its full performance and longevity. During the running-in, the following points should be adhered to in all cases.

■ Do not Work with Full Engine Rpm's or Full Loads during the First 50 Working Hours

- Let the engine warm up sufficiently in the cold season.
- Do not let the engine rev-up more than necessary.

■ Oil Change in the Run-in Stage

The lubrication oil plays a specific and important role during the run-in phase of the excavator. The numerous movable parts are not yet run-in, so many fine metal particles are generated, which can cause damage and shorten the life of many components. Pay attention to the oil-change intervals and complete them sooner than later. See "REGULAR CHECKS AND MAINTENANCE WORK" section for more details on the oil-change intervals.

■ Adjusting the Operator's Seat



CAUTION

To avoid personal injury:

- Make sure that the seat is completely secured after each adjustment.

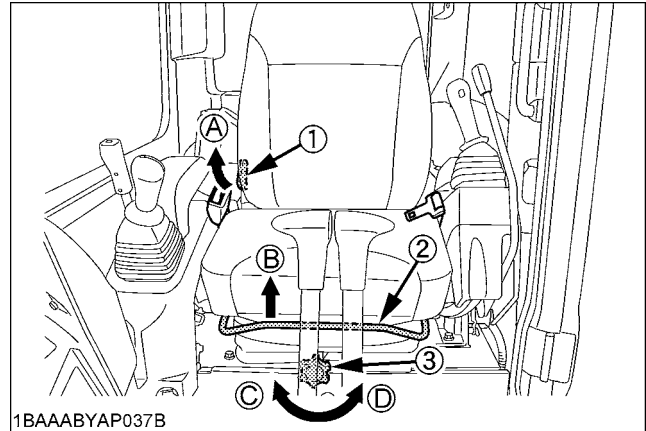

- | | |
|--------------------------------|---------------------------|
| (1) Backrest tilt adjust lever | (A) "UNLOCK" |
| (2) Travel adjust lever | (B) "UNLOCK" |
| (3) Weight adjust lever | (C) "TO INCREASE TENSION" |
| | (D) "TO DECREASE TENSION" |

◆ Tilt adjustment

Pull the backrest tilt adjust lever in the direction of [A] and move the backrest to the desired angle.

◆ Travel adjustment

Pull the travel adjust lever in the direction of [B] and slide the seat backward or forward, as required. The seat will lock in position when the lever is released.

◆ Weight adjustment

Turn the weight adjust lever to achieve the optimum suspension setting.

◆ Height adjustment

Lift the seat to the desired height of the three available positions. Adjust the seat to the desired position after lifting the seat to the highest position in the case of lowering the seat.

■ Seat Belt

! WARNING

To avoid personal injury or death:

- Always use the seat belt with a ROPS/FOPS protection structure. Adjust the seat to the optimal position and buckle up.

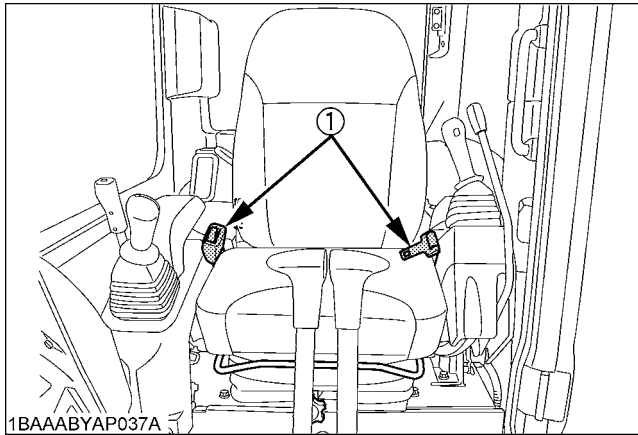

(1) Seat belt

STARTING

! CAUTION

To avoid personal injury:

- No persons, other than those who have read and understand this manual and who are familiar with the excavator, should be allowed to use the excavator.
- Do not allow any person other than the operator to ride on the excavator.
- When operating, keep hands and body inside of the ROPS/FOPS protective.
- Do not touch the control levers and the pedals from outside the cab while the engine running.

■ Pilot Control Lock Lever

! CAUTION

To avoid personal injury:

- To avoid injuries, check safety aspects all around the excavator.

NOTE :

- If the pilot control lock lever is pulled down, the engine will fail to start.

Don't attempt to start the machine with the Pilot Control Lock Lever in the down position (A), if attempt is made the following message appears on the LCD display.



1BAABBLAP142B

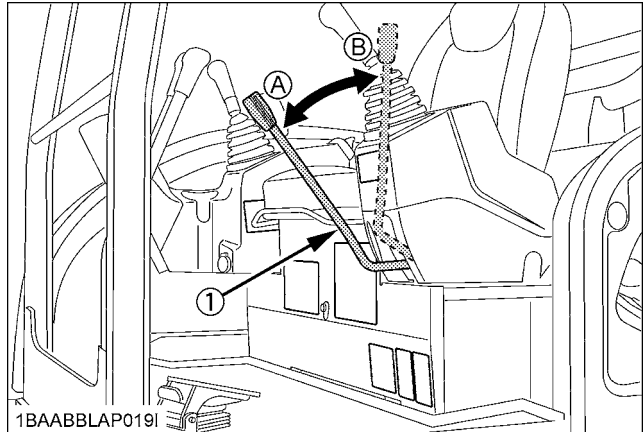

(1) Pilot control lock lever

(A) "Unlock"

(B) "Locked"

IMPORTANT :

- Always pull pilot control lock lever up to "Locked" position (B) when you stop the engine or leave the operating structure.

DRIVING



WARNING

To avoid personal injury or death:

- Before starting the engine, make sure that no one is near the excavator.
- Before operating the excavator, check the track direction. (Front idler and dozer blade to the front of the excavator).

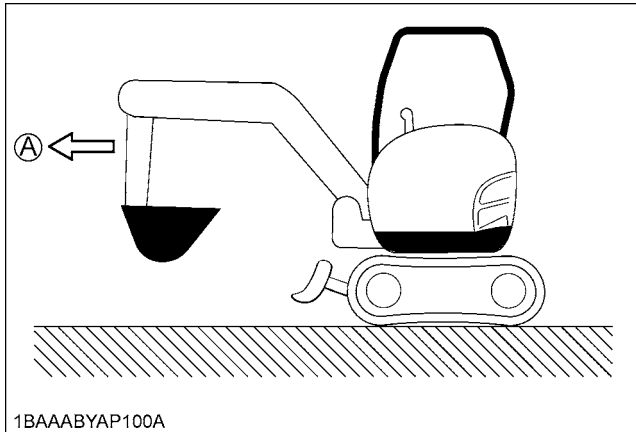

(A) "Front of the excavator"

- Use extra caution when traveling across a slope or working sideways on a slope.

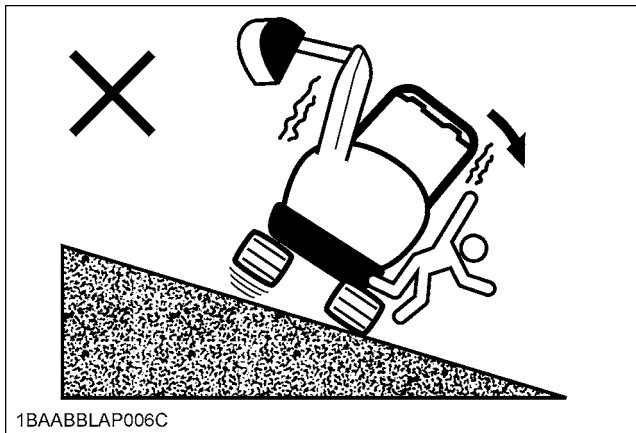

- Recommended technique for working on a slope.

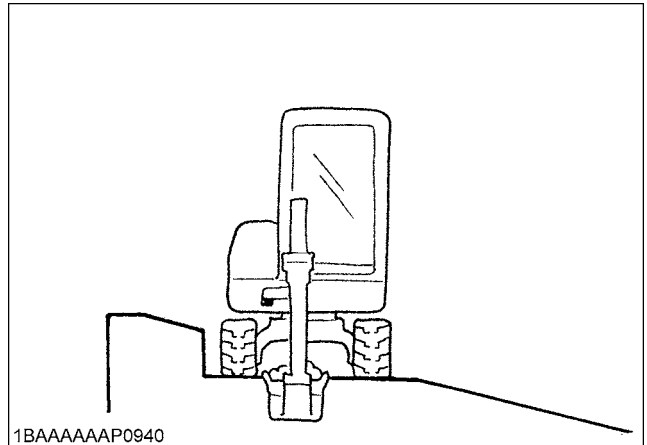

1. Adjust the engine speed from idling to an intermediate speed.
2. Unlock the pilot control lock lever and pull in the bucket and hold the bucket about 20 to 40 cm above the ground.

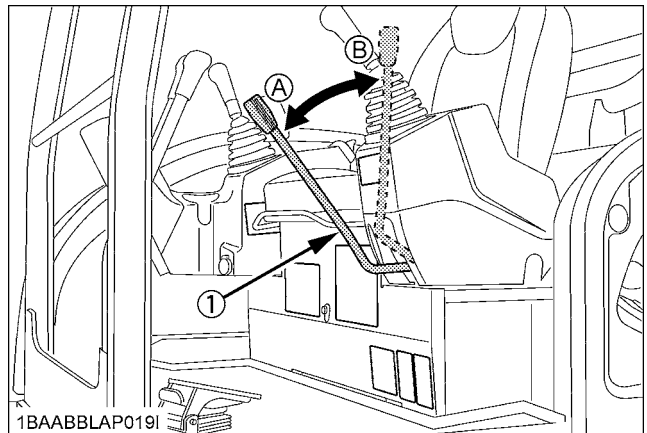

- (1) Pilot control lock lever (A) "Unlock" (B) "Locked"

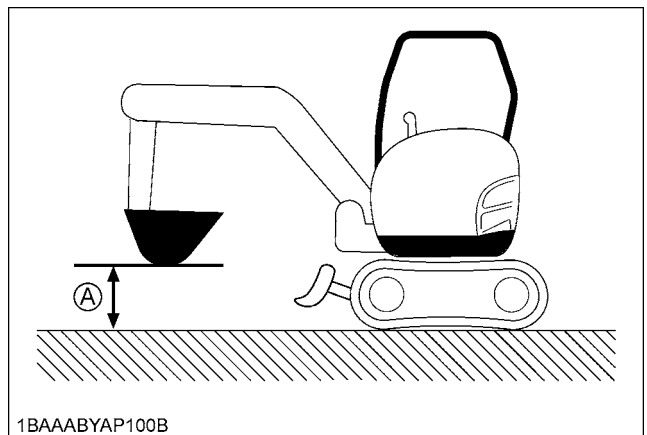

(A) 20 to 40 cm

3. Activate the dozer control lever to raise the dozer.

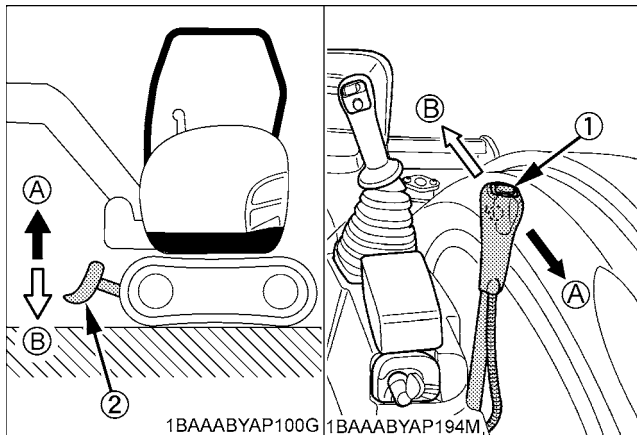

(1) Dozer control lever (A) "Raise" (B) "Lower"

■ Drive Levers(Right,Left)

WARNING

To avoid personal injury or death:

- When driving the excavator keep the dozer blade in front. To move the excavator forward, move the drive levers to (A) and to move in reverse, move the drive levers to (B) with dozer blade in front. If the dozer blade is behind operator station, then the controls are reversed, moving the excavator forward will require (B) and moving the excavator backwards will require (A), but this is not recommended.

Pushing the drive levers forward, moves the excavator forwards, and vice-versa. The front of the excavator is the side where the dozer is located; the drive sprocket is in the rear of the excavator.

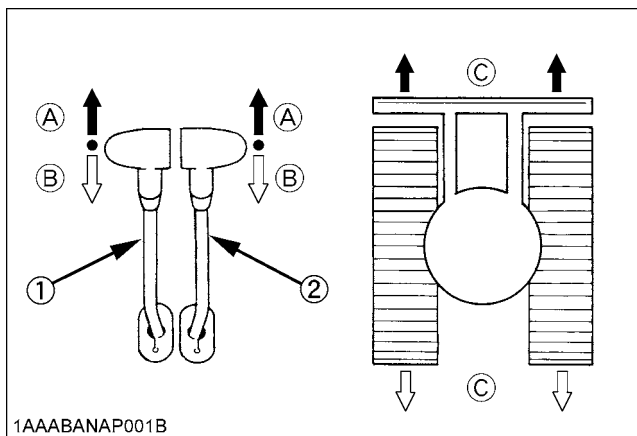

(1) Drive lever (left) (2) Drive lever (right) (A) "Forward" (B) "Backward" (C) "Straight"

URNS

CAUTION

To avoid personal injury:

- Do not change direction on steep slopes, or the excavator could tip over.
- Before changing direction, beware of people in the work area.

■ Pivot Turn

NOTE :

- Movement as illustrated is done with the dozer blade in front of the operator.

◆ Change of Direction while Travelling

1. While travelling forward, bring the left drive lever into the neutral position; the excavator will turn in the direction of the arrow of the illustration below.

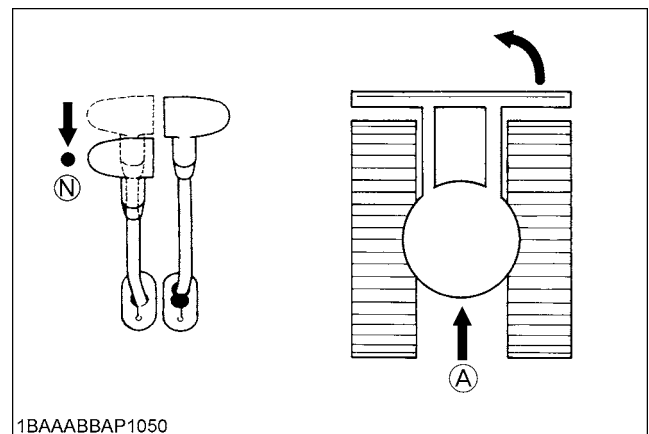

(A) "Travelling forward" (N) "Neutral position"

2. While travelling backward, bring the left drive lever into the neutral position; the excavator will turn in the direction of the arrow of the illustration below.

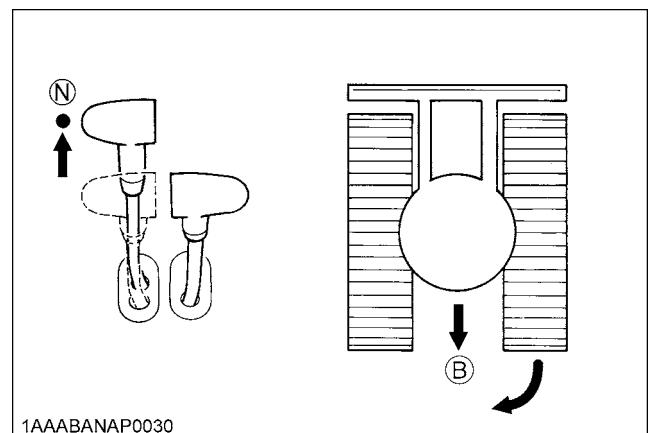

(B) "Travelling backward" (N) "Neutral position"

◆ **Change of Direction while Stationary**

- 1. Push the left drive lever forward; the excavator will turn in the direction of the arrow of the illustration below.

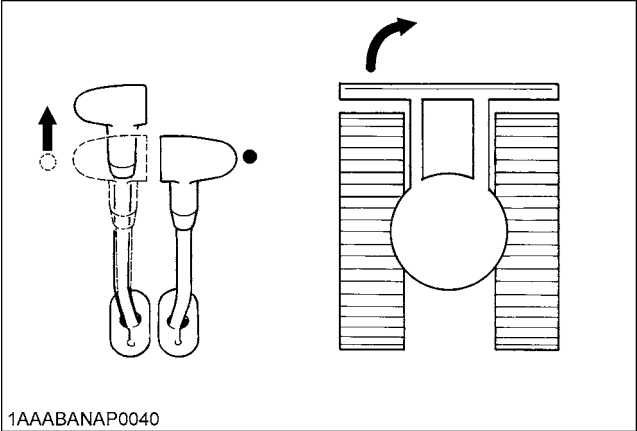

- 2. Pull the left drive lever backward; the excavator will turn in the direction of the arrow of the illustration below.

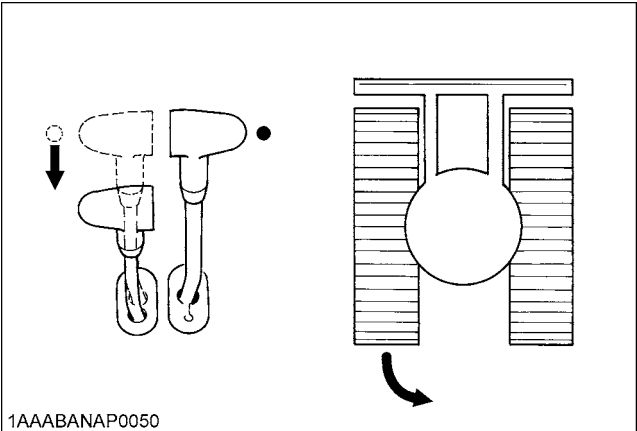

■ **Spin Turn**

When both drive levers are activated in the opposite directions, both tracks will rotate with the same speed but in opposite directions. The center of rotation is the center of the excavator.

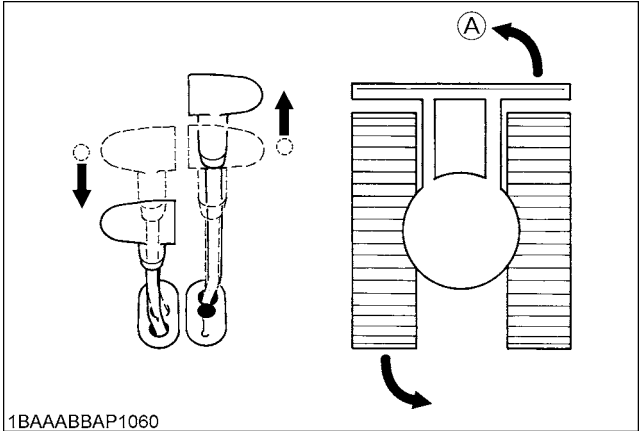

(A) "Left spin turn"

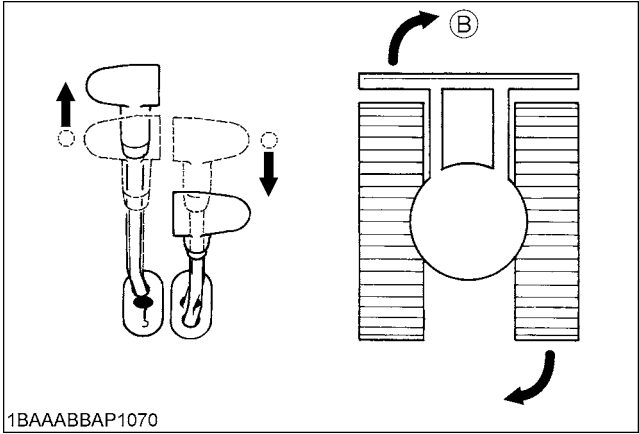

(A) "Right spin turn"

UP AND DOWNHILL DRIVING



CAUTION

To avoid personal injury:

- When travelling up or down a slope, use extra caution and follow the instructions below.

While traveling uphill, keep the lower edge of the bucket approx. 20 to 40cm above the ground. Although the KUBOTA excavator will not slip easily because of the tracks, it is safer to let the bucket slide over the ground while traveling downhill. Always choose slow speed for uphill and downhill traveling.

[UPHILL TRAVELING]

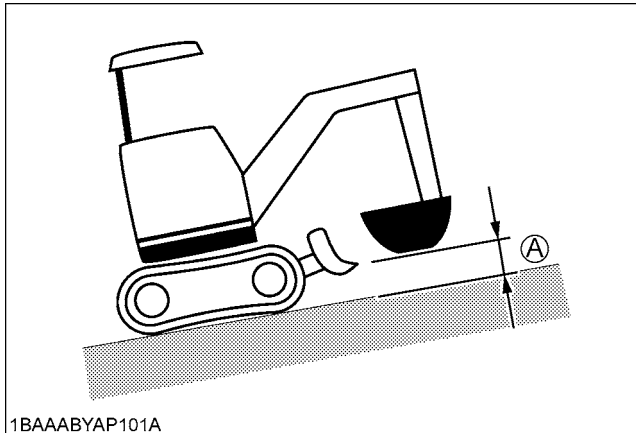

1BAAABYAP101A

(A) 20 to 40 cm

[DOWNHILL TRAVELING]

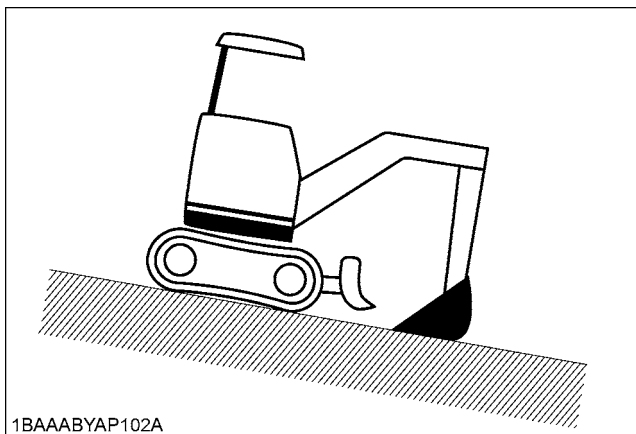

1BAAABYAP102A

PARKING ON A SLOPE



WARNING

To avoid personal injury or death:

- When the excavator is parked or left unattended on a slope, be sure to put the bucket on the ground and place all control levers in neutral position, then brace the tracks with chocks.

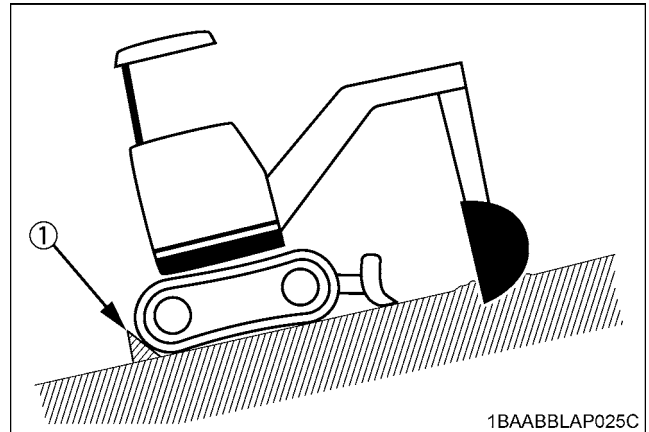

1BAABBLAP025C

(1) Chock

OPERATION OF THE DOZER

1. To raise the dozer, pull back the control lever. To lower the dozer, push the control lever forward.

To float the dozer, push the control lever more forward to the locked position.

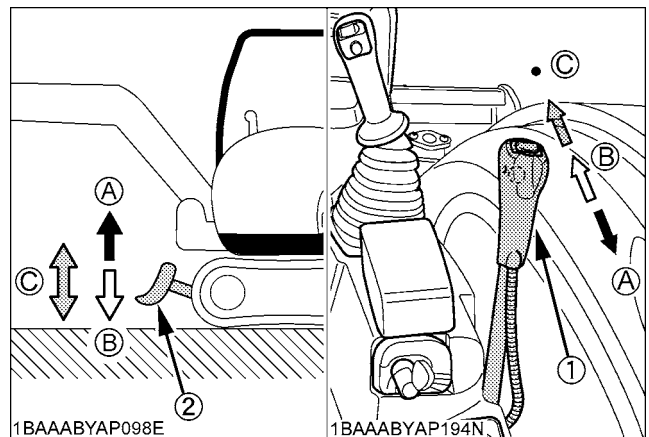

1BAAABYAP098E

1BAAABYAP194N

(1) Dozer control lever

(2) Dozer

(A) "Raise"

(B) "Lower"

(C) "Float" (Locked position)

2. While undertaking earth moving work, control both drive levers with the left hand and the dozer control lever with the right hand.

TWO PATTERN SELECTION SYSTEM(TPSS)



CAUTION

To avoid personal injury:

- Study control lever pattern A and pattern B. Then choose the one which is most familiar.
- Position the pattern selector lever (located on the right side of operator's seat) in either the lower position (Pattern A) or the upper position (Pattern B).
- Engage the lever lock to prevent accidental pattern change.
- Familiarize yourself with the pattern selected by operating slowly.

■ Pattern Change

1. Disengage the lever lock to open the cover and position the pattern selector lever to the desired position.
2. Close the cover and engage the lever lock.

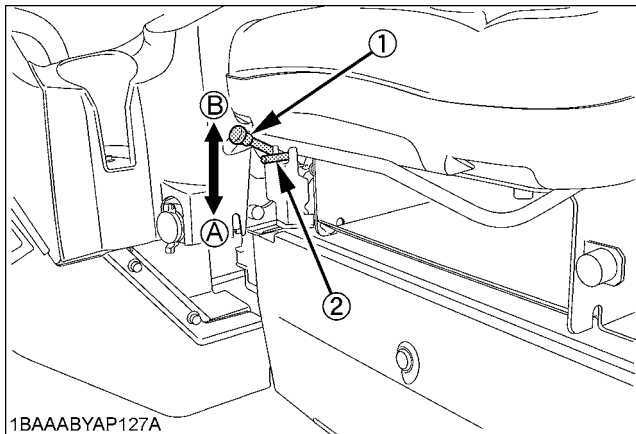

- (1) Pattern selector lever (Two Pattern Selection System:TPSS) (A) "Pattern A"
 (B) "Pattern B"
 (2) Lever lock

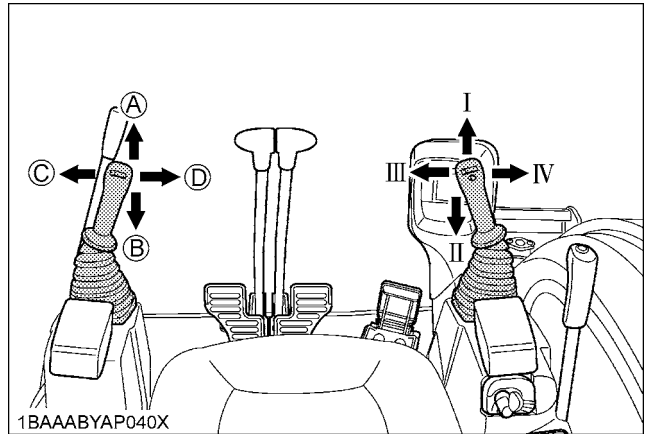

Lever Position		Pattern A	Pattern B
Attachment Control Lever (Left)	A	Boom down	Arm up
	B	Boom up	Arm crowd
	C	Swing left	Swing left
	D	Swing right	Swing right
Attachment Control Lever (Right)	I	Arm up	Boom down
	II	Arm crowd	Boom up
	III	Bucket crowd	Bucket crowd
	IV	Bucket dump	Bucket dump

OPERATION OF THE BOOM

To raise the boom, pull the attachment control lever back. The boom is equipped with a cushion cylinder which helps prevent excavated material in the bucket from falling out. At low hydraulic oil temperature, (e.g. after starting the engine in cold weather) the cushioning function will be effected for a short period of time (approx. 3 to 5 seconds). This condition results from the viscosity of the hydraulic oil and is not a sign of malfunction. The cushion cylinder will operate normally as the oil warms up. To lower the boom, push the attachment control lever forward.

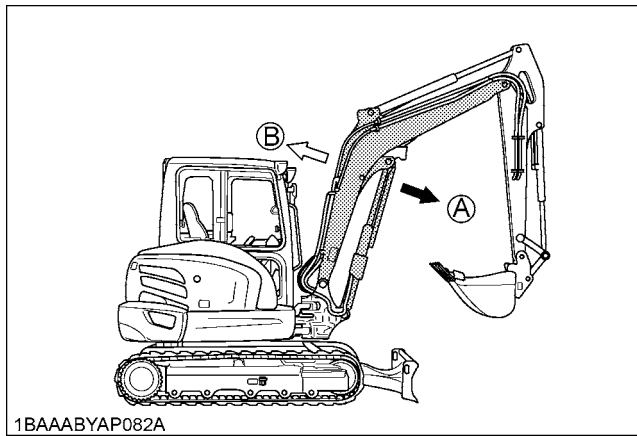
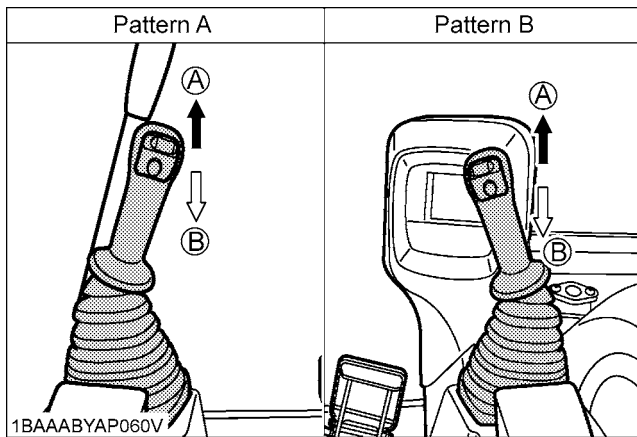

IMPORTANT :

- When lowering the boom, make sure that it does not hit the dozer and that the bucket teeth do not touch the dozer.

OPERATION OF THE ARM

Pull back the attachment control lever and the arm will be pulled in. To move the arm out, push the control lever towards the front.

NOTE :

- When pulling in the arm, the movement may stop for a short moment when the arm is in its vertical position. This is caused by the combined load of the arm and bucket moving the cylinder piston away from the hydraulic flow causing a delay in the cylinder action, until the flow catches up with cylinder piston. This is a characteristic of the hydraulic system and is not a sign of malfunction.

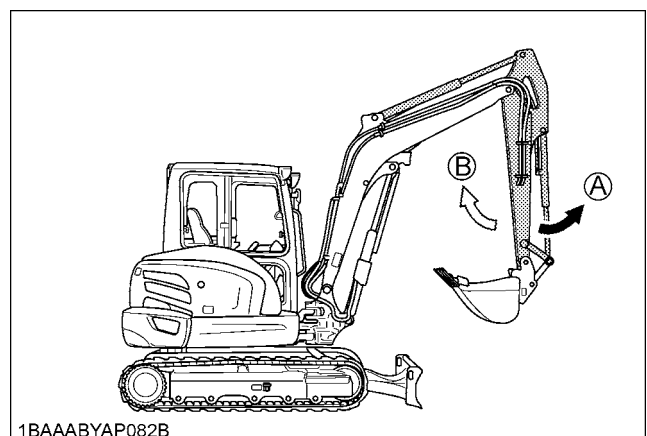
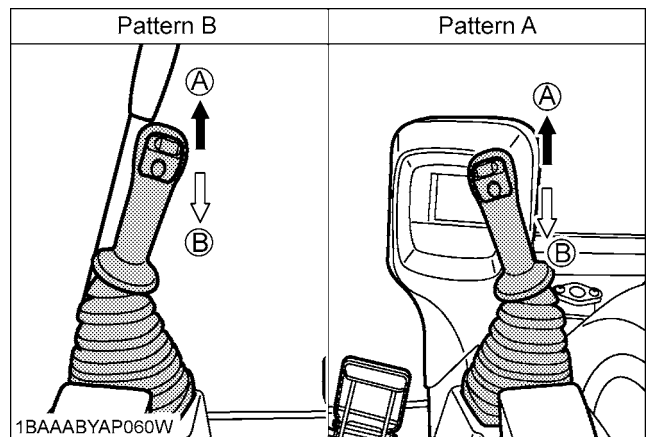

OPERATION OF THE BUCKET

To dig using the bucket, move the right attachment control lever from the neutral position, left. Moving the control lever right, moves the bucket outwards and empties its contents.

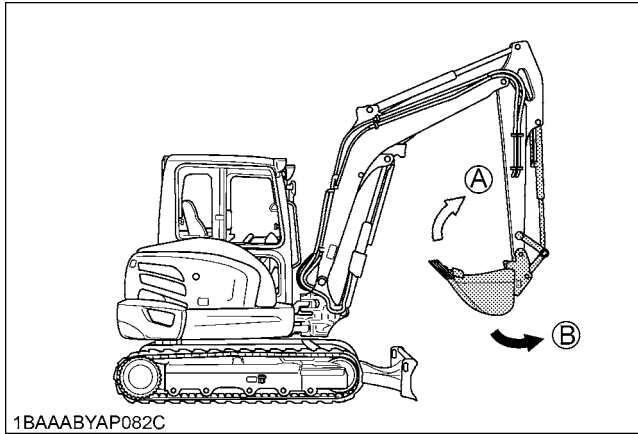
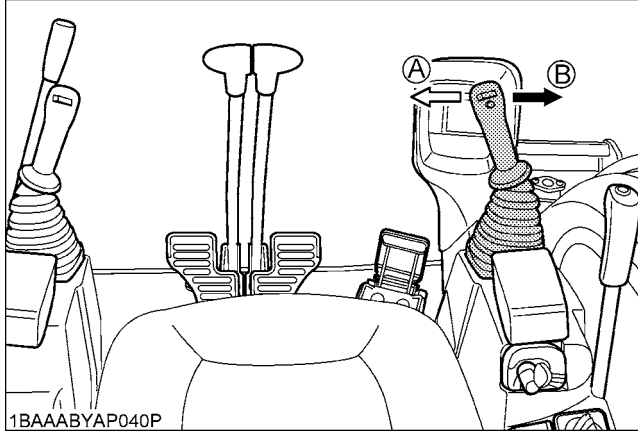

UNIT SWING AND BOOM SWING OPERATION



CAUTION

To avoid personal injury:

- When working in groups, always let the others know what you are going to do before you do it.
- Keep others away from the machine working area.
- Be sure to lock the boom swing pedal when the boom swing function is not used.

Unit Swing Operation

1. Move the control lever to the left and the upper structure will turn to the left.
2. Move the control lever to the right and the upper structure will turn to the right.

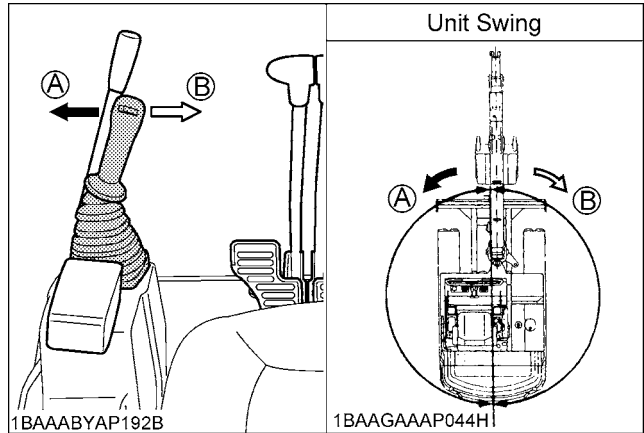

Boom Swing Operation

1. Flip the pedal lock up to unlock the pedal.
2. Step on the left side of the pedal to swing the boom to the left.
3. Step on the right side of the pedal to swing the boom to the right.

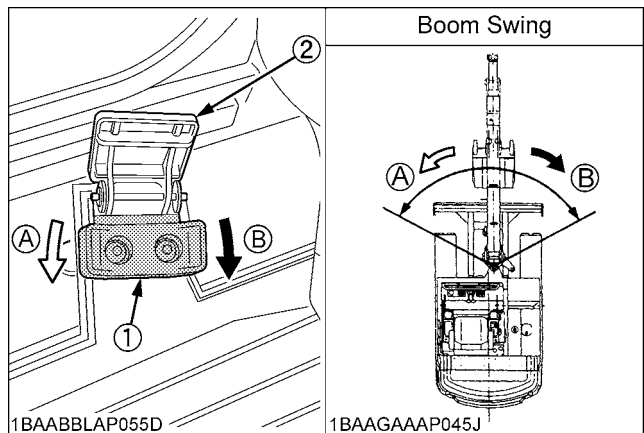

- (1) Boom swing pedal
(2) Pedal lock

IMPORTANT :

- Do not operate the left attachment control lever abruptly from right to left (or vice versa), because the inertia may cause high impact loads on the swing gear and the swing motor, shortening the life of the excavator.

AUXILIARY PORT OPERATION

The auxiliary port enable switch is used to operate hydraulic attachment such as hammers.

■ Selecting the Action Modes

The AUX port has been factory-set to three action modes. You can select one of them. Up to five action modes can be preset.

Each time the AUX port enable switch (switch 3) is pressed, the action modes change over one after another. And the icon and action mode number on the screen change accordingly.

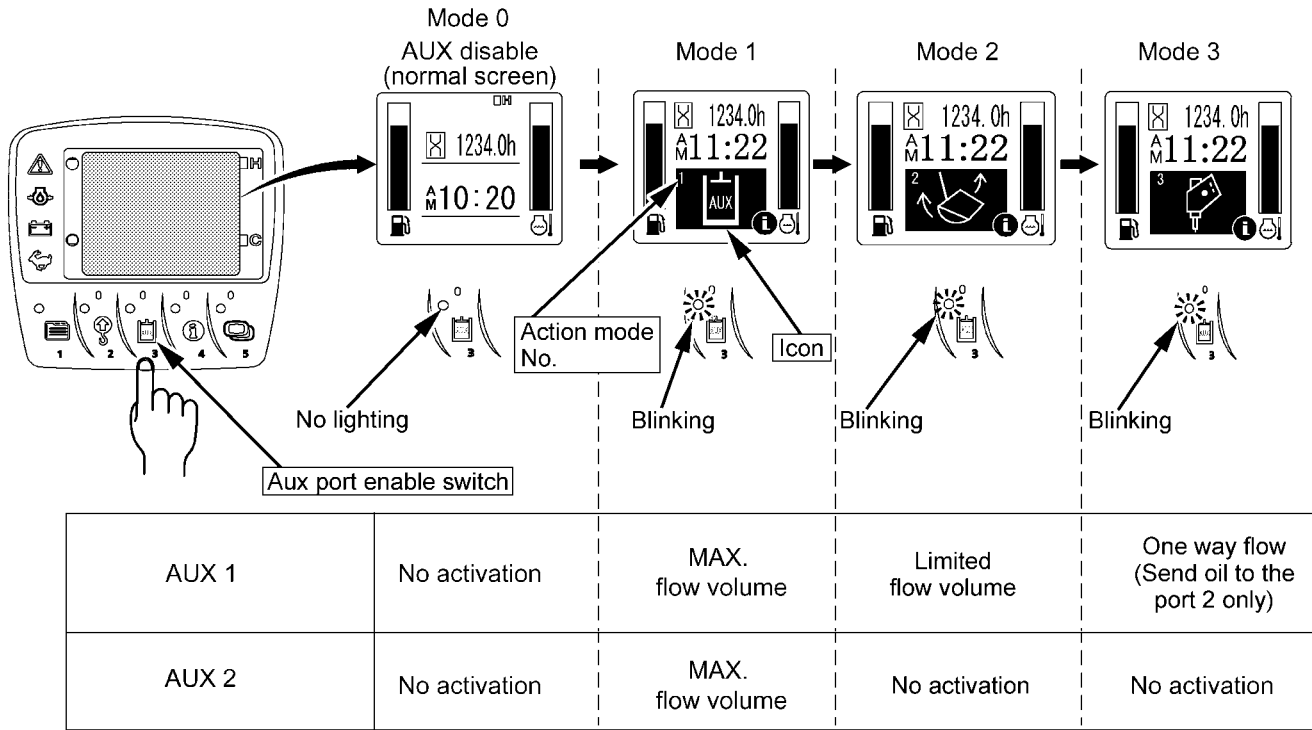

1BAAABYP0080

NOTE :

- When turning the starter key to the "RUN" position, the action mode will return to the last action mode used.

◆ **Checking the settings of each action mode**

When an action mode is selected and the "i" mark appears at the lower right of the icon, the flow volume setting gets displayed by pressing the switch 4.

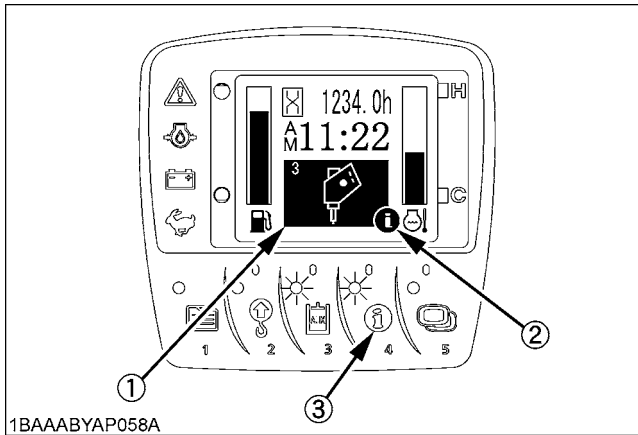

- (1) Icon
- (2) Information mark
- (3) Information switch (Switch 4)

[Display in AUX 1 and 2 modes]

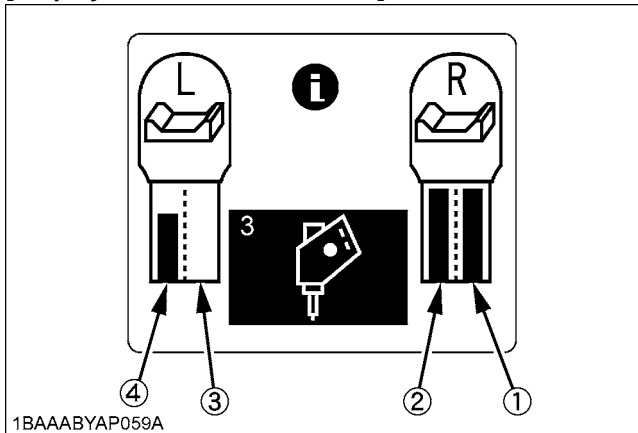

- (1) AUX Port 1
- (2) AUX Port 2
- (3) AUX Port 3
- (4) AUX Port 4

■ **AUX Port Handling Procedure**

1. Turn the starter key to the "RUN" position.
Let the engine warm up after start-up for approx. 10 minutes under no load conditions.

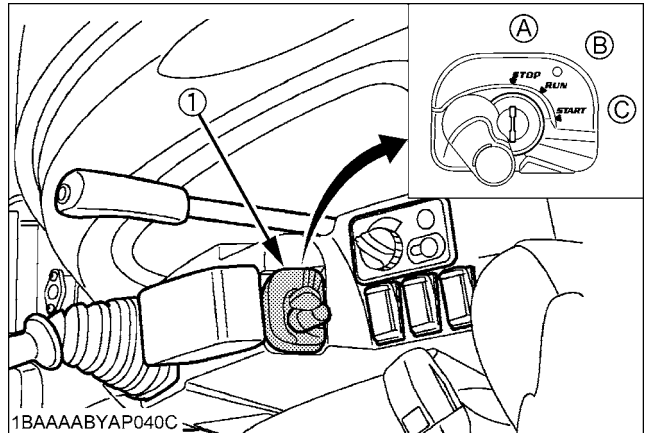

- (1) Starter switch
- (A) "STOP"
- (B) "RUN"
- (C) "START"

2. Lower the pilot control lock lever (UNLOCK).

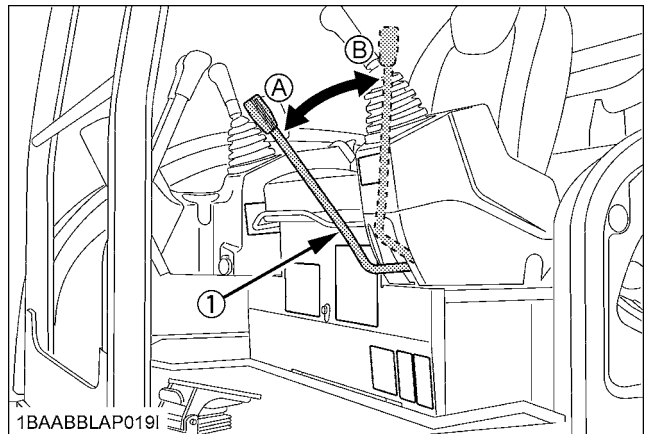

- (1) Pilot control lever
- (A) "Unlock"
- (B) "Locked"

3. Push the AUX port enable switch (switch 3).

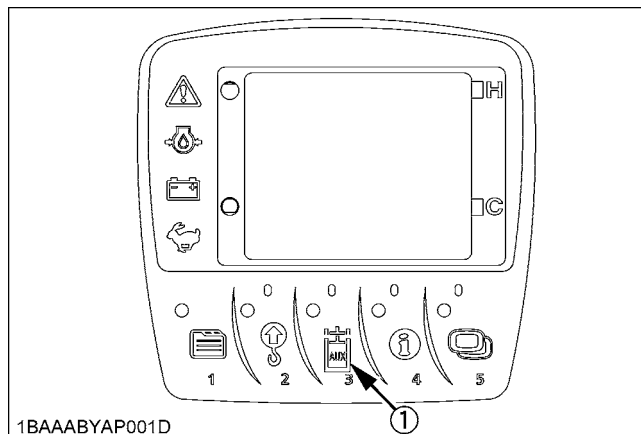

(1) AUX port enable switch (Switch 3)

NOTE :

- If the pilot control lock lever is at the "LOCKED" position, the following message appears onscreen. Down this lever to the "UNLOCKED" position and then press the AUX port enable switch (switch 3).



4. If the machine is equipped with the AUX 1 port, move the AUX port knob of the right attachment control lever to the right to send oil to the AUX port 1. Move the AUX port knob of the right attachment control lever to the left to send oil to the AUX port 2. If the machine is equipped with the AUX 2 port, move the AUX port knob of the left attachment control lever to the right to send oil to the AUX port 3. Move the AUX port knob of the left attachment control lever to the left to send oil to the AUX port 4.

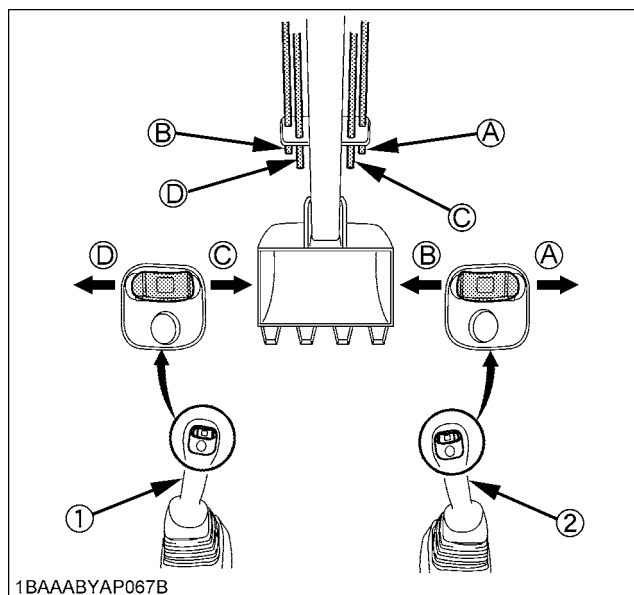

- | | |
|--------------------------------------|------------------|
| (1) Attachment control lever (left) | (A) "AUX port 1" |
| (2) Attachment control lever (right) | (B) "AUX port 2" |
| | (C) "AUX port 3" |
| | (D) "AUX port 4" |

IMPORTANT :

- Proportional control of the AUX port knob allows for slow-to-fast movement of attachment. Example; If you move the AUX port knob halfway, the attachment will move at approximately one-half speed.

◆ **One way hold**

[AUX 1 and 2 modes]

Press the one way hold switch of the right attachment control lever, and the oil continues to flow through the AUX port 4. Press this switch again or move the AUX port knob, and the oil flow is interrupted.

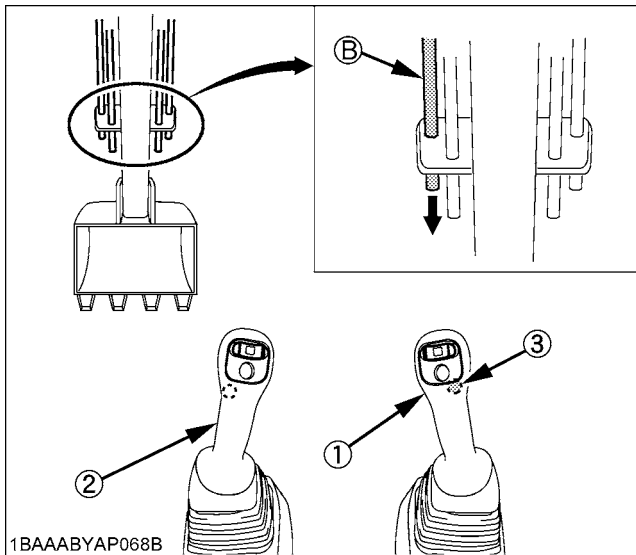

1BAAABYAP068B

- (1) Attachment control lever (right)
- (2) Attachment control lever (left)
- (3) One way hold switch (right)
- (B) "AUX port 2"

NOTE :

- Even if the one way hold switch of the left attachment control lever is pressed, no function is assigned. In this case, the following message appears onscreen.



1BAAABYAP064A

■ **Setting the Maximum Flow Volume**

The AUX port has been factory-set to three action modes 1, 2 and 3. The action modes 4 and 5 can also be preset.

◆ **How to make the settings**

1. With the starter key at the "RUN" position, press the user setting switch (switch 1), and the following display appears onscreen.

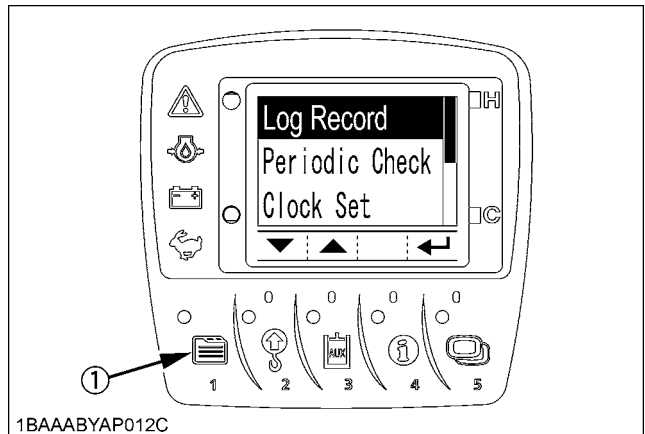

1BAAABYAP012C

- (1) User setting switch (switch 1)

2. Press the switch 2 or 3 to select "AUX Flow Ctrl Set", and then press the switch 5.

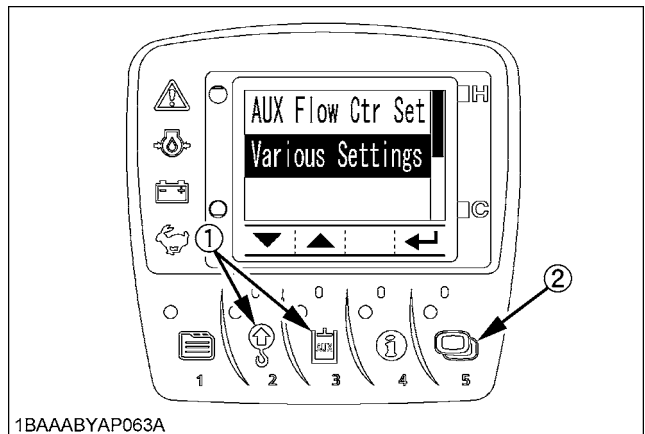

1BAAABYAP063A

- (1) Switch 2 and 3
- (2) Switch 5

3. Each time the switch 5 is pressed, the mode number changes. Select your desired setting mode number.

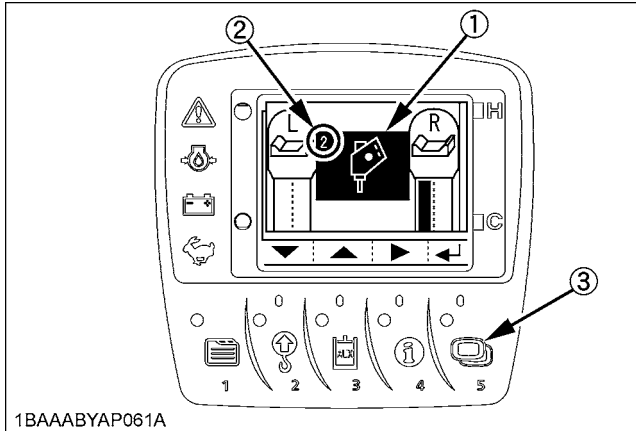

- (1) Icon
- (2) Mode No.
- (3) Switch 5

4. Take the following steps to set the icons.
Each time the switch 4 is pressed, the setting cursor (arrow mark) shifts position. Move the cursor above the icon.

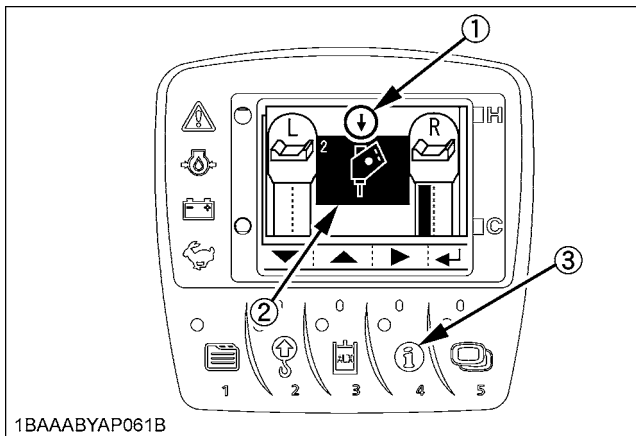

- (1) Setting cursor (arrow mark)
- (2) Icon
- (3) Switch 4

5. Each time the switch 2 or 3 is pressed, the icon changes. Select your desired icons.

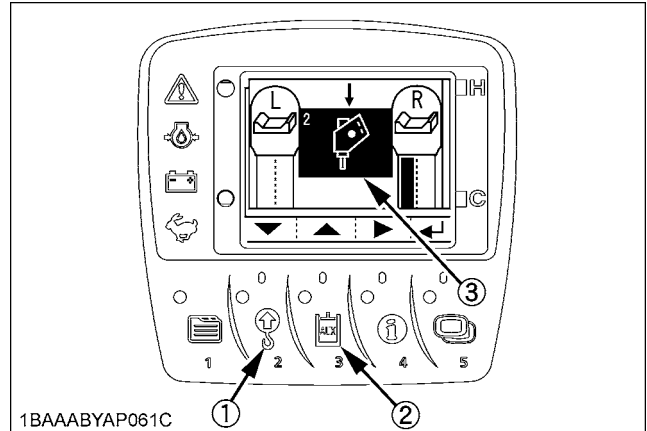

- (1) Switch 2
- (2) Switch 3
- (3) Icon

◆ Types of AUX icons

1		6	
2		7	
3		8	
4		9	
5			

1BAAABYAP062A

- (1) AUX (Standard)
- (2) Brush cutter
- (3) Rotary grapple
- (4) Grapple
- (5) Auger
- (6) Clamshell
- (7) Breaker
- (8) Tilt bucket
- (9) Blank (disable)

NOTE :

- There is no relationship between the icons and the flow control settings. Select icons to suit the images of attachments to be connected.
- In an action mode with the disable icon preset, such action mode is skipped even if selected.

Take an example of the following settings:
 AUX (standard) icon for action mode 1,
 Breaker icon for action mode 2,
 Disable icon for actions modes 3, 4 and 5.

Each time the AUX port enable switch (switch 3) is pressed, the display changes from action mode 1, action mode 2 to normal mode in this order.

[Setting example]

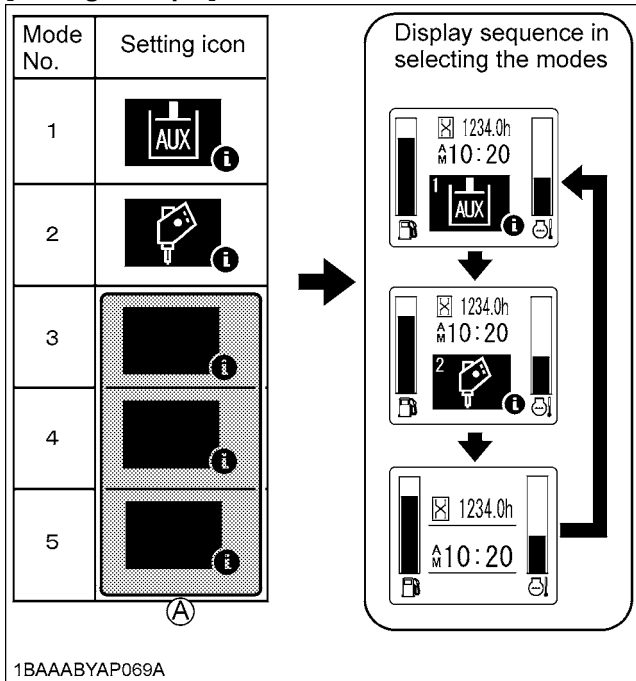

(A) Blank (disable) icon

- Set the maximum flow volume for each AUX port.
 Press the switch 4 to move the setting cursor (arrow mark) to the port 2 position of Thumb port at the right.

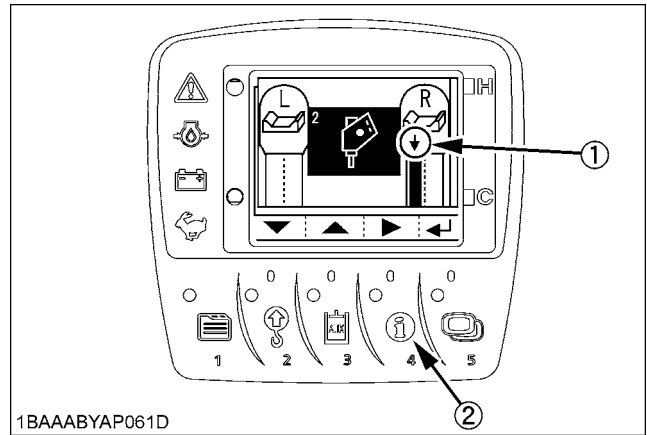

- Setting cursor (arrow)
- Switch 4

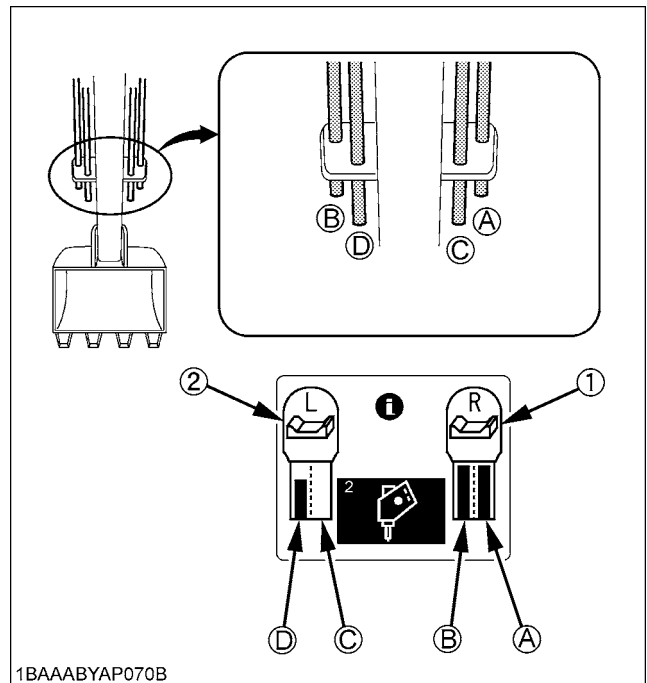

- | | |
|-----------|------------------|
| (1) AUX 1 | (A) "AUX port 1" |
| (2) AUX 2 | (B) "AUX port 2" |
| | (C) "AUX port 3" |
| | (D) "AUX port 4" |

7. Press the switch 2 or 3 to preset the maximum flow volume.

Set the bar to the highest level, and the flow volume will be maximized.

Set the bar to the lowest level (no bar displayed), and there will be no oil flow.

Then press the switch 4 to go to the next port, and make the settings for all the other ports.

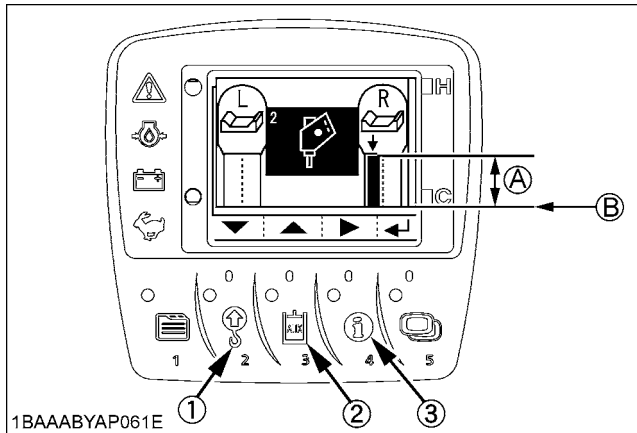

- (1) Switch 2 (Higher flow volume) (A) "MAX. flow volume"
- (2) Switch 3 (Lower flow volume) (B) "Output interrupted"
- (3) Switch 4

NOTE :

- Some attachments might not be activated even when the bar level is still somewhat above the lowest position. Or even when the bars of ports 1 and 2 (or of ports 3 and 4) are at the same level, the same speed might not be achieved. This does not indicate a machine problem, however. Readjust the bar to the optimum level according to your attachment manual.
- Suppose that the same attachment is mounted on another machine. Even if the same flow control setting is made, the same speed cannot be achieved. Make an optimum setting on each machine.

8. Go back to Step 3 to make settings for the next action mode. When all the settings of all the action modes have been made, press the switch 1 to return to the normal screen.

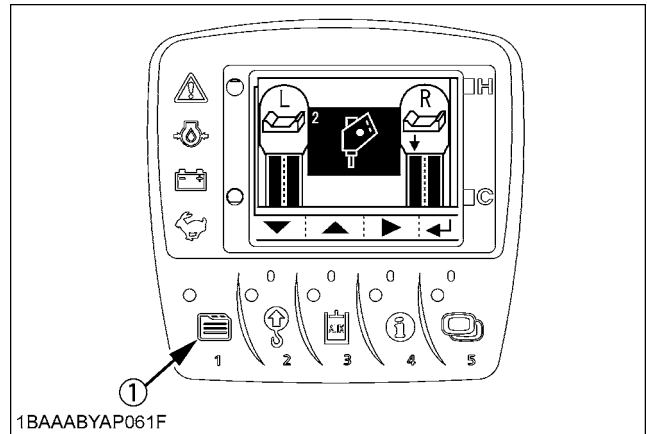

- (1) Switch 1

◆ AUX port MAX. Flow volume

	AUX 1 port	AUX 2 port
MAX. flow volume (Theoretical L/min)	75 (20)	37 (9.87)
MAX. pressure MPa (kgf/cm ²) [psi]	17.2 (175) [2500]	17.2 (175) [2500]

IMPORTANT :

- When the AUX port is not used for a long period, dirt particles can settle in the lower part of the AUX port lines. When the plugs on the AUX port lines are removed to connect attachments, drain approx. 100 cc (3.4 oz) of oil before making connections.

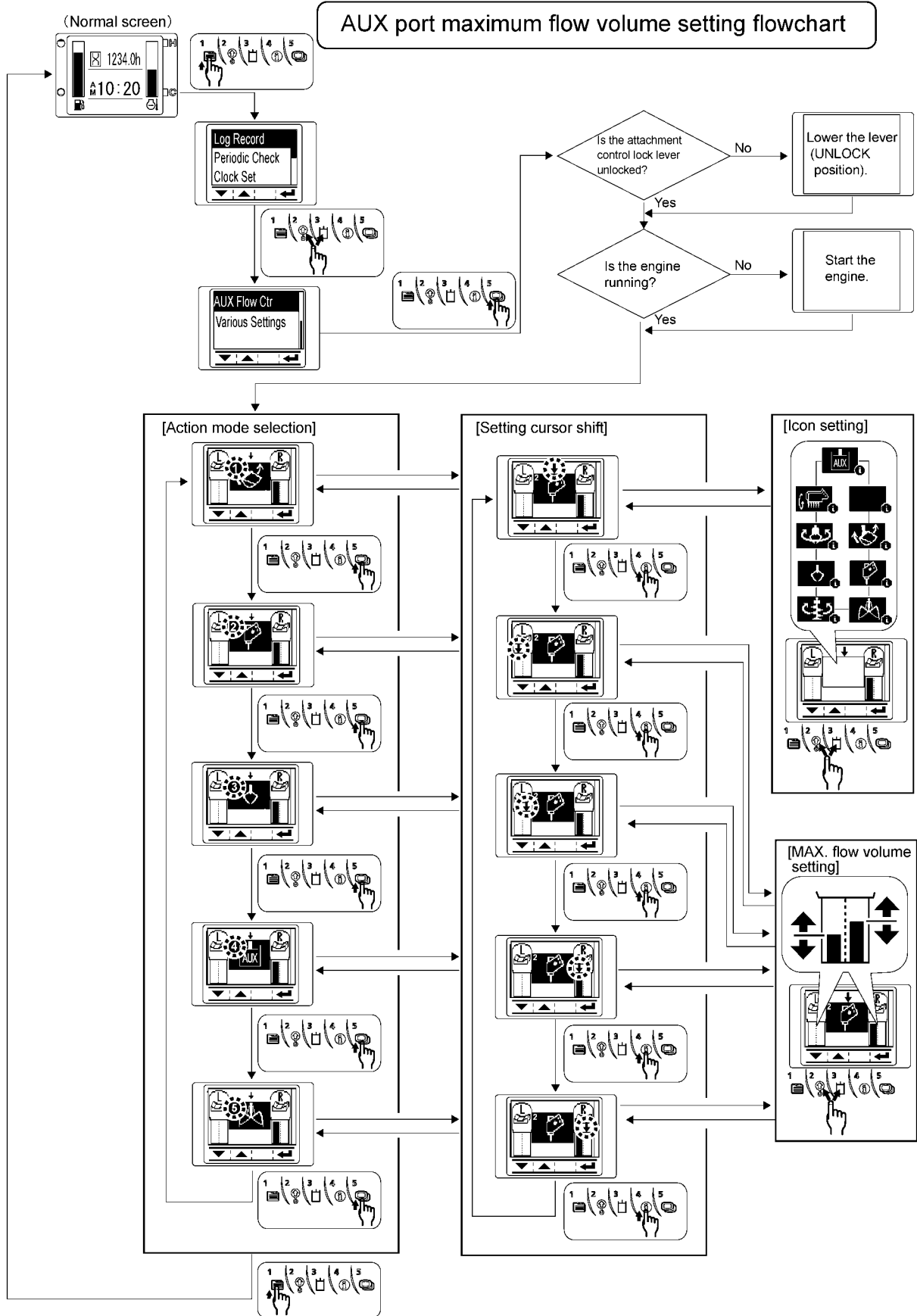

HOW TO RELEASE PRESSURE TRAPPED IN THE HYDRAULIC SYSTEM

1. Lower the attachments and the blade down to the ground.
2. Turn the key to "STOP" position and shut off the engine.
3. After stopping the engine, turn the key to "RUN" position.
4. Set the lock lever to "Unlock" position.

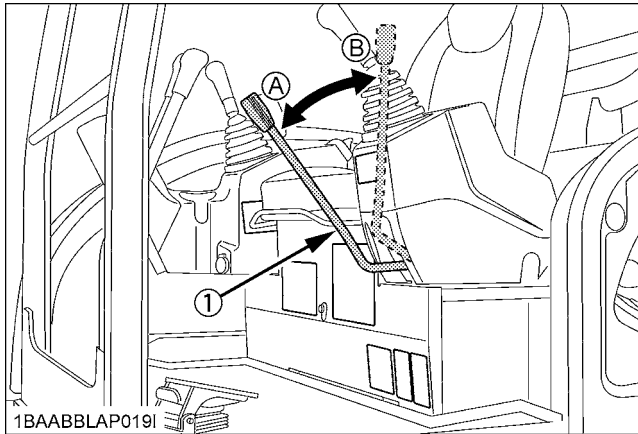

- (1) Lock lever for attachment control (A) "Unlock"
 (2) Attachment control lever (left) (B) "Lock"

5. Move the operating lever to release pressure in the hydraulic system.

[How to release pressure trapped in the AUX port]

1. Perform the above operations of 1 to 4.
2. Turn "ON" the AUX port enable switch.

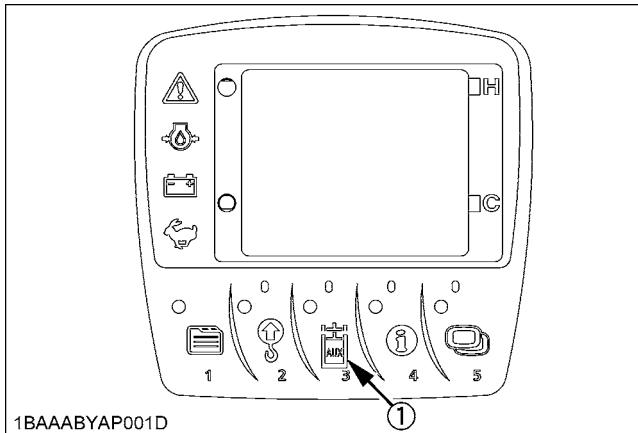

- (1) AUX port enable switch (Switch 3)

3. Make sure that the flow volume in all the AUX ports is not minimized.

If the pressure is removed after minimizing the flow volume in the AUX port, release pressure is not removed completely and the hose coupler may be unable to connect and disconnect.

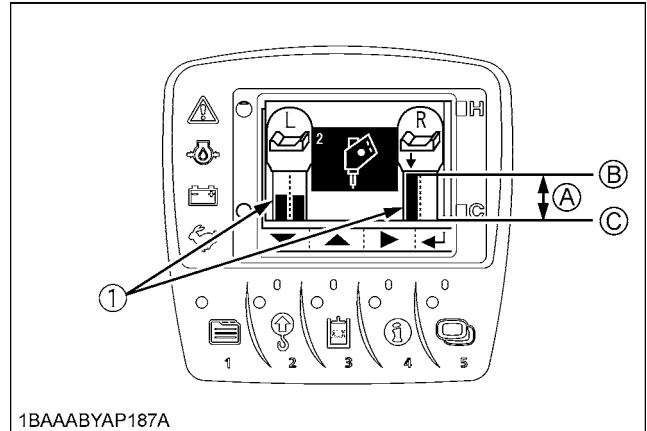

- (1) Flow volume in AUX port display (A) Flow volume in AUX port
 (B) Maximum (C) Minimum

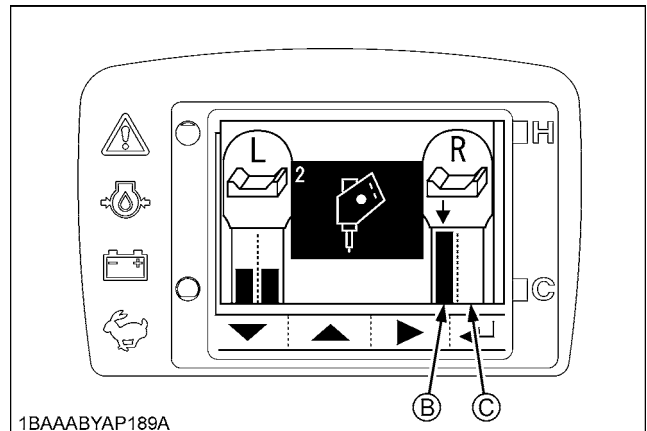

- (B) Maximum status of flow volume in AUX port
 (C) Minimum status of flow volume in AUX port

4. Move the AUX port knob mounted to the operating lever to the right and left to release pressure in the AUX port.

NOTE :

* There are two types of machine, one has the AUX port knobs mounted to the right and left operating levers, the other has the AUX port knob mounted to one operating lever.

Make choice according to the type of machine.

1-way or 2-way CIRCUIT SELECTION VALVE OPERATION

A selection valve which selects 1-way or 2-way circuit of service port has been installed on the hydraulic tank.

1. When equipment which needs a 1-way circuit will be used, position the arrow, by using the selector lever, on the axis of the selection valve to the 1-way circuit position, to reduce the back pressure.
2. When equipment which needs a 2-way circuit will be used, position the arrow on the axis of the selection valve to the 2-way circuit position.

NOTE :

- 1-way circuit..... HAMMER etc.
- 2-way circuit..... THUMB, TILT BUCKET, AUGER, GRAPPLE etc.

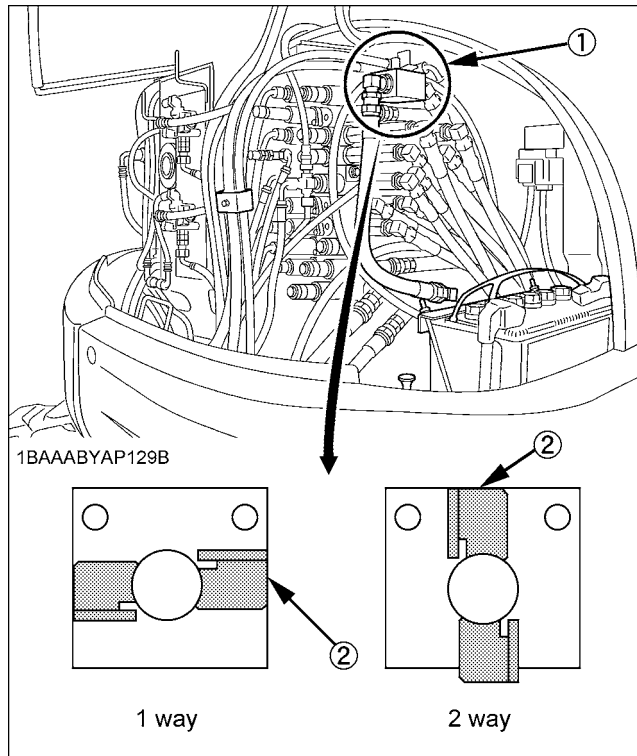

- (1) Selection valve
(2) Selector lever

CAUTION

To avoid personal injury:

- Stop the engine before removing/changing the equipment.
- Release pressure in the hydraulic system before removing/changing the equipment. (See "HOW TO RELEASE PRESSURE TRAPPED IN THE HYDRAULIC SYSTEM".)
- Position the selection valve to the correct position (either 1-way or 2-way circuit selection) before mounting the equipment.
- Always select the correct valve position before mounting the equipment (1-way or 2-way circuit selection) to avoid sudden movement of the equipment.

NOTE :

- Leaving the selection valve to 1-way circuit selection and attaching 2-way circuit equipment may cause the equipment to move (drop) suddenly due to its own weight, as the tank line remains open, even with the engine off.

AUTO IDLE (AI) OPERATION

1. Throttle Potentiometer

With this potentiometer the operator can adjust the engine speed when the Auto Idle control is activated.

2. Switch for Auto Idle (AI) Control

With this switch the Auto Idle control is turned on or off. The Auto Idle control allows the engine speed to drop to idle speed when the control levers are left in neutral for longer than four seconds. If the control is activated, the engine speed rises immediately to the preset rpm. If the Auto Idle is not activated the throttle potentiometer can be utilized to control engine speed in a similar way to a conventional throttle control lever.

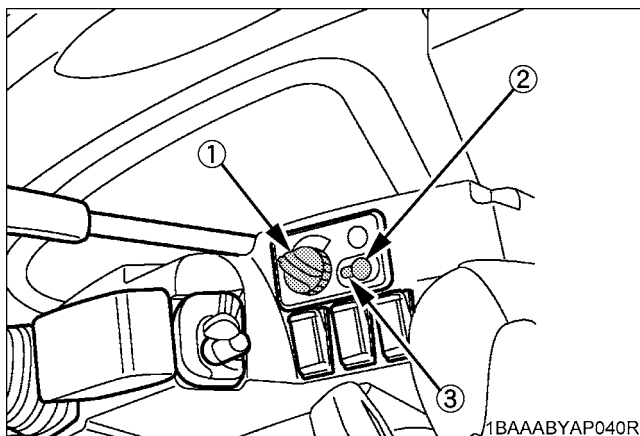

- (1) Throttle potentiometer
 (2) Switch for Auto Idle control
 (3) Lamp for Auto Idle control

IMPORTANT :

- It is possible that the Auto Idle may not function until hydraulic oil warms up in the cold weather. Therefore it is not recommended that the Auto Idle be activated until the machine is completely warmed up.

NOTE :

- Before operating the control lever, check the Auto Idle Indicator Lamp.
- When operating in confined spaces or when loading onto a vehicle, turn the Auto Idle switch off (Light off). This is to prevent unwanted engine speed increases when control levers are activated.
- The Auto Idle control, when selected by a switch, provides the operator with a way to control engine speed without moving the Throttle Potentiometer, simply by not activating any control levers for about four seconds after stopping work, and then to simply restore a preset (by potentiometer) engine speed by activating any control lever to return to work.
- The purpose of the system is to reduce fuel consumption, noise and operator fatigue.
- When the dozer control lever is locked at the "Float" position on the angle blade type, the Auto Idle function is not activated even if any other control lever is set in the neutral position.

IMPORTANT INFORMATION ON EXCAVATOR OPERATION

- Do not try to crush concrete or boulders using side swings with the bucket. Also avoid using side sweeps of the bucket to move earth piles.
- Under all circumstances avoid the following operations:
 - Excavation using the gravitational impact of the machine.
 - Compacting of gravel or soil using the dropping action of the bucket.
 - Excavation using the traveling power of the machine.
- Do not try to drop or shake off soil adhering to the bucket in the manner given in the points below. This can cause damage to the machine. Adhering soil can be shaken off when the bucket is being emptied by moving the bucket out to the maximum stroke of the cylinder. Should this not suffice, swing out the arm as far as possible and operate the bucket back and forth.
- Do not hit the dozer with the boom cylinder! Make sure that the boom cylinder does not hit the dozer when doing deep excavation. If necessary swing around so that the dozer is in the back of the machine.
- Pay attention when pulling in the bucket! When pulling in the bucket (for driving or transportation) avoid hitting the dozer.
- Avoid collisions! When moving the excavator, pay attention that the dozer does not collide with obstructions such as boulders, etc. Such collisions shorten the life of the dozer and the cylinder substantially.
- Support the machine correctly! When stabilizing the machine with the dozer, lower the dozer to engage the full width on the ground.
- If the water or mud level reaches higher than the top of the tracks, the swivel bearing, swivel motor gear and ring gear may be exposed to mud, water and other foreign objects. The excavator must be properly pressure washed after each use.
 - Thoroughly clean the area around the swivel bearing, swivel motor gear and ring gear to remove foreign objects.
 - Inspect the swivel motor oil sump (if equipped) for water contamination. If water is present, refer to operator's manual for lubricant replacement procedure.
 - Refer to operator's manual for proper swivel bearing, swivel motor gear and ring gear lubrication procedures.
 - Reinstall any protective covering if removed earlier.

TRANSPORTING THE EXCAVATOR ON A VEHICLE



DANGER

To avoid serious injury or death:

- No directional changes should be made when the excavator is on the ramp. Should a change of direction be necessary, drive off the ramp completely and make the turn.
- When driving forwards or backwards onto the vehicle, or when swinging the upper body, make sure that neither the CAB or the gates of the vehicle will be damaged.

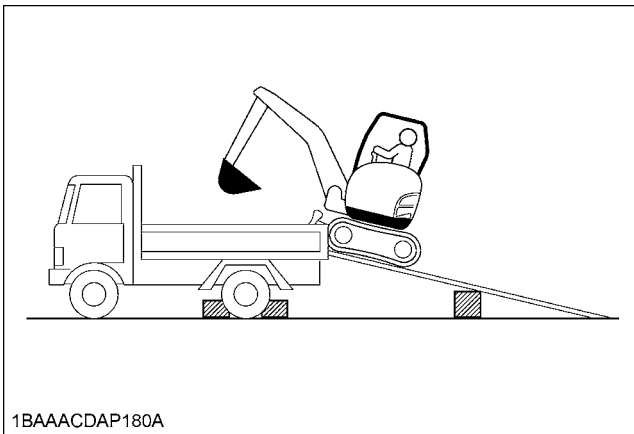

- When the excavator reaches the point between the ramps and the bed, halt and then move very slowly until the excavator reaches the horizontal position.
- Move the excavator onto the vehicle only with the arm completely pulled in.
- Do not jack up the machine using its boom to load or unload the excavator from the vehicle. Doing this is dangerous. Otherwise the CAB of the vehicle could be damaged when swinging around the upper body.
- Make sure the ramps are of sufficient capacity and securely connected to the vehicle to safely support the machine throughout the loading / unloading operation.

■ Transporting on a Truck



WARNING

To avoid personal injury or death:

- After loading the machine on the truck, lower the bucket and dozer onto the truck bed.

Prepare a platform to load or unload the excavator. Take following steps when using ramps.

1. Apply the parking brakes of the vehicle, and block the drive wheels from both sides.

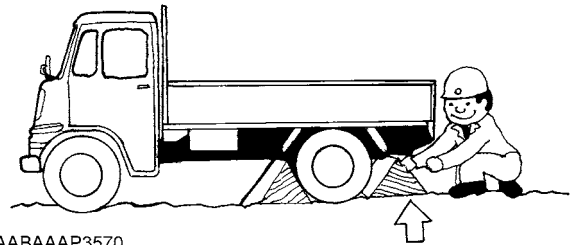

2. Use mounting brackets to secure the ramp properly. Connect the ramps directly with the bed.

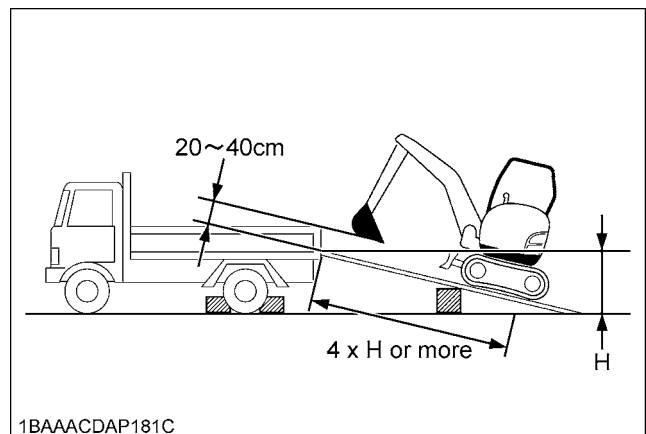

- For additional safety, use blocks or supports under the ramps and the bed.

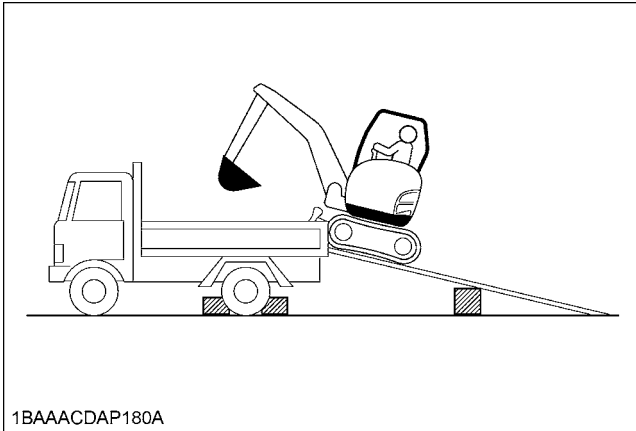

- Completely align the ramps and the tracks and then drive the excavator slowly up the ramps. After ensuring that the tracks are completely on the bed, swing the upper body around to the back of the vehicle.
- Lower the dozer onto the bed.
- Pull in the bucket and arm completely. Then lower the boom.
- Stop the engine, release pressure trapped in the hydraulic system and remove the key.
- Raise the lock lever.
- Block the tracks with blocks and tie down the excavator.

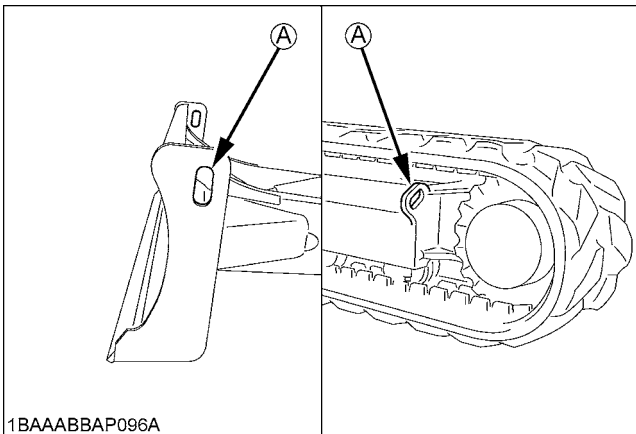

(A) Tie down point

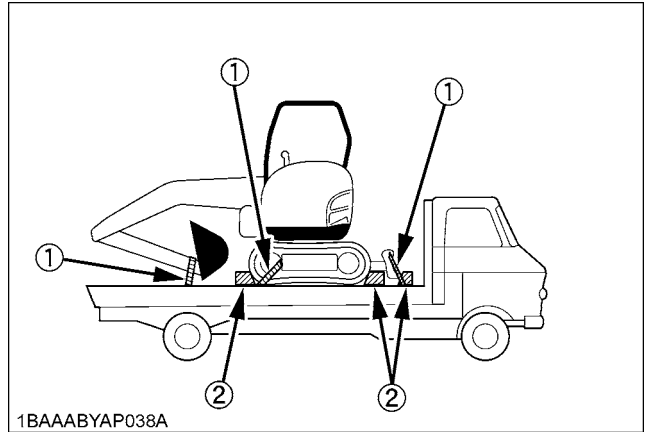

- (1) Chain
- (2) Block

■ Towing the machine



CAUTION

To avoid personal injury:

- When towing the excavator or pulling a load must be less than the strength of the towing line attached to excavator. Not to be used for tiedown or lifting the machine.
- Towing is only allowed over a short distance and at walking speed.

- Attach the tow bar or towing rope to the hook on the excavator and to the pulling vehicle. The tow bar should be mounted at a right angle to the vehicles.
- The operator must be seated during the recovery procedure.
- Drive slowly with the tractive vehicle to avoid abrupt loads.

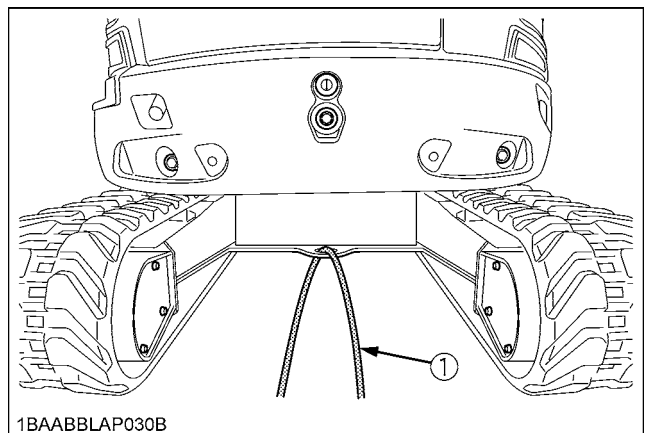

- (1) Tow line

LIFTING OF THE EXCAVATOR



DANGER

To avoid serious injury or death:

- The correct instructions for safe handling are described here. Read these instructions carefully before moving the machine. Make sure that the operating personnel read the operator's manual carefully.

■ Basics when Lifting with Cables or Straps

1. The lifting and crane operation is to be undertaken according to the safe operation guidelines described.
2. The equipment used for lifting mentioned in these instructions are only given as reference, the standards concerning strength, control and other details are based on the respective applicable guidelines.

■ Safety Aspects when Lifting with Cables or Straps

Abide by the following steps when lifting:

1. Do not lift loads that exceed the maximum load capacity of the crane.
2. Choose correct equipment suitable to the weight, size and form of the load.
3. First assess the center of gravity of the load, position the hook directly over the load and lift the load so that the center of gravity of the load is as low as possible.
4. The steel cables or straps must be fixed in the middle of the hook.
5. The load must be lifted vertically from the ground.
6. Do not enter the working area under suspended loads and do not move the load over people. The load must only be moved in an area where the balance can be easily maintained.

■ Lifting Procedure for the Excavator



WARNING

To avoid personal injury or death:

- Do not use the hooks on the roof of canopy and CAB for lifting the excavator.
- When applying the shackles through the boom's and blade's openings for lifting, be sure to do two-point lifting for added safety.
- Never lift the machine with the angle blade placed at an angle. (Angle blade type)

◆ General guidelines for lifting

1. Lifting position. (see illustration below)
 - (1) Rotate the upper swivel structure until the blade positions itself 180-degree opposite the attachment.
 - (2) Raise the blade all the way.

- (3) Lift the boom and get the bucket and arm in their crowded position. Next set the pilot control lock lever to the "LOCKED" position.
- (4) With the boom not swinging, set the swing pedal to the neutral position, place the pedal cover and stop the engine.
- (5) Apply shackles (3200 kg or heavier-duty) through the openings at both ends of the blade. And apply shackles (2000 kg or heavier-duty) through the two openings at the boom top. Pass wire ropes through these shackles.

[Blade ends]

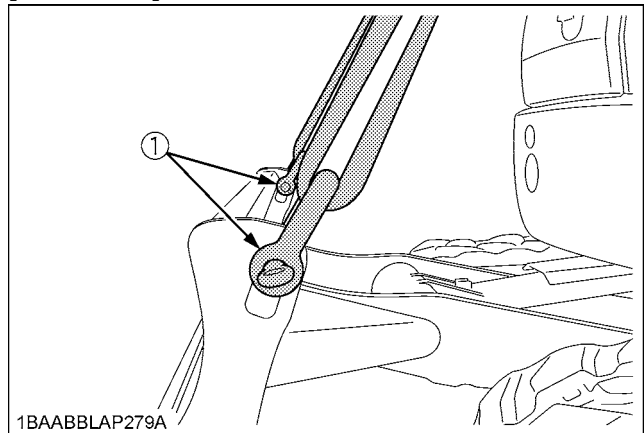

(1) Shackle

[Boom top]

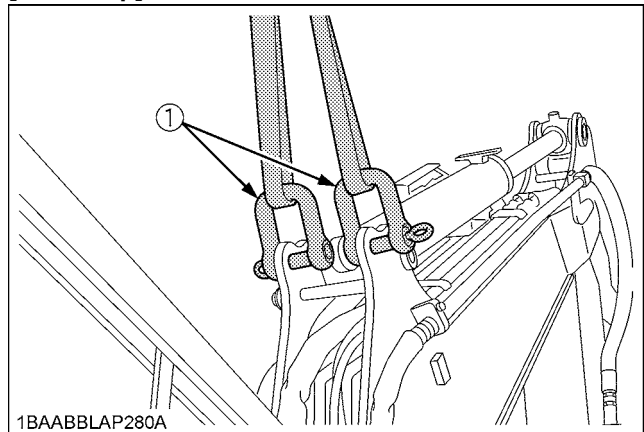

(1) Shackle

2. Attaching the steel cables or straps.
 - (1) Always hook the excavator at three points. (one on the boom and left and right of the dozer)
 - (2) Always use a shackle on each lifting hole when attaching the cables or straps.
 - (3) Keep the angle between the front and rear cables or straps within 51°.

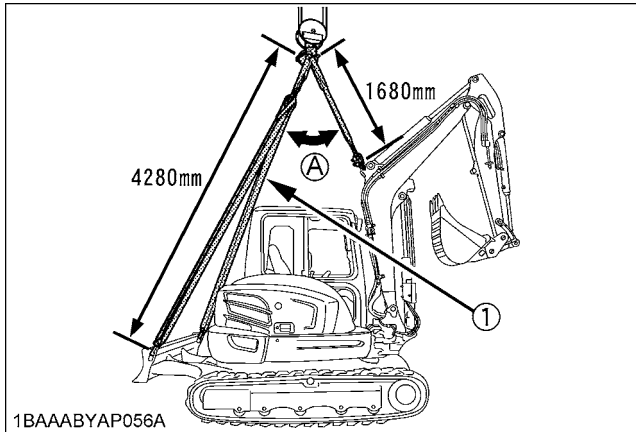

(1) Cable or strap (A) 51° or less

NOTE :

- While lifting, carefully keep the machine well balanced with its center of gravity in mind.
- Do not lift the machine with the boom swinging or the upper structure swiveling.

3. Tackle

The weights of the excavators and the recommended tackle for lifting these loads are mentioned in the following table. Choose components having enough strength.

[KX057-4]

Excavator Weight*	CAB	CANOPY
	5600 kg	5510 kg
Load / Cable	1550 kN (158056 kgf)	
Minimum Wire Diameter (Safety factor=6)	16 mm or more	

[U55-4]

Excavator Weight*	CAB	CANOPY
	5470 kg	5380 kg
Load / Cable	1550 kN (158056 kgf)	
Minimum Wire Diameter (Safety factor=6)	16 mm or more	

*Excavator Weight: With CAB, steel tracks.
Steel wire: 6X24

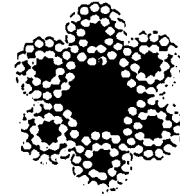

1AAABANAP034A

4. Lifting

- (1) Lift slowly and safely
- (2) Do not enter the excavator area when lifting.
- (3) Lift the excavator horizontally. (Modify cable or strap connections according to needs)

Maximum strength

for example: (JIS G3525: 2006 or ISO 4344: 2004) - "6X24"

Diameter	zinc-plated	not zinc-plated
14 mm (9/16)	89.7 kN (9146 kgf)	96.6 kN (9850 kgf)
16 mm (5/8)	117 kN (11930 kgf)	126 kN (12848 kgf)
18 mm (45/64)	148 kN (15091 kgf)	160 kN (16315 kgf)
20 mm (3/4)	183 kN (18660 kgf)	197 kN (20088 kgf)
22.4 mm (-)	230 kN (23453 kgf)	247 kN (25187 kgf)

MAINTENANCE

MAINTENANCE INTERVALS

No.	Check points		Measures	Hour meter indicator											Interval	Ref. page		
				50	100	150	200	250	300	350	400	450						
1	Coolant		check	Daily check												58		
			change													every 2 years	77	
2	Fuel		check	Daily check												59		
3	Engine oil		check	Daily check												59		
			change	●				○								every 250 hrs	71	
4	Hydraulic oil		check	Daily check												60		
			change													every 1000 hrs	74	*1
5	Grease front attachments	Bucket and bucket link pin	-	Daily check												63		
		Boom swing fulcrum	-	Daily check												62		
		Others	-	Daily check												63		
6	Radiator and oil cooler		check	Daily check												61		
7	Washer liquid		check	Daily check												62		
8	Engine and electrical wiring		check	Daily check												62		
9	Pre-cleaner		clean	Daily check												62		
10	Fuel tank, Water separator		drain	○	○	○	○	○	○	○	○	○	○	○	every 50 hrs	64,64		
11	Battery condition		check	○	○	○	○	○	○	○	○	○	○	every 50 hrs	65			
12	Greasing swing bearing teeth		-	○	○	○	○	○	○	○	○	○	○	every 50 hrs	66			
13	V-belt tension		check	Daily check												60		
			adjust				○						○		every 200 hrs	67		
14	Radiator hoses and clamps		check				○						○	every 200 hrs	68			
			replace												every 2 years	77		
15	Air filter element	Outer element	clean				○						○	every 200 hrs	68	*2	@	
			replace												every 1000 hrs	76		*2
		Inner element	replace												every 1000 hrs	76		*2
16	Greasing swing ball bearing		-				○						○	every 200 hrs	69			
17	Fuel filter cartridge		replace											every 500 hrs	73		@	
18	Engine oil filter		replace					○						every 250 hrs	72			
19	Drive unit oil		change	●										every 500 hrs	72			
20	Breather filter		replace											every 500 hrs	73			
21	Hydraulic return filter element		replace											every 1000 hrs	74			
22	Hydraulic suction filter element		replace											every 1000 hrs	74			
23	Filter in the pilot hydraulic system		replace											every 1000 hrs	73			
24	Fuel injection nozzle injection pressure		check											every 1500 hrs	76	*4	@	
25	Front idler and track roller oil		change											every 2000 hrs	76			
26	Alternator and starter motor		check											every 2000 hrs	76			
27	Injection pump		check											every 3000 hrs	76	*4	@	
28	Radiator system		rinse											every 2 years	77			
29	Fuel line and Intake air line		check				○						○	every 200 hrs	70		@	
			replace												every 2 years	79	*3	

* 500 thru 1000 continued to the following table.

No.	Check points		Measures	Hour meter indicator						Interval	Ref. page				
				500	550	600	650	700	750					800	1000
1	Coolant		check	Daily check							58				
			change								every 2 years	77			
2	Fuel		check	Daily check							59				
3	Engine oil		check	Daily check							59				
			change	○					○		○	every 250 hrs	71		
4	Hydraulic oil		check	Daily check							60				
			change								○	every 1000 hrs	74	*1	
5	Grease front attachments	Bucket and bucket link pin	-	Daily check							63				
		Boom swing fulcrum	-	Daily check							62				
		Others	-	Daily check							63				
6	Radiator and oil cooler		check	Daily check							61				
7	Washer liquid		check	Daily check							62				
8	Engine and electrical wiring		check	Daily check							62				
9	Pre-cleaner		clean	Daily check							62				
10	Fuel tank, Water separator		drain	○	○	○	○	○	○	○	○	every 50 hrs	64,64		
11	Battery condition		check	○	○	○	○	○	○	○	○	every 50 hrs	65		
12	Greasing swing bearing teeth		-	○	○	○	○	○	○	○	○	every 50 hrs	66		
13	V-belt tension		check	Daily check							60				
			adjust			○				○	○	every 200 hrs	67		
14	Radiator hoses and clamps		check			○				○	○	every 200 hrs	68		
			replace										every 2 years	77	
15	Air filter element	Outer element	clean			○				○	○	every 200 hrs	68	*2	@
			replace								○	every 1000 hrs	76	*2	
		Inner element	replace								○	every 1000 hrs	76	*2	
16	Greasing swing ball bearing		-			○				○	○	every 200 hrs	69		
17	Fuel filter cartridge		replace	○							○	every 500 hrs	73		@
18	Engine oil filter		replace	○					○		○	every 250 hrs	72		
19	Drive unit oil		change	○							○	every 500 hrs	72		
20	Breather filter		replace	○							○	every 500 hrs	73		
21	Hydraulic return filter element		replace								○	every 1000 hrs	73		
22	Hydraulic suction filter element		replace								○	every 1000 hrs	74		
23	Filter in the pilot hydraulic system		replace								○	every 1000 hrs	73		
24	Fuel injection nozzle injection pressure		check									every 1500 hrs	76	*4	@
25	Front idler and track roller oil		change									every 2000 hrs	76		
26	Alternator and starter motor		check									every 2000 hrs	76		
27	Injection pump		check									every 3000 hrs	76	*4	@
28	Radiator system		rinse									every 2 years	77		
29	Fuel line and Intake air line		check			○				○	○	every 200 hrs	70		@
			replace									every 2 years	79	*3	

◆ Air-conditioner

No.	Check points	Measures	Hour meter indicator									Interval	Ref. page			
			50	100	150	200	250	300	350	400	450					
1	Air filter	clean				○					○		every 200 hrs	70	*2	
		replace											every 1000 hrs	-	*2	
2	Air conditioner condenser	clean				○					○		every 200 hrs	71		
3	Air conditioner pipes and hoses	check											every 1 year	76		
		replace											every 2 years	77		
4	Refrigerant (gas)	check											service as required	79		

No.	Check points	Measures	Hour meter indicator								Interval	Ref. page				
			500	550	600	650	700	750	800	1000						
1	Air filter	clean			○						○	○	every 200 hrs	70	*2	
		replace										○	every 1000 hrs	-	*2	
2	Air conditioner condenser	clean			○						○	○	every 200 hrs	71		
3	Air conditioner pipes and hoses	check											every 1 year	76		
		replace											every 2 years	77		
4	Refrigerant (gas)	check											service as required	79		

IMPORTANT :

● First operation

*1 When using a hydraulic hammer, change hydraulic oil and return filter according to the table on "Hydraulic Oil Change (Including Exchange of the Suction Filter in the Hydraulic Tank) under "EVERY 1000 SERVICE HOURS" in the chapter "REGULAR CHECKS AND MAINTENANCE WORK".

*2 Clean and replace the air filter more frequently if used under dusty conditions. When the filter is very dirty from dusty conditions, replace the filter.

*3 Replace only if necessary.

*4 Consult your local KUBOTA dealer for this service.

● The items listed above (@ marked) are registered as emission related critical parts by KUBOTA in the U.S.EPA non-road emission regulation. As the engine owner, you are responsible for the performance of the required maintenance on the engine according to the above instruction. Please see the warranty Statement in detail.

OPENING AND CLOSING OF COVERS

■ Opening/Closing of the Engine Hood



CAUTION

To avoid personal injury:

- Do not open the engine hood with the engine running unless in an emergency.
- Do not touch the exhaust muffler or the exhaust pipe; serious burns can occur.

Insert the key into the key slot and turn it clockwise to unlock it. And pull the catch to open the hood.

To close the hood, push down it until it locks automatically.

Turn the key counterclockwise to lock the hood.

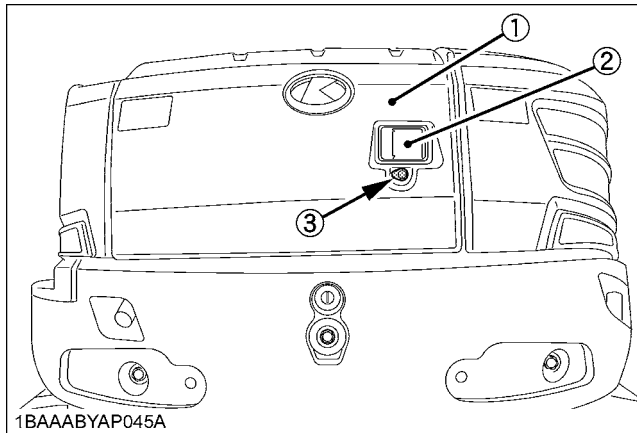

- (1) Engine hood
- (2) Catch
- (3) Key hole

■ Opening/Closing of the Side Cover

1. Insert the starter key in its hole and turn it clockwise to unlock the side cover. Pull the catch, and hold up the side cover until the gas spring fixture stay gets locked.
2. To close the side cover, hold it up a little more, and pull the gas spring fixture stay to get it unlocked. Lower the side cover until it clicks into its closed position.
3. Turn the starter key counterclockwise to get the side cover locked.

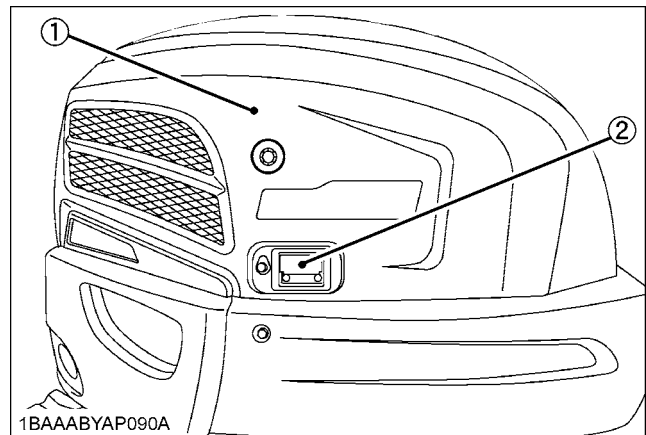

- (1) Side cover
- (2) Catch

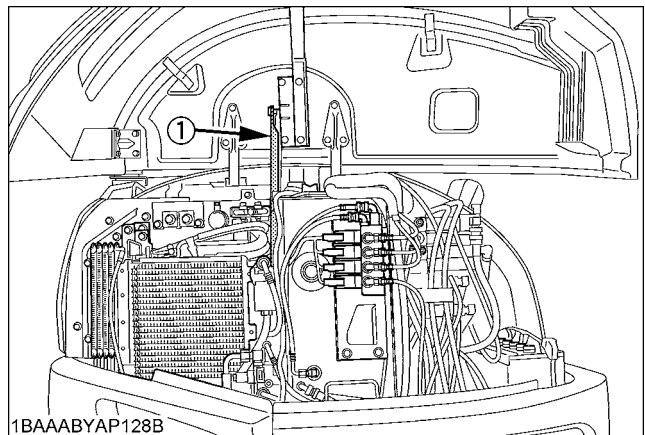

- (1) Stay

Where to store the Tool

1. The tool box is located in front of the right side bonnet.

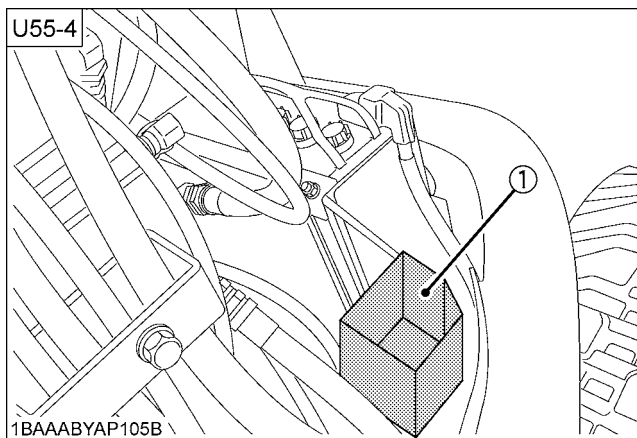
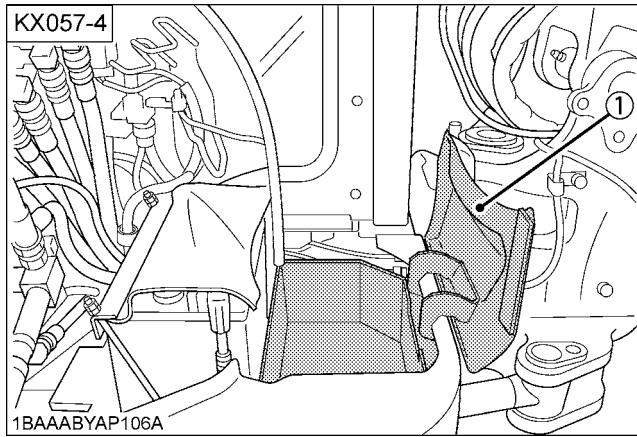

- (1) Box for storage

Where to store the Grease Gun

1. Open the side cover, and the grease gun storage spot will be found inside.

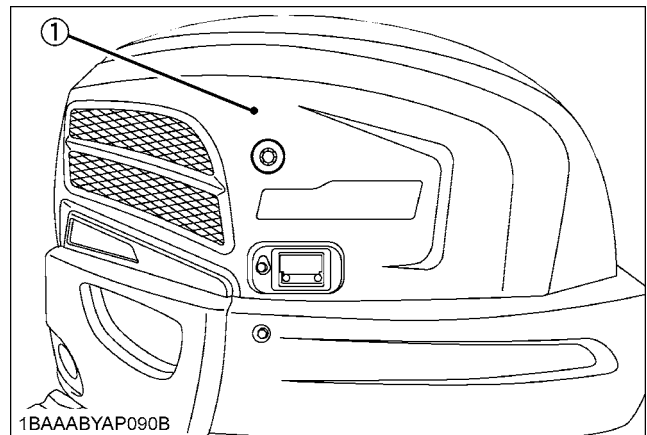

- (1) Side cover

2. After using the grease gun, secure it back to its fixture and close the side cover.
If grease is collected in the grease receiver, wipe it clean with waste cloth or the like.

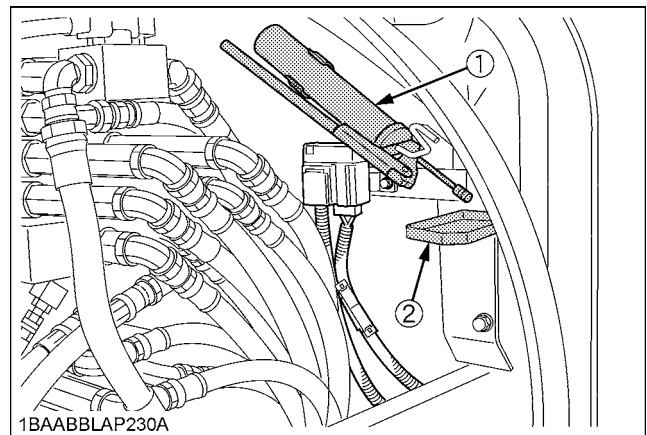

- (1) Grease gun
- (2) Grease receiver

Take note storage direction of greased gun in above illustration.

■ Where to keep Operator's Manual

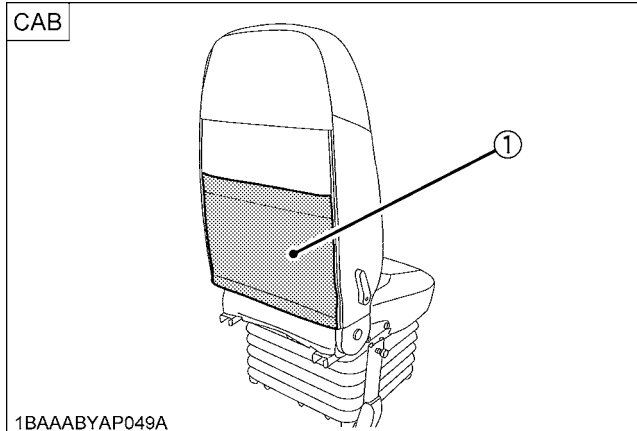

(1) Operator's manual storage

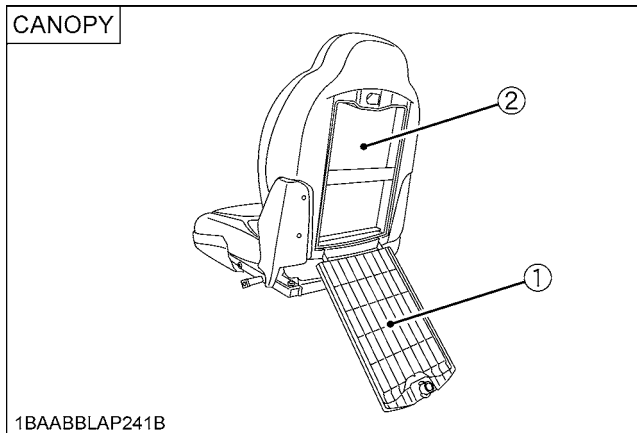

(1) Rear cover
(2) Operator's manual storage

■ Cup Holder

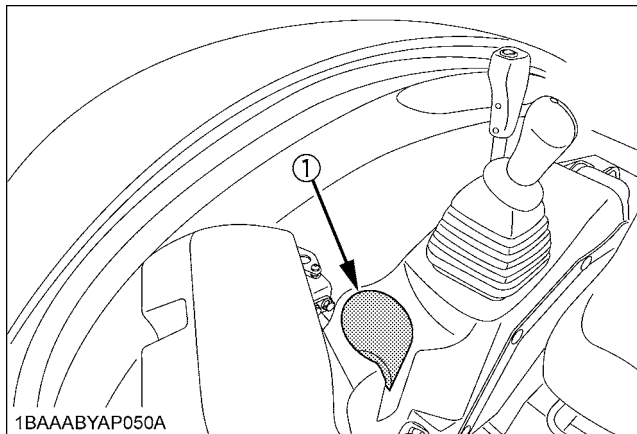

(1) Cup holder

DAILY CHECKS

CAUTION

To avoid personal injury:

- When operating, keep hands and body inside of the ROPS / FOPS protective envelope.
- Do not touch the control levers and the pedals from outside the cab during the engine running.

For your own safety and to assure the long life of your machine, a careful check should be made before each operation.

■ Checking Coolant Level

CAUTION

To avoid personal injury:

- Move the excavator to even ground.
- Make sure that the engine is turned off.
- Do not open the radiator cap right after the engine has been stopped; Serious burns can occur from contact with escaping hot coolant fluid.
- Check the coolant level in the recovery tank only after the engine has cooled down.
- Remove the radiator cap only if absolutely necessary.

The radiator has a recovery tank. Should the coolant level in the radiator sink, the water will be automatically be forwarded to the radiator.

Open the side cover. (See "Opening / Closing of the Side Cover" in "OPENING AND CLOSING OF PARTS" section.)

Check the coolant level in the recovery tank and fill up if necessary. The coolant level should be between the marks "FULL" and "LOW".

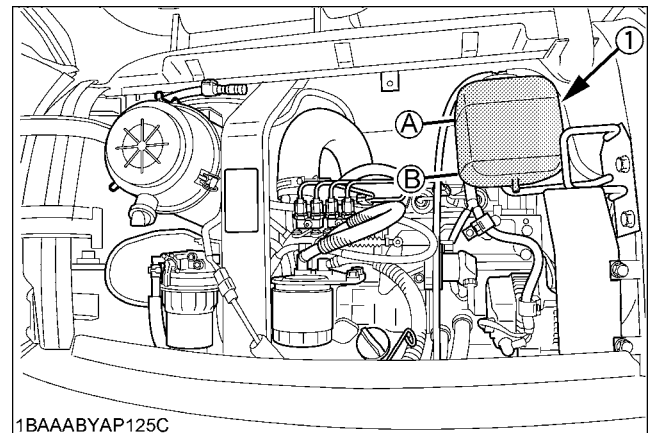

(1) Recovery tank

(A) "FULL"
(B) "LOW"

IMPORTANT :

- Do not fill the recovery tank over the "FULL" marking.
- Do not fill with dirty or salty water.

■Checking Fuel Level



CAUTION

To avoid personal injury:

- Stop the engine and remove the key before fuelling.
- Do not smoke while fuelling.

IMPORTANT :

- By temperatures over -5°C, use No.2-D diesel fuel, when temperatures are under -5°C, use No.1-D diesel fuel.
- Make sure that the fuel tank is not run empty. Air will enter the fuel system, and must be purged before restarting.
- See "PURGING OF THE FUEL SYSTEM" in "OTHER ADJUSTMENTS AND REPLACEMENTS"
- To prevent condensation (water) accumulations in the fuel tank, fill the fuel into the tank before parking overnight.

1. Check the fuel level by the fuel level indicator.

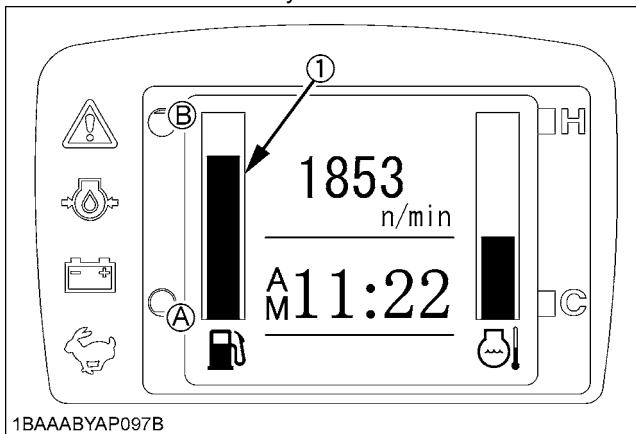

1BAAABYAP097B

- (1) Fuel gauge
 (A) "EMPTY"
 (B) "FULL"

2. If necessary, open the cap and fill in fuel.

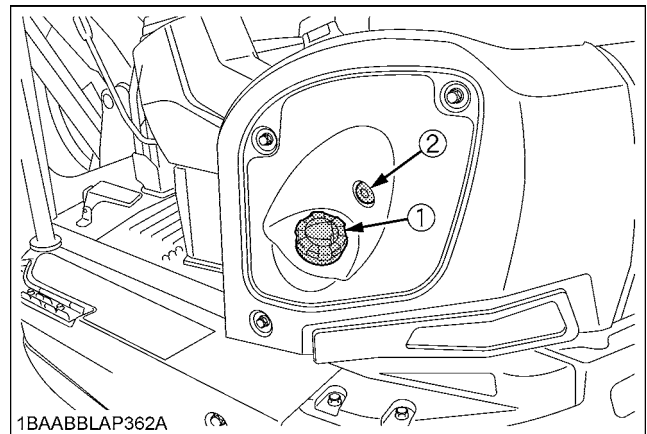

1BAABBLAP362A

- (1) Fuel tank cap
 (2) Fuel level audible indication switch

Fuel tank capacity	KX057-4	75 L
	U55-4	68 L

■Checking Engine Oil Level



CAUTION

To avoid personal injury:

- Stop the engine and remove the key before checking the oil level.

IMPORTANT :

- Use engine oil with the correct viscosity. (according to the outside temperature)
- After stopping the engine and remove the key, wait five minutes, then check oil level. (Excavator must be on level ground.)

Insert the engine oil dipstick fully into the prepared opening, remove again and check the oil level; if necessary fill with oil. The machine must be on level ground when checking the oil level.

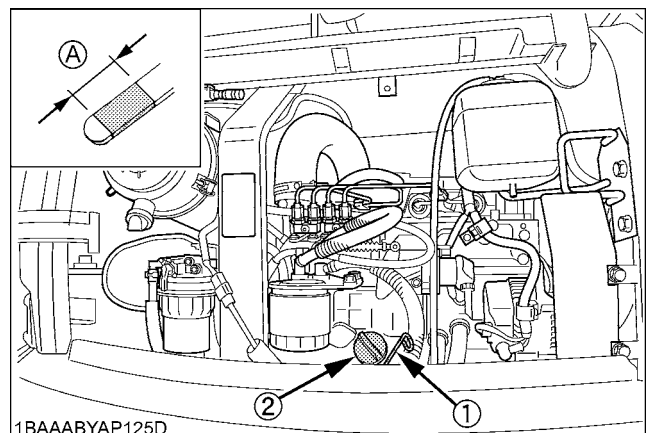

1BAAABYAP125D

- (1) Engine oil dipstick
 (2) Oil filling port
 (A) Required oil level range

■ Checking Hydraulic Oil Level



CAUTION

To avoid personal injury:

- Stop the engine and remove the key before checking the oil level.

IMPORTANT :

- Before filling oil, wipe away all sand and dust from around the oil port. Make sure to use an identical type of hydraulic fluid.
 - The excavator has been filled with hydraulic fluid before delivery. See "RECOMMENDED OILS". (Do not mix different oils.)
1. Park the excavator on a firm, flat and level surface. Lower the attachments and dozer blade to the ground and stop the engine.

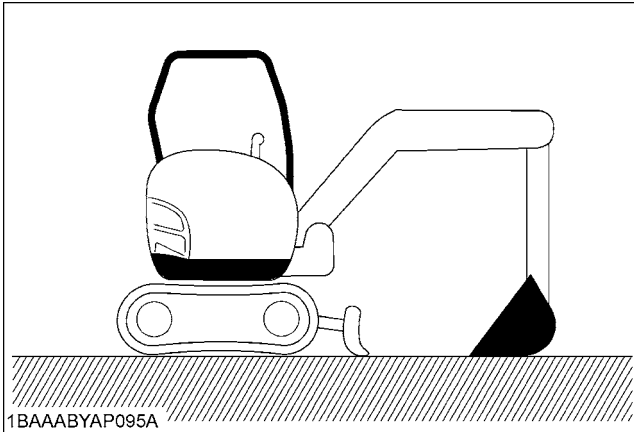

2. Check the oil level as to whether it lies on the center of the gauge at normal temperature (10 to 30 °C).
3. Enough oil is present when oil is at center mark.
4. Should the oil level be too low, loosen the oil filling plug gradually to release pressure in the tank, then fill up with oil at oil fill port.

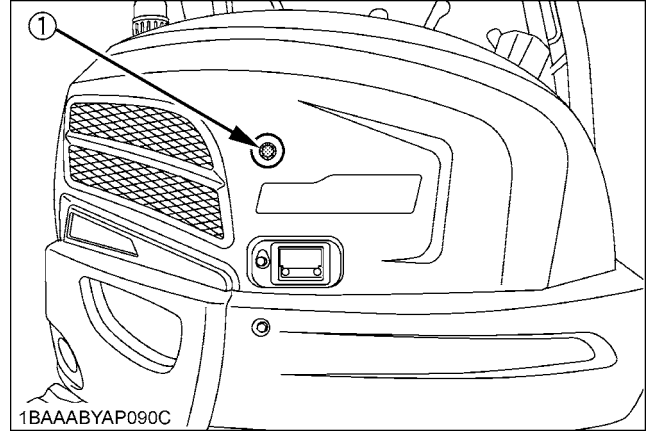

(1) Gauge

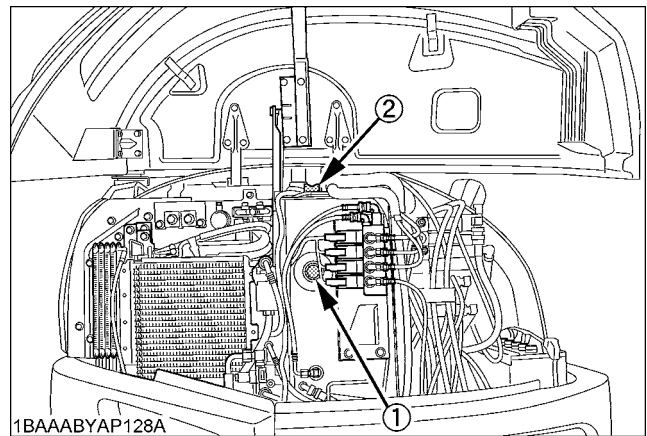

(1) Gauge
(2) Oil filling plug

■ Checking V-belt



CAUTION

To avoid personal injury:

- Stop the engine and remove the key before checking the V-belt.
- Check the V-belt for cracks and proper tension. (See "Adjusting V-belt Tension" in "REGULAR CHECKS AND MAINTENANCE WORK" section.)

■ Checking Radiator and Oil Cooler



CAUTION

To avoid personal injury;

- Always stop the engine and remove the key before checking the radiator.
- Wear eye protection when cleaning with compressed air.
- Replace all water hoses every two years.
- Inspect all water hoses daily.

Have the excavator repaired immediately if any of the following defects are discovered.

(Such defects may cause burns or injury. They may also cause engine failure or serious engine damage.)

- Scratches, cracks or swelling in water hoses.
- Water leaks at joints or connecting points.
- Missing or damaged water hose protective sleeve or grommet.
- Loose mounting bolt, damaged bracket.
- Do not touch the water hoses or the heater with your hand. You may get burned.
- If the window fails to defrost in extreme conditions or becomes cloudy when dehumidifying the CAB, remove moisture with soft cloth.
- Never block all of the air outlets, system malfunction may occur.

1. Check to see if the condenser fins are clogged with dirt. If so, loosen the bolts and tilt the condenser. Remove the dirt using compressed air or a hose. Tilt down the stopper in the direction to the locked position. When cleaning, wear eye protection. Tilt down the oil cooler by loosening the two bolts to clean easily.
2. Check the rubber hoses for damage and replace if cracked or old. Check if the hose clamps are tight enough.

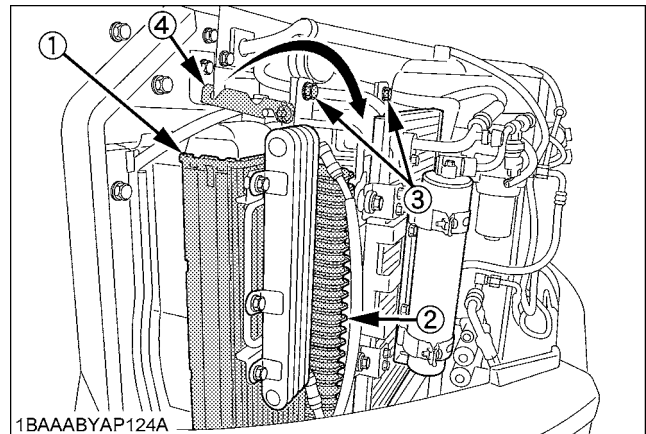

- 1BAAABYAP124A
- (1) Radiator
 - (2) Oil cooler
 - (3) Bolt
 - (4) Stopper

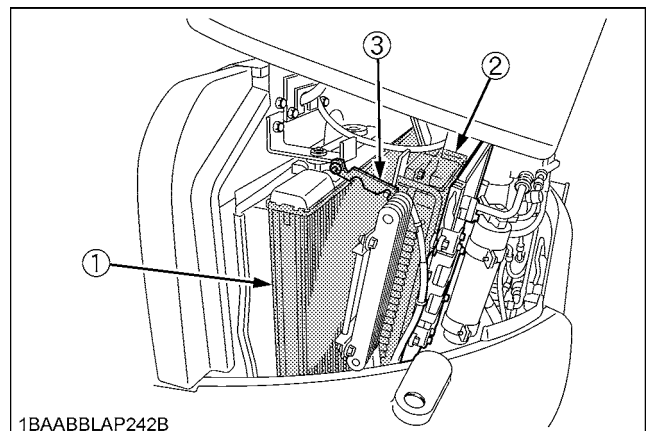

- 1BAABBLAP242B
- (1) Radiator
 - (2) Oil cooler
 - (3) Stopper

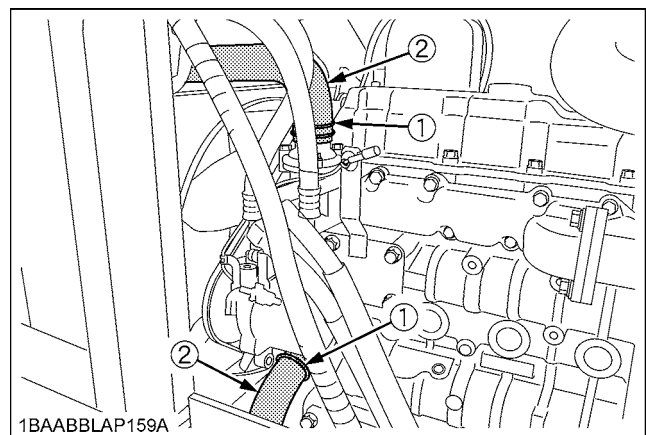

- 1BAABBLAP159A
- (1) Hose clamp
 - (2) Rubber hose

IMPORTANT :

- Radiator and oil cooler fins and ribs must be clean in order to avoid overheating the engine and to allow free flow of air through the cooling elements.
- Pressure of compressed air must be under 205 kPa (2.1 kgf.cm², 30 psi)

■Checking Washer Liquid

If the windows washer is switched on with the washer liquid tank empty, the motor may be damaged. Always keep the tank filled.

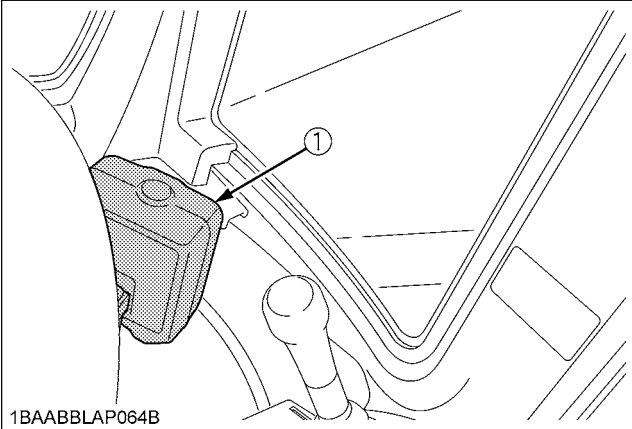

(1) Washer liquid tank

■Cleaning Pre-Cleaner

To clean the pre-cleaner, remove the wing nut and remove the pre-cleaner bowl.

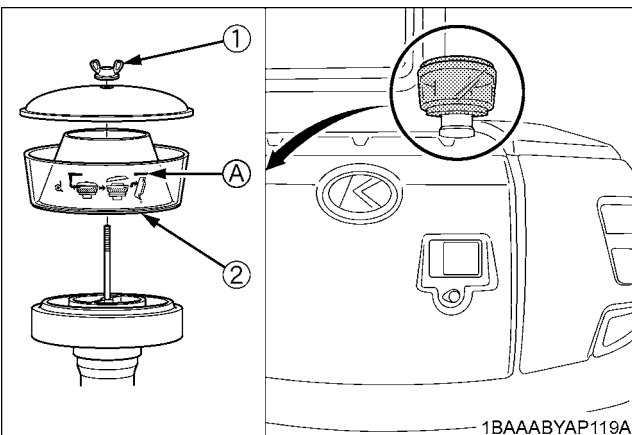

(1) Wing nut
(2) Pre-cleaner bowl

(A) "DUST LEVEL"

■Checking and Cleaning Engine and Electrical Wiring



CAUTION

To avoid personal injury:

- Always stop the engine and remove the key before cleaning the wiring, cables and engine.

Before starting, check whether flammable substances have gathered on the battery, the cables and wiring, the muffler or on the engine. Remove thoroughly. Check the electrical circuitry for disconnections, shorts or loose terminals.

■Greasing Boom Swing Fulcrum

Grease the marked grease nipples shown by arrows in the illustration below.

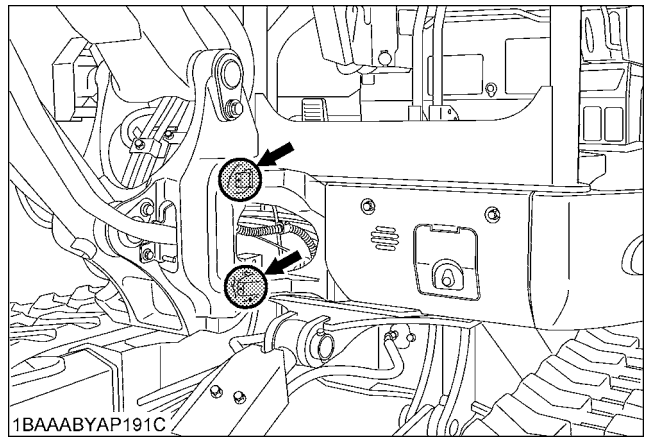

■Washing Whole Machine

IMPORTANT :

- Do not wash the excavator with the engine running. Water could enter the air filter and damage the engine. Make sure that the air filter is kept dry.
- Remove the mud before washing the machine.

■ Greasing Front Attachments (without Bucket Pin and Boom Swing Fulcrum)

CAUTION

To avoid personal injury:

- First lower all attachments on the ground then stop the engine and remove the key.
- While greasing, take care not to step on the bucket teeth.

IMPORTANT :

- When doing excavation work in water, generously grease the following points. After ending work, grease again.

Grease the marked grease nipples shown by arrows in the illustration below.

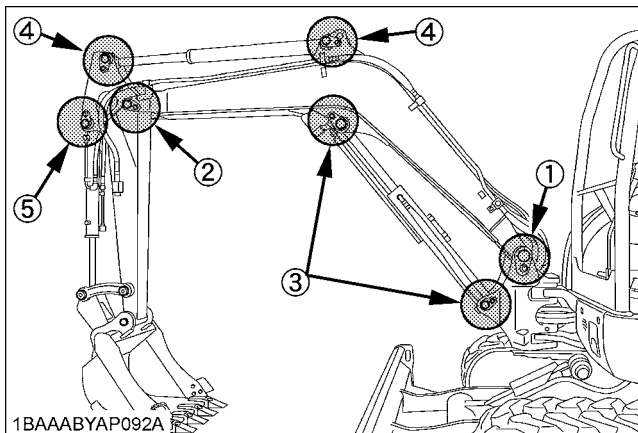

- (1) Boom bottom linkage
- (2) Arm bottom linkage
- (3) Boom cylinder boss
- (4) Arm cylinder boss
- (5) Bucket cylinder boss

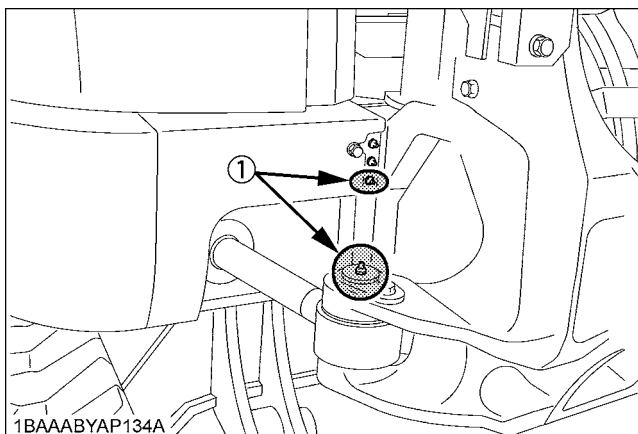

- (1) Swing cylinder boss

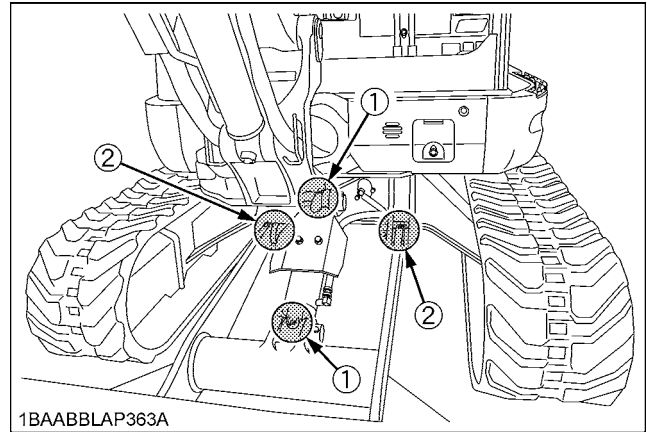

- (1) Dozer cylinder boss
- (2) Dozer linkage pin

■ Greasing Bucket Pin and Bucket Link Pin

CAUTION

To avoid personal injury:

- First lower all attachments on the ground then stop the engine and remove the key.
- While greasing, take care not to step on the bucket teeth.

IMPORTANT :

- When doing excavation work in water, generously grease the following points. After ending work, grease again.

Grease the marked grease nipples shown by arrows in the illustration below.

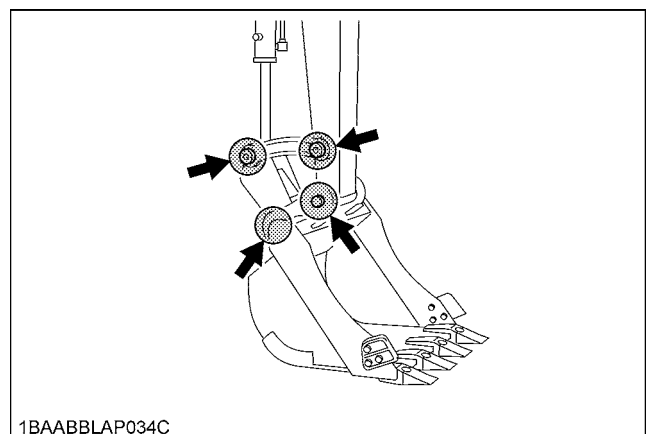

- (1) Bucket link pin
- (2) Fixing pin between arm and bucket

REGULAR CHECKS AND MAINTENANCE WORK



CAUTION

To avoid personal injury:

- When operating, keep hands and body inside of the ROPS / FOPS protective envelope.
- Do not touch the control levers and the pedals from outside the cab during the engine running.

EVERY 50 SERVICE HOURS

■ Draining Fuel Tank



CAUTION

To avoid personal injury:

- Before draining the fuel tank, be sure to stop the engine and remove the key.
- Do not smoke during inspection.

1. Open the cover.
2. Open the drain cock.

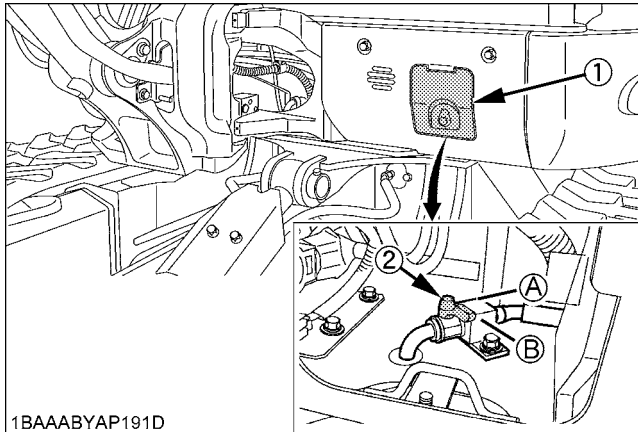

1BAAABYAP191D

- | | |
|----------------|-----------|
| (1) Cover | (A) Open |
| (2) Drain cock | (B) Close |

■ Draining Water Separator

[Checking and Draining]

Water and dirt contained in fuel will settle down in the water separator. When such foreign substances are deposited, set the water separator handle to the "CLOSE" position. Loosen the top screw first and then the bottom cock to let the foreign substances out of the separator.

Finally be sure to air-bleed the fuel system.

[Cleaning]

1. Set the water separator handle to the "CLOSE" position.
2. Loosen and remove the cup proper, and clean its inside with light oil.
3. Tighten up the cup proper.

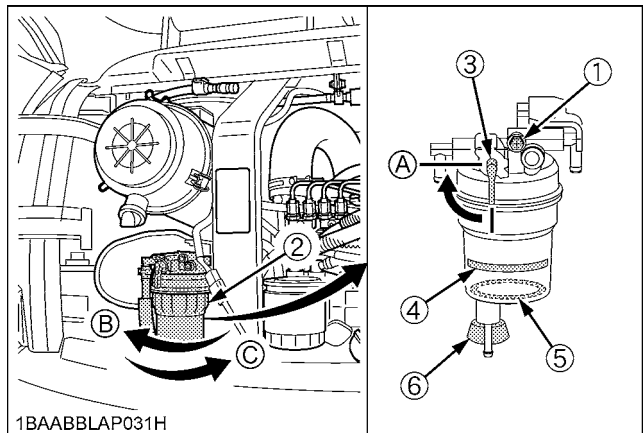

1BAABBLAP031H

- | | |
|----------------------------|-------------|
| (1) Screw | (A) Close |
| (2) Cup | (B) Loosen |
| (3) Water separator handle | (C) Tighten |
| (4) Line | |
| (5) Float | |
| (6) Cock | |

IMPORTANT :

- As water is collected, the red float goes up. When the float has reached the specified line, immediately drain the water separator.
- In reattaching the water separator, be careful to keep off dust and dirt.
- Be sure to purge the fuel system before getting the machine restarted.
(See "PURGING OF THE FUEL SYSTEM" in "OTHER CHECKS AND REPLACEMENTS" section.)

■ Battery



DANGER

To avoid the possibility of a battery explosion:
For refillable type battery, follow the instructions below.

- Do not use or charge the refillable type battery if the fluid level is below the LOWER (lower limit level) mark. Otherwise, the battery component parts may prematurely deteriorate, which may shorten the battery's service life or cause an explosion. Check the fluid level regularly and add distilled water as required so that the fluid level is between the UPPER and LOWER levels.

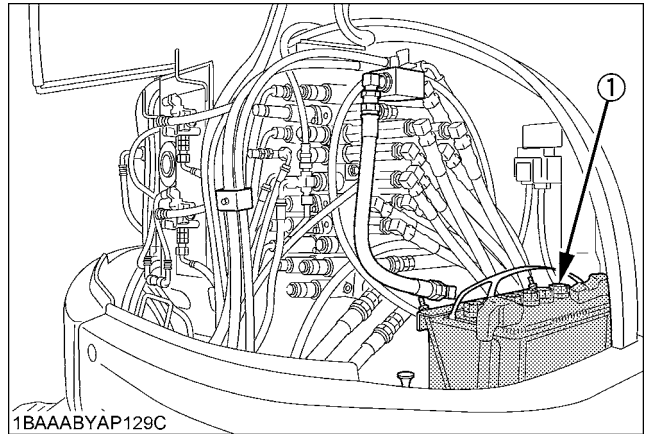

(1) Battery



CAUTION

To avoid personal injury:

- Never remove the vent caps while the engine is running.
- Keep electrolyte away from eyes, hands and clothes. If you are splattered with it, wash it away completely with water immediately and get medical attention.
- Wear eye protection and rubber gloves when working around the battery.
- Before inspection or dismantling the battery, be sure to turn off the engine and turn the starter switch to the "OFF" position.
- When removing the battery, always disconnect the negative ground cable first. When installing a battery, always connect the ground cable last. This prevents a possible explosion caused by sparks.
- Always wear eye protection when working with the battery.

1. Open the side cover. (See "Opening / Closing of the Side Cover in "MAINTENANCE" section.)
2. Check the battery fluid level and add distilled water if necessary.
3. Should battery fluid be spilled, fill with sulphuric acid solution of the same concentration.
4. Clean the battery caps (ventilation holes).

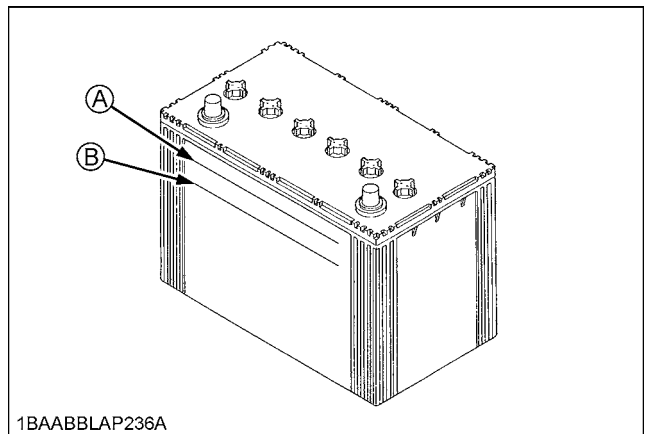

(A) "Upper level"
(B) "Lower level"

■ Battery Charging



CAUTION

To avoid personal injury:

- When the battery is being activated, hydrogen and oxygen gases in the battery are extremely explosive. Keep open sparks and flames away from the battery at all times, especially when charging the battery.
- When charging battery, remove battery vent plugs.
- When disconnecting the cable from the battery, start with the negative terminal first. When connecting the cable to the battery, start with the positive terminal first.
- Do not check battery charge by placing a metal object across the terminals. Use a voltmeter or hydrometer.

1. Make sure each electrolyte level is to the bottom of vent wells, if necessary add distilled water in a well-ventilated area.
2. The water in the electrolyte evaporates during recharging. Liquid shortage damages the battery. Excessive liquid spills over and damages the excavator body.
3. To slow charge the battery, connect the battery positive terminal to the charge positive terminal and the negative to the negative, then recharge in the standard fashion.
4. A boost charge is only for emergencies. It will partially charge the battery at a high rate and in a short time. When using a boost-charged battery, it is necessary to recharge the battery as early as possible. Failure to do this will shorten the battery's service life.
5. When the specific gravity of electrolyte falls between 1.27 and 1.29 charge has completed.
6. When exchanging an old battery for a new one, use a battery of equal specification.

■ Greasing Swing Bearing Teeth

1. Pump grease with the grease gun through the grease nipple.
2. Grease at each 90° (1.58 rad.) position of the swing frame.
3. Fill with approx. 50g of grease (approx. 20 to 30 pumps with the grease gun at each position). Distribute the grease over the teeth.

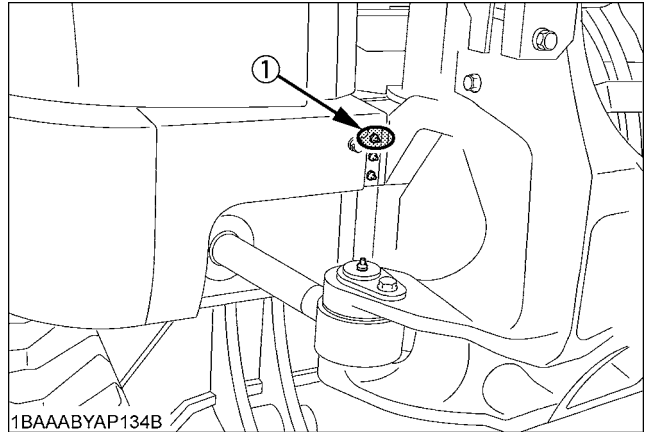

(1) Grease nipple (for swing bearing teeth)

EVERY 200 SERVICE HOURS

Do all 50 and 100 hour servicing at the same time.

■ Adjusting V-belt Tension**CAUTION**

To avoid personal injury:

- First stop the engine and remove the key.
- After servicing, make sure to replace the belt cover in its original position.

◆ Checking and adjustment of the air-conditioner belt tension

1. Press the air-conditioner belt down in the middle, with a force of approx. 58.8 to 68.6 N (6 to 7 kgf). The belt tension is correct if it deflects about 7 to 9 mm. If otherwise, loosen bolt of the tension pulley and shift the tension pulley in the direction shown by the arrow.
2. Replace the air-conditioner belt if worn out, cracked or torn.

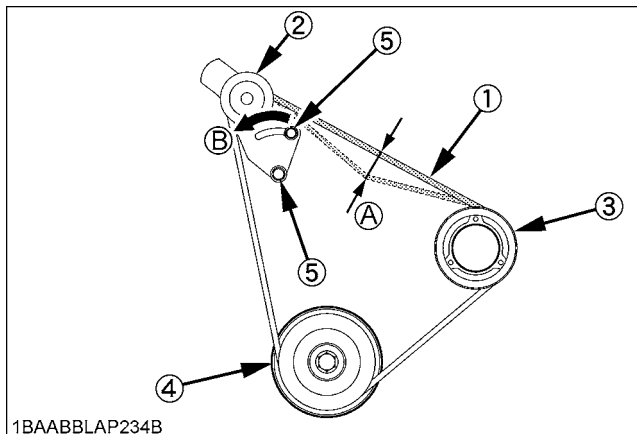

- | | |
|--------------------------------|---------------|
| (1) Air-conditioner belt | (A) 7 to 9 mm |
| (2) Tension pulley | (B) Tighten |
| (3) Air-conditioner compressor | |
| (4) Pulley | |
| (5) Bolt | |

IMPORTANT :

- If the engine is run with a loose air-conditioner belt, the belt could slip and cause insufficient battery charging. Check air-conditioner belt tension regularly.
- Should the air-conditioner belt break or jump off, the indicator light for battery charge will light up. Stop the engine and remove the key immediately.

◆ Checking and adjustment of the fan belt tension

1. Press the fan belt down in the middle, with a force of approx. 68.6 N (7 kgf). The belt tension is correct if it deflects about 12 to 15 mm. If otherwise, loosen bolt and shift the alternator in the direction shown by the arrow.
2. Replace the fan belt if worn out, cracked or torn.

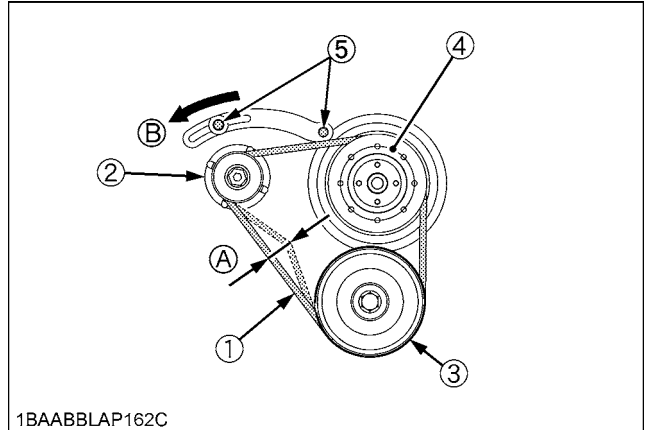

1BAABBLAP162C

- | | |
|------------------|-----------------|
| (1) Fan belt | (A) 12 to 15 mm |
| (2) Alternator | (B) Tighten |
| (3) Pulley | |
| (4) Fan pulley | |
| (5) Bolt and nut | |

IMPORTANT :

- If the engine is run with a loose fan belt, the belt could slip and cause overheating of the engine. Check fan belt tension regularly.

■ Checking Radiator Hoses and Clamps



CAUTION

To avoid personal injury:

- Wait long enough for the radiator coolant to cool down.

Check the coolant hoses for proper connection. This check should be carried out every 200 hours or every 6 months, whichever comes first.

1. Should the hose clamps become loose or coolant leaks, tighten the hose clamps properly.
2. Should the radiator hoses become swollen, aged or cracked, they must be replaced and the hose clamps tightened again properly.

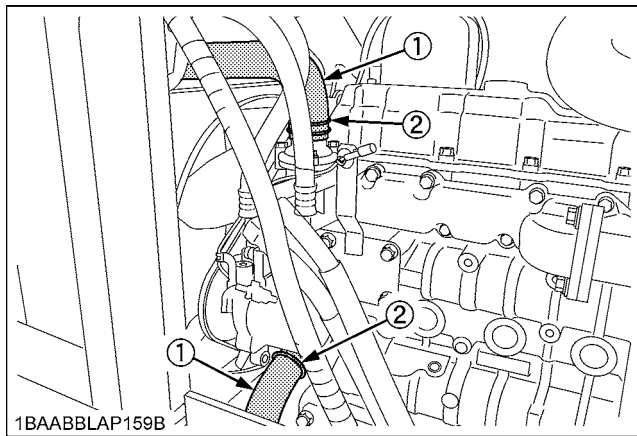

1BAABBLAP159B

(1) Radiator hoses

(2) Hose clamps

■ Inspection and Cleaning Air Filter Element

Open the engine hood and remove the dust-cover. Take out only outer element, clean the element, case interior and reassemble. During reassembly, take care to install the dust-cover so that its TOP mark (arrow) faces upwards. Do not remove the inner element.

IMPORTANT :

- Should the machine be used in extremely dusty areas, the air filter element must be inspected and cleaned more frequently than in the specified maintenance periods.
- The air filter has a dry element, keep free from oil.
- Do not run the engine without the air filter.

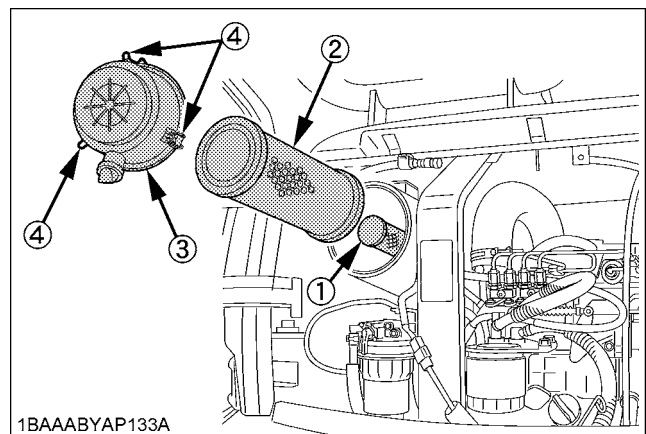

1BAAABYAP133A

- (1) Inner element
- (2) Outer element
- (3) Dust-cover
- (4) Clamps

■ Air Filter Maintenance



CAUTION

To avoid personal injury:

- Wear eye protection.

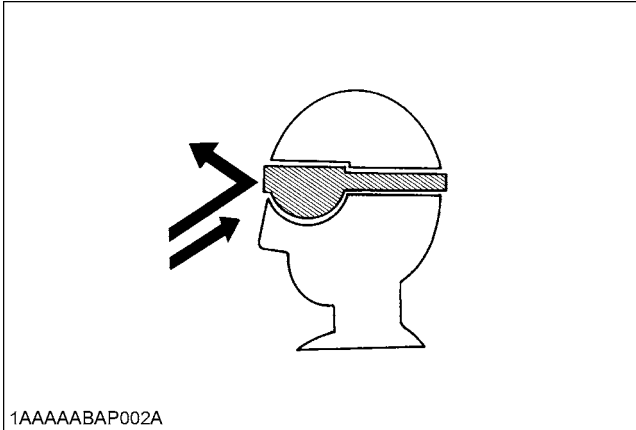

The quickest and safest method of maintenance is the exchange of the paper cartridge. Furthermore there are different methods of cleaning the cartridge.

◆ Cleaning with compressed air

Pressure of compressed air must be under 205 kPa (2.1 kgf/cm²), and the cartridge should be blown clean from the inside to the outside until the dust deposits are noticeably reduced.

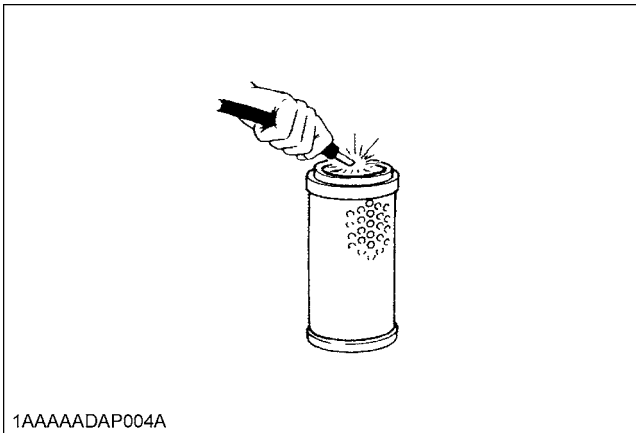

IMPORTANT :

- If the air suction is still inadequate, or the color of the exhaust gases is abnormal even after the cleaning, the air filter cartridge must be replaced.

■ Greasing Swing Ball Bearing

1. Grease through the respective grease nipple. (at the central nipple)
2. Grease at each 90° (1.58 rad.) position of the swing frame.

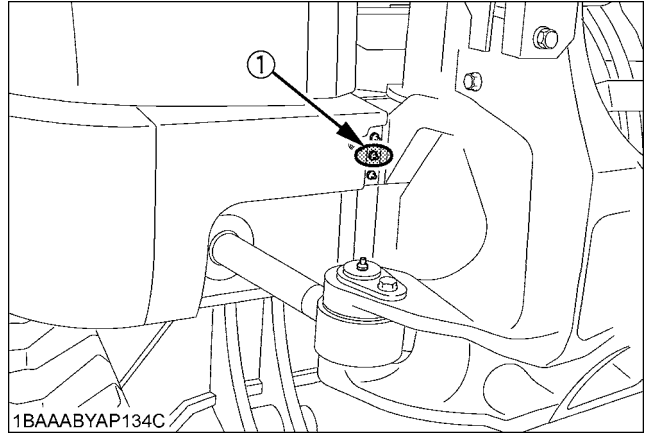

(1) Grease nipple

■ Checking Fuel Line and Intake Air Line

1. Check to see that all lines and hose clamps are tightened and not damaged.
2. If hoses and clamps are found worn or damaged, replace or repair them at once.

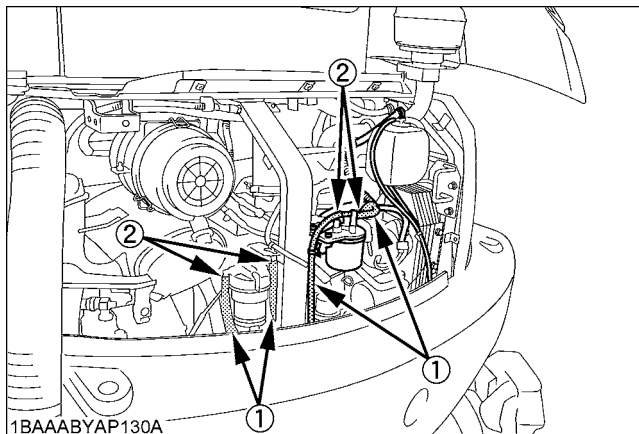

- (1) Fuel lines
- (2) Clamp bands

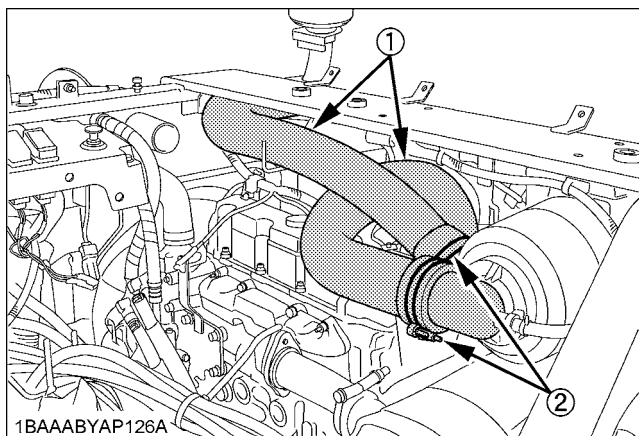

- (1) Hoses
- (2) Hose clamps

AIR CONDITIONER

■ Cleaning Air Filter

Open the cover and remove the filter cover, remove the air filter.

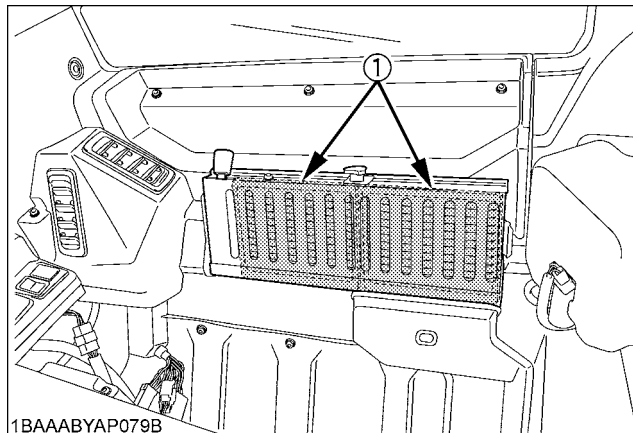

- (1) Air filter



CAUTION

To avoid personal injury:

- Wear eye protection.

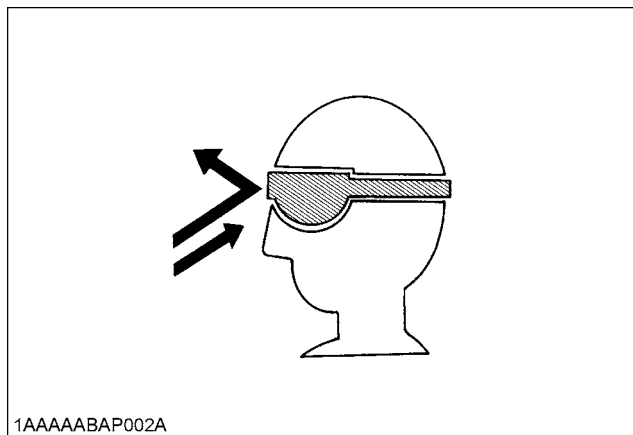

◆ Cleaning the air filter

- Normal use
 - Blow air from the opposite direction to the filter's normal air flow.

IMPORTANT :

- Do not hit the filter. If the filter becomes deformed, dust may enter into the air-conditioner, which may cause damage and malfunction.

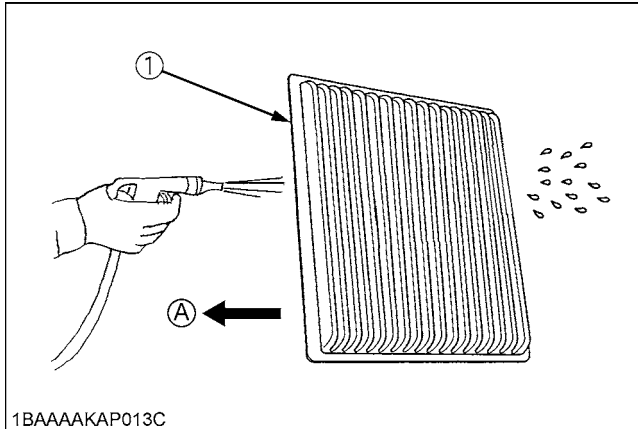

1BAAAAKAP013C

(1) Filter (A) "AIR-CONDITIONER AIRFLOW"

NOTE :

- Pressure of compressed air must be under 205 kPa (2.1 kgf/cm², 30 psi).
- If the filter is very dirty, replace the air filter.

■Checking Air-Conditioner Condenser

Check air conditioner condenser to be sure it is clean from debris.

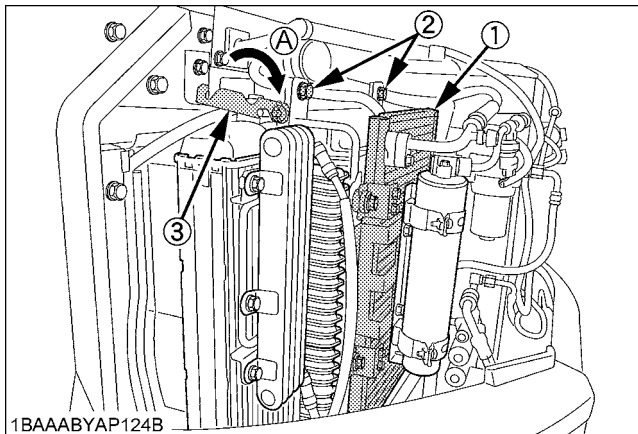

1BAAABYAP124B

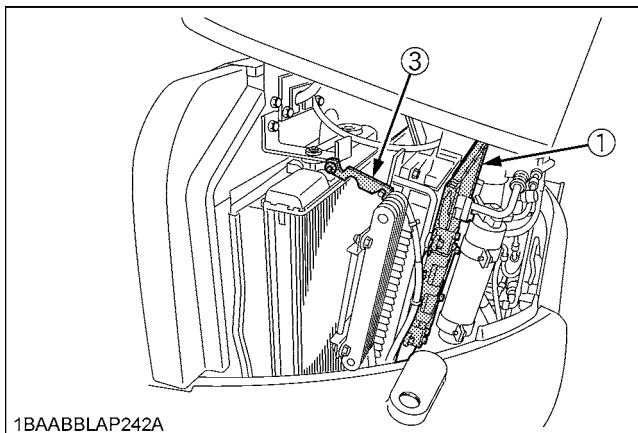

1BAABBLAP242A

(1) Air conditioner condenser (A) "LOCK"
(2) Bolt
(3) Stopper

EVERY 250 SERVICE HOURS

Do all 50 hour servicing at the same time.

■Changing Engine Oil(First Engine Oil Change after 50 Service Hours)



CAUTION

To avoid personal injury:

- First stop the engine then remove the key and wait long enough for the oil to cool down.

1. Remove the drain plug on the underside of the engine and drain all oil.
2. Re-tighten the drain plug.

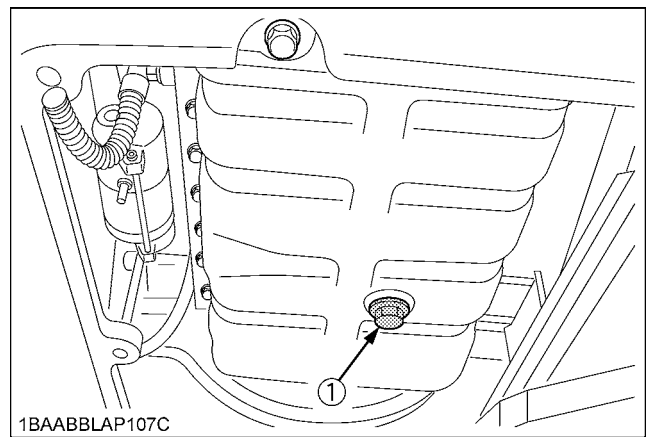

1BAABBLAP107C

(1) Drain plug

3. Fill up with new oil through the filling port to the specified level.

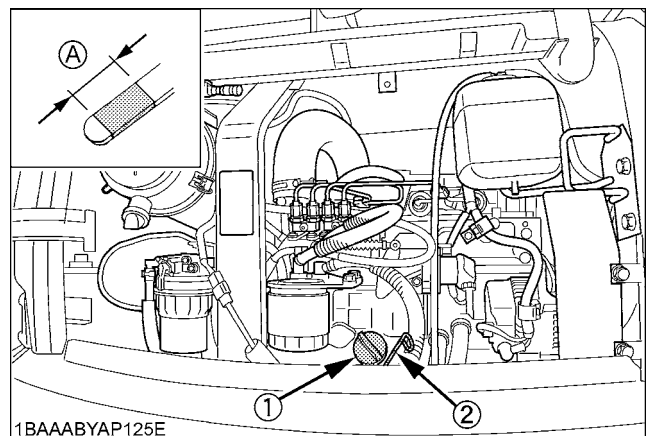

1BAAABYAP125E

(1) Oil filling port (A) Required oil level range
(2) Engine oil dipstick

- Let the engine idle for approx. 5 min. Check the engine oil level. To check the engine oil level, insert the engine oil dipstick completely into the respective port opening and pull out again. If the oil level lies between both markings, no oil must be added.

IMPORTANT :

- Regardless of the service hours, an engine oil change is due every 1 year.

Engine oil volumes (with engine oil filter)	9.0 L
--	-------

■ Replacing Engine Oil Filter

- Replace the oil filter cartridge at the same time as doing the engine oil change.
- Remove the cartridge with the supplied filter wrench.

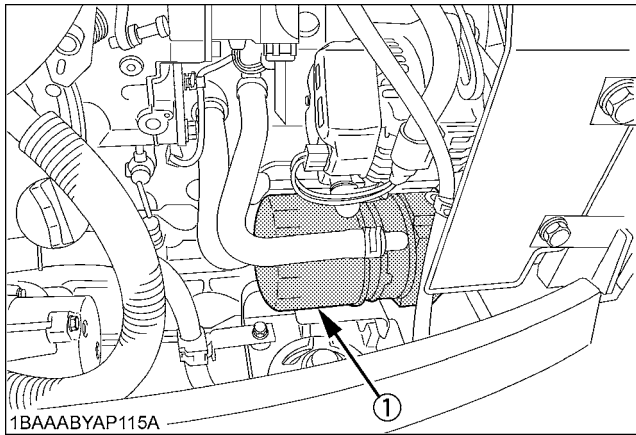

(1) Oil filter

- Oil the O-ring of the new oil filter cartridge lightly. Then tighten the oil filter cartridge by hand.
- Fill engine oil to the specified level.
- Let the engine run for approx. 5 min. and make sure that the engine oil indicator lamp does not light up. Then stop the engine and remove the key.
- The engine oil level is reduced by the amount of the filter capacity after the engine is started. It is usually necessary to add oil.

IMPORTANT :

- Always check the oil level after having exchanged the filter.

EVERY 500 SERVICE HOURS

Do all 50, 100 and 250 hour servicing at the same time.

■ Drive unit Oil Change (First Oil Change of the 50 hours)



CAUTION

To avoid personal injury:

- Lower all attachments to the ground, stop the engine and remove the key before undertaking the oil change.

- Rotate the track so that the drain plug of the drive unit is in the bottom position.
- Remove the drain plug to let the oil run out. Screw in and tighten the drain plug again and fill with gear oil through the oil check port.
- Fill oil until it overflows out of the oil check port.

Oil change

- first oil change after 50 hrs
- then every 500 hrs
- or at least once a year

- Use prescribed gear oil SAE 90.

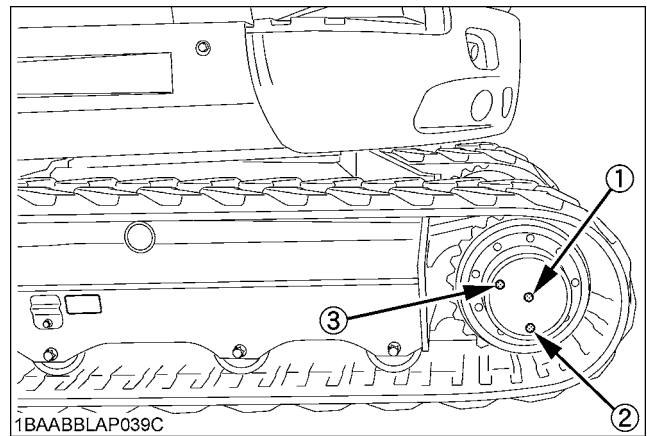

- (1) Oil check port
- (2) Drain plug
- (3) Oil filling port

Gear oil volume	approx. 0.9 L
-----------------	---------------

■ Replacing Fuel Filter Cartridge



CAUTION

To avoid personal injury:

- Keep fire away.

1. Remove the filter with the filter wrench.
2. Apply a light film of fuel to the seal of the new filter and turn in tightly by hand.
3. Open the cock of the fuel filter again.

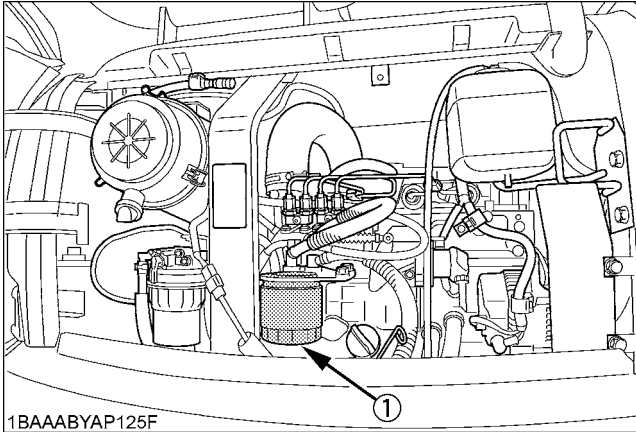

(1) Fuel filter cartridge

IMPORTANT :

- After exchange of the filter, the fuel system must be purged of air.

■ Replacing Breather Filter

See "Replacing Hydraulic Return Filter Cartridge" in "EVERY 1000 SERVICE HOURS" section.

EVERY 1000 SERVICE HOURS

Do all 50, 100, 200, 250 and 500 hour servicing at the same time.

■ Replacing the Hydraulic Pilot Filter Element



CAUTION

To avoid personal injury:

- Before replacing the element, wait long enough for the hydraulic fluid to cool down.

1. Open the side cover.
2. Remove the pilot filter case from the head cover.
3. Wrench and pull out the element downward.
4. Replace the O-ring with a new one.
5. Apply a light coating of clean hydraulic oil to the O-ring and fit it to the case firmly. Be careful not to scratch the O-ring.
6. Attach the case to the head cover firmly.
7. Let the engine run for approx. 3 minutes.
8. Check the oil level of hydraulic oil tank, then tighten the oil filling plug.

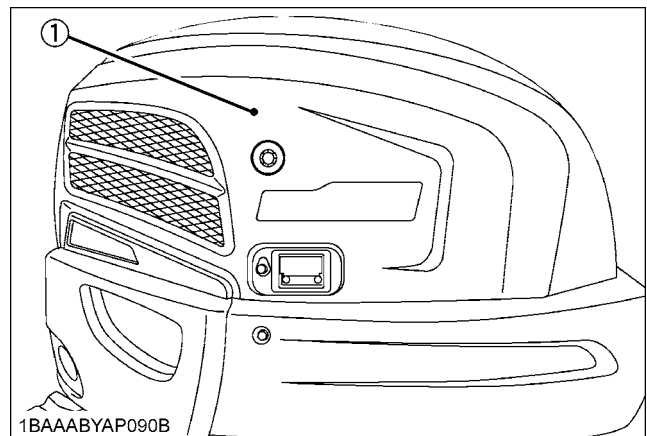

(1) Rear right cover

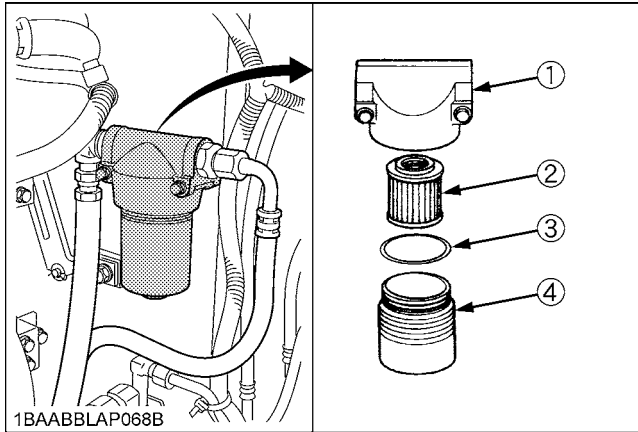

- (1) Head cover
- (2) Element
- (3) O-ring
- (4) Case

■ Replacing Hydraulic Return Filter Element



CAUTION
To avoid personal injury:

- Remove the oil filter element only after the oil in the hydraulic tank has cooled down.

1. Hold the filter support top and take the filter out of the tank.
2. Loosen the set bolt first and then detach the return filter from its support. Replace the filter with new one.
3. Remove the bolt from the cover. Take out and replace the breather filter with new one.

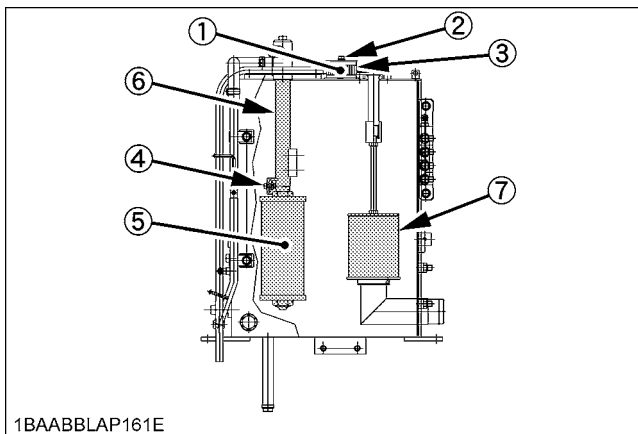

- (1) Breather filter
- (2) Bolt
- (3) Cover
- (4) Set bolt
- (5) Return filter
- (6) Filter support
- (7) Suction filter

IMPORTANT :

- Always check the oil level when replacing the filter element.

■ Hydraulic Oil Change (Including Replacing of the Suction Filter in the Hydraulic Tank)



CAUTION

To avoid personal injury:

- Wait long enough for the hydraulic fluid to cool down. Then begin with the change of the hydraulic fluid.

1. Park the excavator on a firm, flat and level surface. Lower the attachments and dozer blade to the ground and stop the engine.

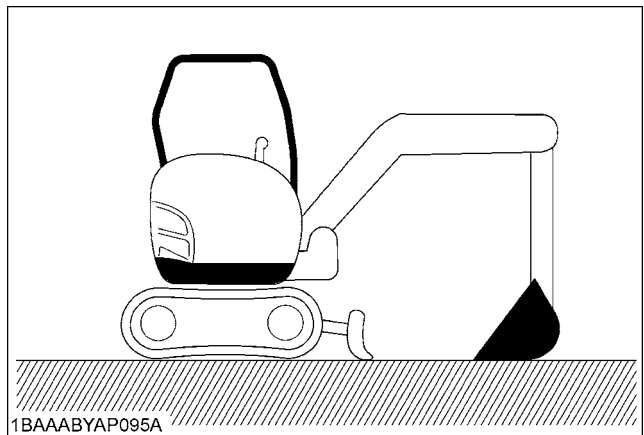

2. Remove the drain plug on the underside of the hydraulic tank and drain the oil.

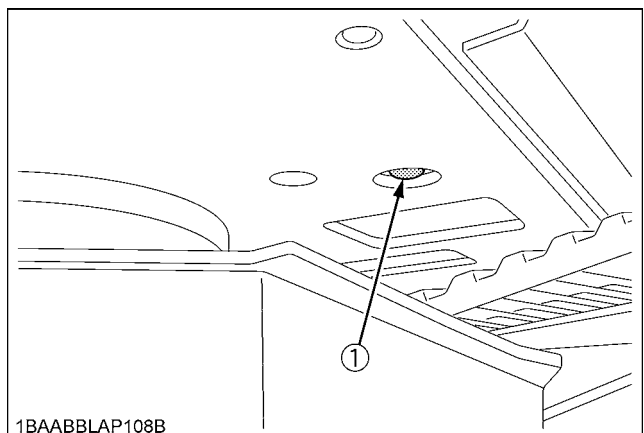

- (1) Drain plug

3. Remove the suction filter lock pin and detach the suction filter. Replace the filter with new one.

4. Retighten the drain plug.

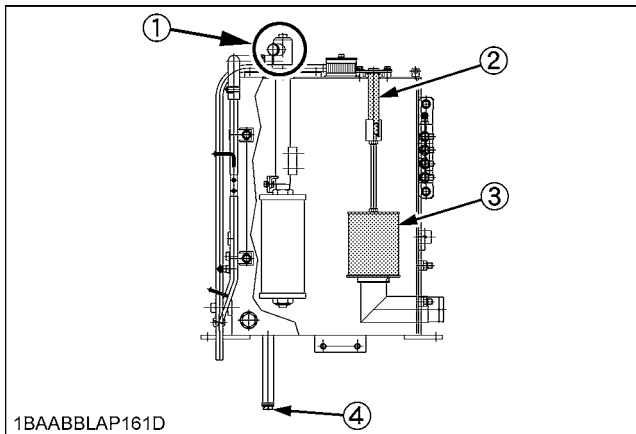

- (1) Oil filling plug
- (2) Pin
- (3) Suction filter
- (4) Drain plug

- 5. Fill oil through the oil filling opening on the top side of the tank.
- 6. Let the engine run and operate the boom, arm, bucket and boom swing device. Then bring the boom to the highest position, pull the arm, bucket inward and boom swing left end.
- 7. Fill oil again up to the center of the gauge.

Hydraulic oil volumes	Hydraulic tank	45 L
	Whole oil volumes	79 L

8. Install the hydraulic tank cover and tighten the oil filling plug.

Hydraulic Oil Check with Hydraulic Hammers

The hydraulic oil change after 1000 operating hours in the operator's manual is based on normal excavator work. Following inspection measures are valid when hydraulic hammers are used:

1. Changing and filling up of hydraulic oil
 - (1) The hydraulic oil must be changed more often when hammers are used because the machine is subject to harder conditions than normal excavating work.
 - (2) Use only the recommended oils mentioned in the operator's manual when changing or filling with oil.
 - (3) When filling up oil, do not mix oils of different makes.
2. Changing the return filter and oil
 - (1) The filter must be changed more often because of contamination resulting from the frequent assembly and disassembly of the hoses.
 - (2) Use the correct replacement filter.
 - (3) Oil change according to operating hours.

		Hydraulic oil	Return filter	Suction Filter
Normal excavator work		every 1000 Hrs.	every 1000 Hrs. (250 Hrs. after first operation)	every 1000 Hrs.
Hammer work portion	20%	every 800 Hrs.	every 800 Hrs.	
	40%	every 400 Hrs.	every 400 Hrs.	
	60%	every 300 Hrs.	every 300 Hrs.	
	more	every 200 Hrs.	every 200 Hrs.	

EVERY 1000 SERVICE HOURS OR ONCE A YEAR

■ Replacing Air Filter Element

Open the engine hood and remove the dust-cover. Remove and replace the outer element and inner element with new elements.

When reassembling, install the dust-cover so that its TOP mark (arrow) faces up-wards.

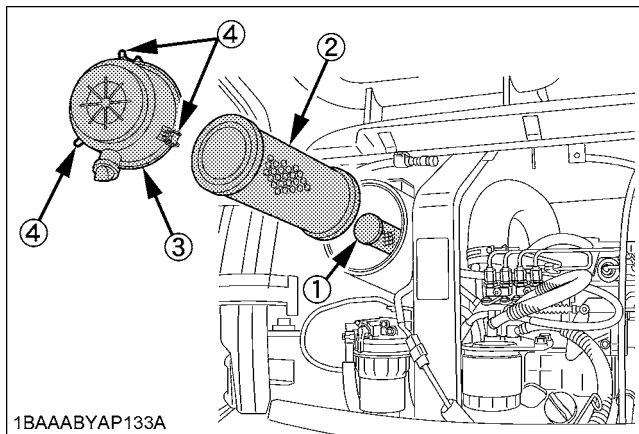

- (1) Inner element
- (2) Outer element
- (3) Dust-cover
- (4) Clamps

IMPORTANT :

- Shorten the replacement period if the machine is used in dusty or sandy areas.

EVERY 1500 SERVICE HOURS

■ Checking Fuel Injection Nozzle(Injection Pressure)

Consult your local KUBOTA Dealer for this service.

EVERY 2000 SERVICE HOURS

Do all 50, 100, 200, 250, 500 and 1000 hour servicing at the same time.

■ Changing Front Idler and Track Roller Oil

NOTE :

- Contact your KUBOTA dealer for details.

■ Checking the Alternator and Starter Motor

NOTE :

- Contact your KUBOTA dealer for details.

EVERY 3000 SERVICE HOURS

■ Checking Injection Pump

Consult your local KUBOTA Dealer for this service.

ANNUAL SERVICING

■ Electrical Wiring and Fuses

Check the terminals periodically for proper connections. Loose wiring or damaged cables can cause improper functioning or short circuiting of the electrical system. Check wiring and replace damaged components immediately. If a fuse blows out soon after having been replaced, contact your nearest KUBOTA dealer. Never use a fuse other than specified.

■ Checking the Electrical Circuit

Check the electrical circuitry for disconnections, shorts or loose terminals.

■ Checking Air-Conditioner Pipes and Hoses



CAUTION

To avoid personal injury:

- Do not touch the coolant hoses or the heater with your hand. You may get burned.

1. Check to see that all lines and hose clamps are tight and not damaged.
2. If hoses and clamps are found worn or damaged, replace or repair them at once. (Consult your local KUBOTA Dealer for this service.)

BIENNIAL SERVICING



CAUTION

To avoid personal injury:

- Do not loosen the radiator cap before the radiator has cooled down sufficiently. Only loosen the cap after allowing enough time for the pressure in the system to be reduced. Thereafter, one can remove the cap completely.

■ Replacing Air-Conditioner Pipes and Hoses



CAUTION

To avoid personal injury:

- Do not touch the coolant hoses or the heater with your hand. You may get burned.

Replace air-conditioner pipes and hoses every two years. If the hoses or pipes are swollen, hard or cracked, they must be replaced earlier.

■ Replacement of Radiator Hoses

Replace radiator hoses and hose clamps every two years. If the hoses are swollen, hard or cracked, they must be replaced earlier.

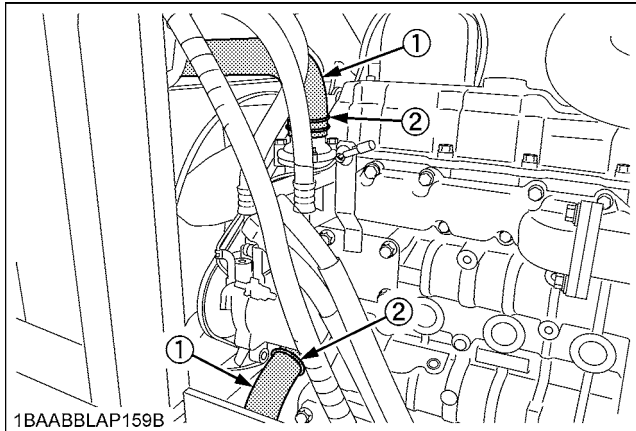

1BAABBLAP159B

- (1) Radiator hoses
- (2) Hose clamps

■ Changing Radiator Coolant



CAUTION

To avoid personal injury:

- When using anti-freeze, use protective clothing such as rubber gloves (Anti-freeze is poisonous.).
- If you accidentally swallowed anti-freeze, seek medical attention at once.
- When anti-freeze comes in contact with the skin or clothing, wash it off immediately.
- Do not mix different types of Anti-freeze. The mixture can produce a chemical reaction causing harmful substances.
- Anti-freeze is extremely flammable and explosive under certain conditions. Keep fire and children away from anti-freeze.
- When draining fluids from the engine, use a container underneath the engine body to catch the fluids.
- Do not pour waste onto the grounds, down a drain, or into any water source.
- Also, observe the relevant environmental protection regulations when disposing of anti-freeze.
- If swallowed, anti-freeze is poisonous to people, animals and birds.

Stop the engine then remove the key and wait until it has cooled down completely.

1. Open the drain plug on the bottom of the radiator and drain coolant completely, Should a recovery tank be equipped, disconnect the line from the tank floor and then open the drain cock.
2. To clean, rinse the radiator with water.
3. Close the drain plug and fill the radiator and the recovery tank with coolant fluid. Let the engine idle for about 5 min., stop the engine and remove the key.
4. Check the coolant level of recovery tank and add the coolant if necessary.
5. The machine has been shipped filled with 50% anti-freeze solution.

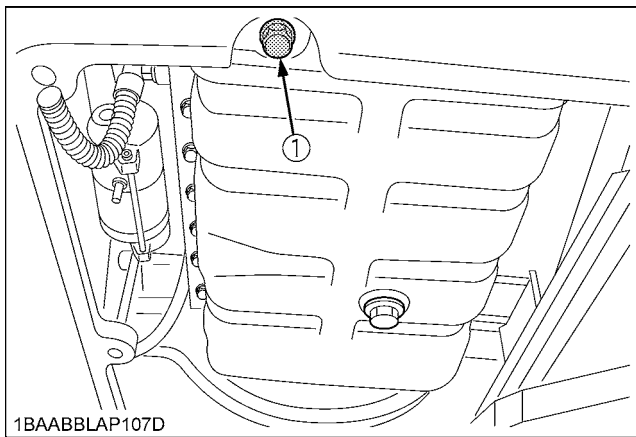

(1) Drain plug

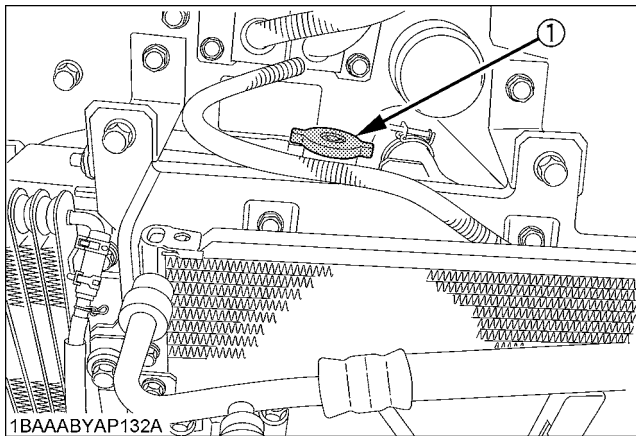

(1) Radiator cap

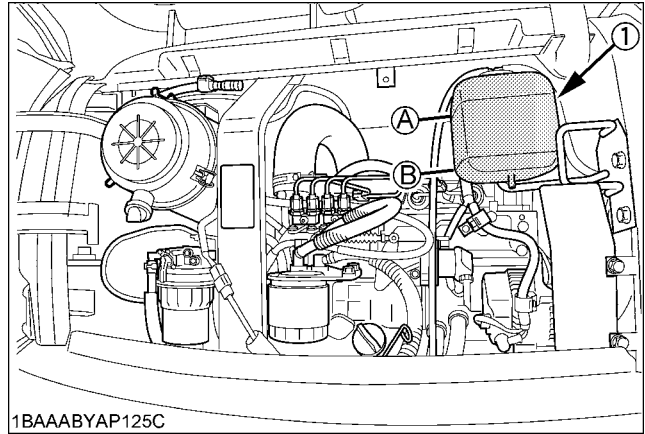

(1) Recovery tank

(A) "FULL"
(B) "LOW"

Cooling water	Canopy	Approx. 7.8 L
	Cabin	Approx. 8.1 L

IMPORTANT :

- Do not operate the engine without coolant.
- To fill the radiator system and the recovery tank, use fresh water and anti-freeze fluid.
- When the anti-freeze is mixed with water, the anti-freeze mixing ratio must be less than 50%.
- Tighten the radiator cap properly. If the cap is loosely or not properly fitted, overheating of the engine can result due to coolant fluid loss.

■ Replacing Fuel Hose

Replace the hoses and clamps.

(See "Checking Fuel and Intake Air Line" in "EVERY 200 SERVICE HOURS")

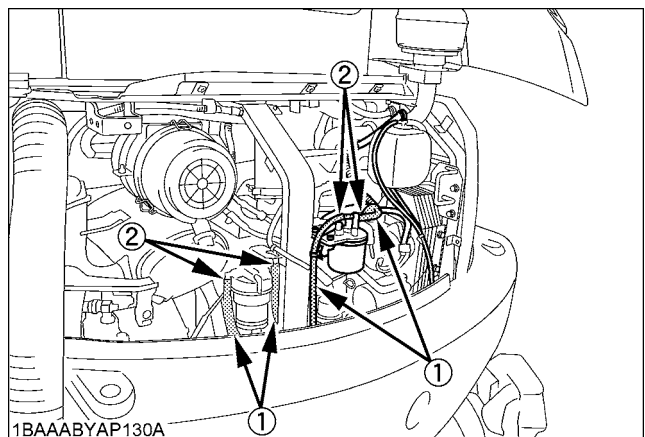

(1) Fuel lines

(2) Clamp bands

■ Replacing Intake Air line

Replace the hoses and clamps, if necessary.
(See "Checking Fuel and Intake Air Line" in "EVERY 200 SERVICE HOURS")

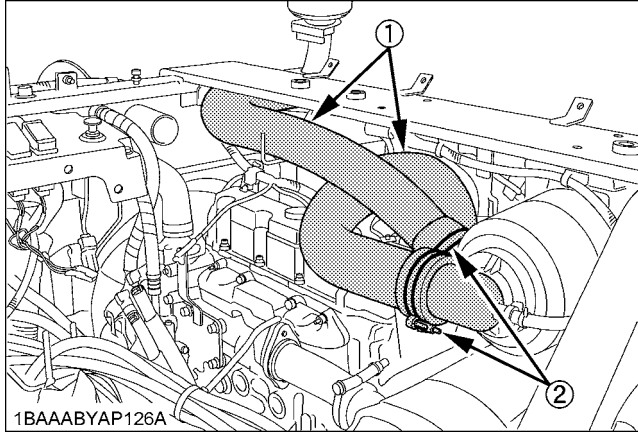

- (1) Hoses
- (2) Hose clamps

SERVICING AS REQUIRED

■ Checking Amount of Refrigerant (gas)



WARNING

To avoid personal injury:

- Liquid contact with eyes or skin may cause frostbite.
- In the event of a leakage, wear safety goggles. Escaping refrigerant can cause severe injuries to eyes.
- In contact with a flame, R134a refrigerant result in a toxic gas.
- Do not disconnect any part of the refrigeration circuit of the air conditioning system. Consult your local KUBOTA Dealer for assistance and service.

A shortage of refrigerant reduces the air-conditioner performance. Check the following points. If it is indicated that the amount of refrigerant is extremely low, ask your dealer to inspect and charge.

◆ Checking procedure

1. Run the air-conditioner in the following conditions.
 - Engine speed: About 1500 rpm
 - Temperature control lever: Maximum cooling position (rightmost)
 - Fan switch: Highest blow (3)
 - Air-conditioner switch: ON

2. Look into the sight glass to see if the refrigerant is flowing through its circuit.

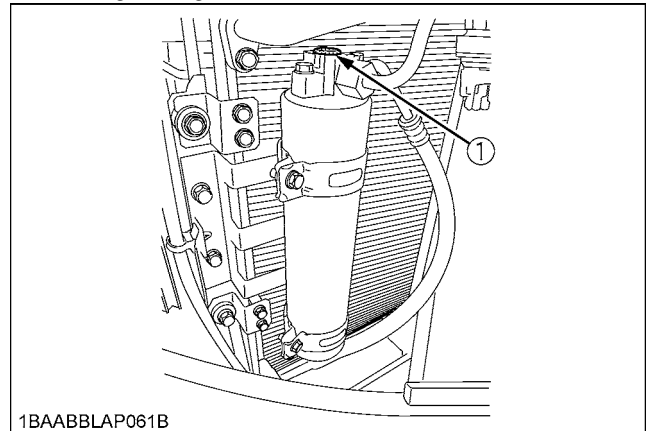

(1) Sight glass

	Proper	Little or no air bubbles in the refrigerant flow.
	Low	Lots of air bubbles in the refrigerant flow (air bubbles or foam passing continuously).
	Overfull of no refrigerant	Colorless and transparent.

1BAAAAP012A

IMPORTANT :

- Charge only with R134a not R12 refrigerant (gas).

OTHER ADJUSTMENTS AND REPLACEMENTS

PURGING OF THE FUEL SYSTEM

1. Fill up the excavator with fuel.
2. Turn the starter key to the position "RUN".
3. The air in the fuel system will automatically be purged within one minute.

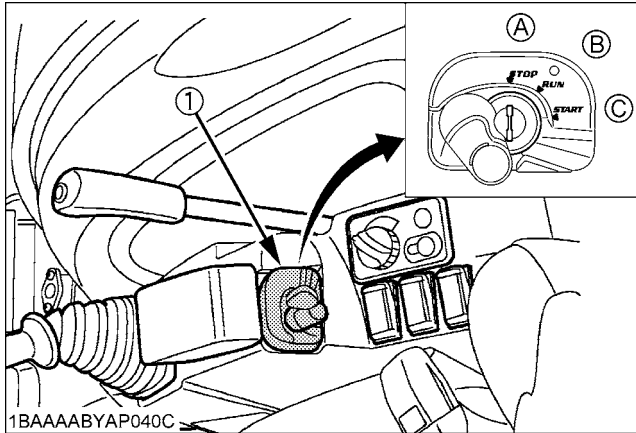

(1) Starter switch

(A) "STOP"
(B) "RUN"
(C) "START"

IMPORTANT :

- If the purging was insufficient, the engine dies right after starting. In this case repeat steps 2 to 3 again.

ADJUSTMENT OF TRACKS

- ◆ To loosen the tracks, follow the following procedure:



CAUTION

To avoid personal injury:

- Do not loosen the grease nipple completely or too quickly. Otherwise grease under high pressure in the tension cylinder could squirt out.
 - Do not crawl under the excavator.
1. Loosen the bolts and remove the cover.
 2. Using a socket wrench, loosen the grease nipple a few turns.
 3. When grease oozes out from the thread, rotate the track and loosen the track in the lifted position (see illustration).

After adjustment is completed:

Using the socket wrench, tighten the grease nipple. Tightening torque must be between 98 to 108 N-m.

IMPORTANT :

- If the tracks are too tight, wear is increased.
- If the tracks are too loose, the track pads may collide with the sprocket and wear is increased. The track may dislocate or come off.
- Clean the track after every use.
- Should the track tension be high due to sticking mud, lift the track with the help of the boom, arm and bucket, idle the engine and remove mud from the track by rotating it.

◆ Tension the tracks as specified:

1. Loosen the bolt and remove the cover.
2. Apply grease to the grease nipple.

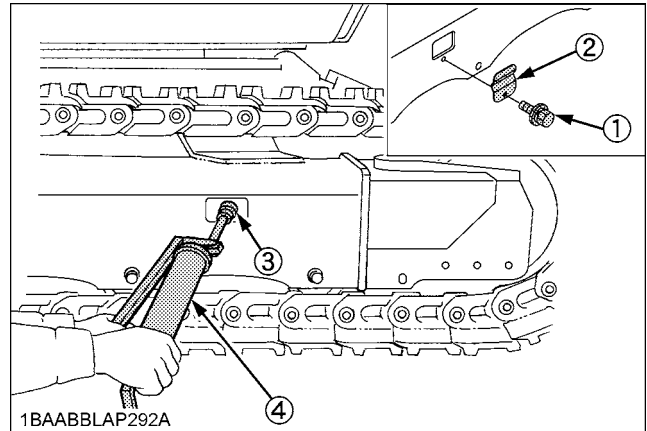

- (1) Cover
- (2) Bolt
- (3) Grease nipple
- (4) Grease gun

3. Rubber Tracks

Tension the track in the lifted position, so that the distance "A" (clearance between the track roller and the inside surface of the track) see illustration, in this case, if there is a seam mark "∞" on the inside surface of the track, the seam mark "∞" is positioned on the top center between the idler and the sprocket.

Steel Tracks

To check the track tension, the track must be lifted from the ground as shown. The track tension is correct if the clearance between the outer end of the track roller and the track interior surface corresponds to the dimension specified in the table below.



DANGER

To avoid serious injury or death:

- Do not work under the machine in this condition.
- For your safety do not rely on hydraulically supported devices, they may leak down and suddenly drop or be accidentally lowered.



WARNING

To avoid personal injury or death:

- When lifting the machine itself with an attachment, place a safety block or safety post to prevent the machine from turning over. Keep the lock lever for attachment control in the "LOCK" position.

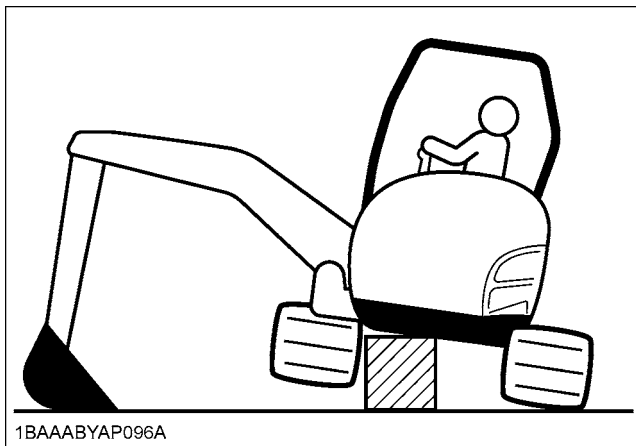

1BAAABYAP096A

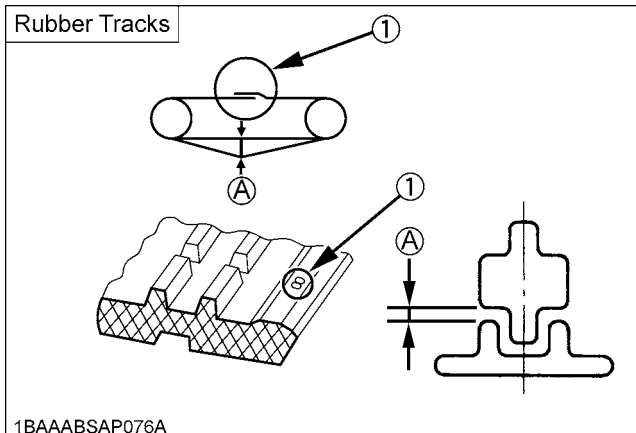

1BAAABSAP076A

(1) Seam (Mark "∞")

(A)	10 to 15 mm
-----	-------------

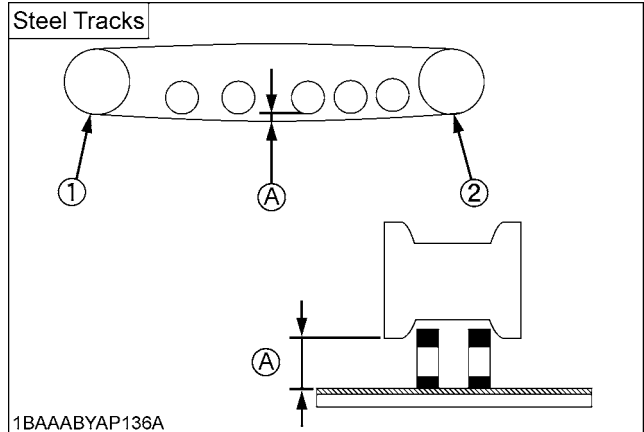

1BAAABYAP136A

- (1) Drive sprocket
- (2) Idler

(A)	80 to 85 mm
-----	-------------

IMPORTANT :

- Make sure that no obstacles, such as stones are caught in the track. Remove such obstacles before adjusting the track tension.
- Track seam
The ends of the rubber track are joined with a seam. When adjusting the tracks, the seam must be positioned on the top midway between the idler and the sprocket.

If the seam is positioned incorrectly, the tracks will be tensioned too loosely, and a further readjustment will be necessary.

- Rotate the track after adjustment one to two times to check the tension.
- Additionally following points are to be observed when adjusting rubber tracks.
 - (1) If the track loosen more than 50 mm, readjust them.
 - (2) Check track tension 50 hours after initial use and readjust if necessary. Check and adjust thereafter every 50 service hours.

Special Information when Using Rubber Tracks

1. When turning, make a slow swing turn. Avoid spin turns to reduce lug wear and entry of dirt.
2. The relief valve may be activated if too much dirt and sand clog the tracks. In this case move the machine for a short distance straight backwards to let the earth and sand fall off, then a turn can be made.
3. Avoid using rubber track on riverbeds, stony underground, ferro-concrete and on iron plates. The rubber can damage as well as increase wear on the tracks.

CHANGING THE BUCKET



CAUTION

To avoid personal injury:

- There are two people required to replace the bucket. One person operates the excavator, and the other one mounts the bucket. The person who mounts the bucket must command-guide the movements of the front end attachments. The operator should move the front end attachments only according to the commands of the person who mounts the bucket. Continuous visibility between both persons is indispensable. If there is no visibility, stop working immediately.
- When replacing the bucket, make sure to wear eye protection, a helmet and protective gloves.
- During attaching and detaching, chippings and burns may occur at the bolts or bushings. These may cause severe injuries.
- Never use your fingers for the alignment of the components (linkage, bucket, arm). The components may sever your fingers by uncontrolled movements.
- Read the manual of the attachment to do a correct operation safely when other attachments are installed instead of Kubota specified bucket.

FUSES



CAUTION

To avoid personal injury:

- When changing fuse, stop the engine and turn the key in position "STOP". Keep the lock lever for attachment control in the "LOCK" position.

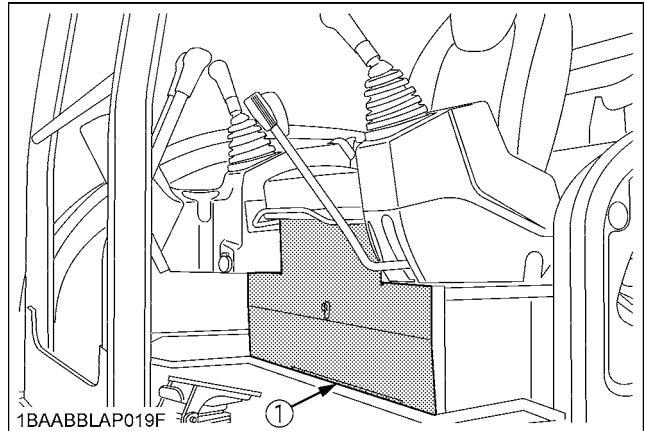

(1) Cover

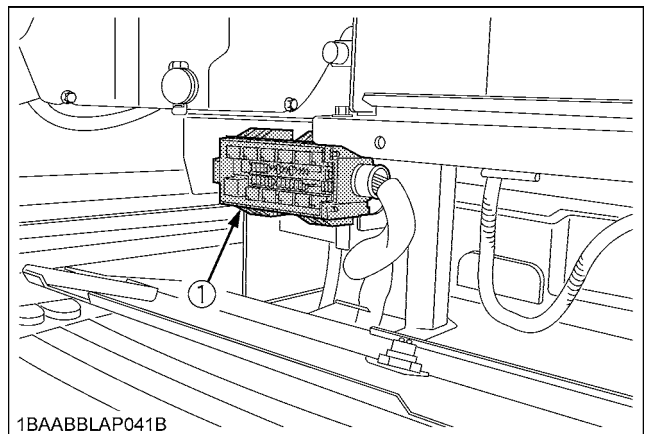

(1) Fuse box

■ Replacing Fuses

1. Remove the cover of the fuse box.
2. Replace the burnt out fuse with a fuse having the same capacity.

■ Fuse Capacities and Circuits

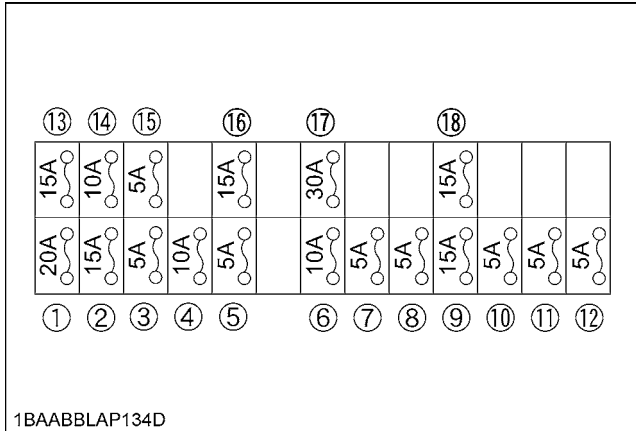

[Canopy]

1	Cab Light	10	Fuel Pump
2	Work Light	11	Lever Lock
3	Meter (+B)	12	Starter
4	Horn	13	AI Motor
5	Room Light	14	Horn SW
6	Alternator	15	ECU (+B)
7	Cab Relay	16	Beacon
8	Meter (AC)	17	Engine Stop
9	ECU (AC)	18	Electrical Outlet

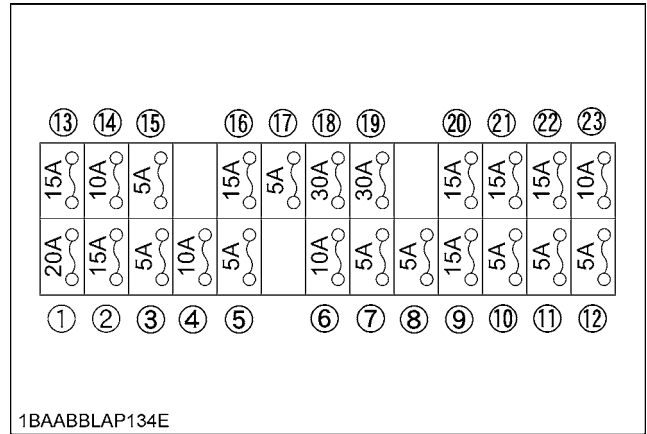

[CAB (Air-conditioner type)]

1	Cab Light	13	AI Motor
2	Work Light	14	Horn SW
3	Meter (+B)	15	ECU (+B)
4	Horn	16	Beacon
5	Room Light	17	A/C Controller (+B)
6	Alternator	18	Engine Stop
7	Cab Relay	19	Blower Motor
8	Meter (AC)	20	Electrical Outlet
9	ECU (AC)	21	Radio (AC)
10	Fuel Pump	22	Wiper / Washer
11	Lever Lock	23	Compressor, A/C Controller (AC)
12	Starter		

■ Auxiliary Electric

Max power is less than 110 W including the equipped light 55W.

If you need another auxiliary electric, contact your KUBOTA dealer for details.

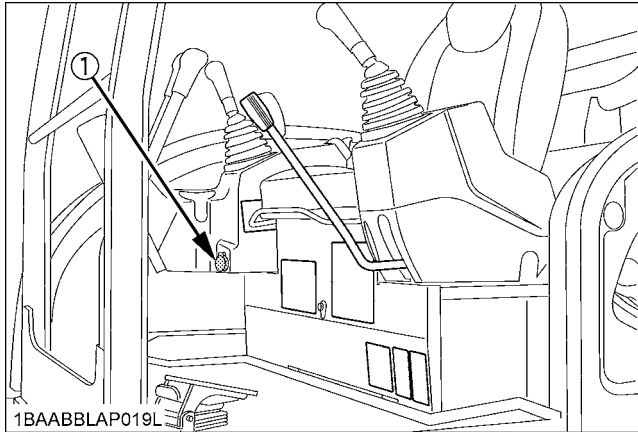

(1) Auxiliary Electric

■ Slow Blow Fuse

Slow blow fuse is provided to protect the electrical circuits. If the fusible link is blown, check the electrical circuits for trouble and then replace with a new compatible slow blow fuse.

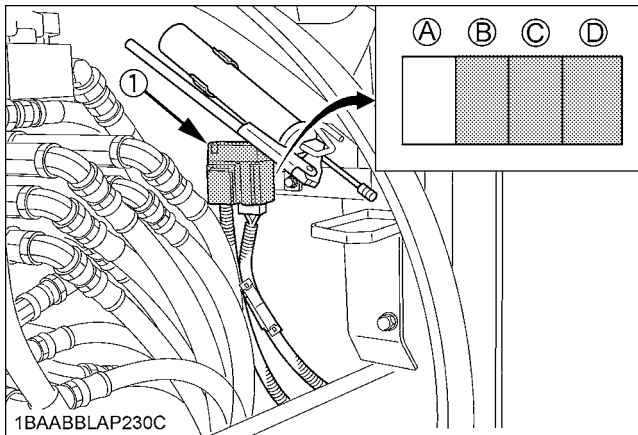

(1) Slow blow fuse

(A)	
(B)	80A Alternator
(C)	50A Main Power
(D)	50A Engine Stop Cab Relay (Blower Motor)

◆ Replacement procedure [80 Amp. Slow-blow fuse]

1. Disconnect the negative cord of the battery.
2. Remove the slow blow fuse case.

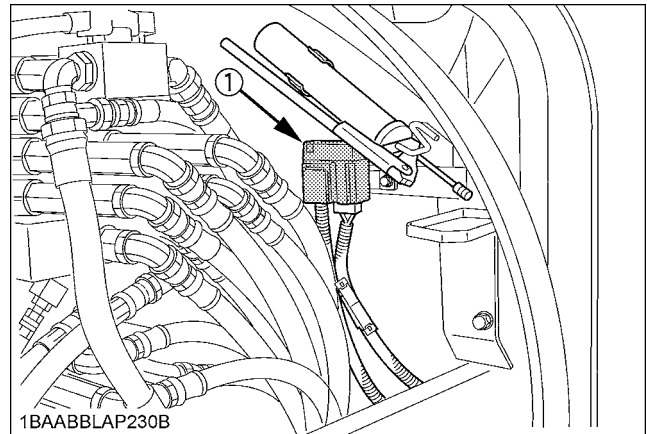

(1) Slow blow fuse case

3. Open the slow blow fuse case cap and cover then remove the bolts and draw out the slow blow fuse (B).

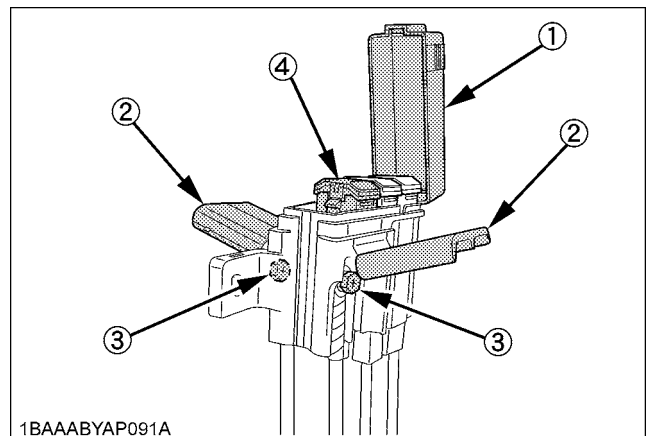

- (1) Slow blow fuse case cap
- (2) Cover
- (3) Bolt
- (4) Slow blow fuse (B)

TROUBLESHOOTING

If the excavator does not show the desired performance, or when trouble arises, refer to the table below and undertake appropriate measures.

Trouble		Cause	Countermeasure
Engine	Starting difficulties	Lock levers in "UNLOCK" position	* Bring lock lever into "LOCK" position.
		Fuel is too viscous.	* Check fuel tank and filter. * Remove impurities and water. * If necessary, replace filter.
		Air or water in the fuel system	* Remove water from the fuel tank. * Check fuel pipe joint bolts and nuts for looseness. * Purging of the fuel system (for fuel filter and injection pump, see "PURGING OF THE FUEL SYSTEM" in the chapter. "OTHER ADJUSTMENTS AND REPLACEMENTS".)
		Oil viscosity is too high the engine runs sluggishly in winter.	* Pour hot water over the radiator.
		Battery is almost dead; insufficient compression.	* Recharge battery.
	Insufficient engine power	Low fuel level	* Check fuel and add if necessary.
		Clogged air cleaner	* Clean the air filter element.
	Engine suddenly stops.	Low fuel level	* Check fuel and add if necessary. * Purge the fuel system.
	Abnormal exhaust gas color	Poor fuel	* Use high quality fuel.
		Too much engine oil	* Drain engine oil to prescribed oil level.
	Water temperature in red zone (Overheating)	Defective seal of the water pump	* Replace.
		Worn or torn V-belt	* Adjust or replace.
		Thermostat is defect.	* Replace.
		Coolant level too low	* Fill to prescribed level.
		Radiator grill or fins are clogged.	* Clean.
Coolant is contaminated with rust from the cylinder head or crank case.		* Replace coolant fluid and add anti-rust.	
Defective radiator cap (Evaporation)		* Replace.	
Corroded coolant pipes		* Clean.	
Continuous operation under full load	* Reduce load.		

Trouble		Cause	Countermeasure
Engine	Water temperature in red zone (Overheating)	Cylinder head gasket is damaged (Coolant loss).	* Replace.
		Engine oil level too low	* Fill to prescribed level.
		Maladjustment of fuel injection	* Readjust ignition timing.
		Use of poor fuel	* Use prescribed fuel.
Hydraulic System	Boom, arm, bucket, drive, swing and dozer power is too low.	Hydraulic oil level too low	* Add oil.
		Leakages of hoses and / or joints	* Replace hose or joint.
	Swing motor and front attachment does not work.	Lock lever in "LOCK" position	* Bring lock lever into "UNLOCK" position.
Drive System	Deviation of drive direction	Blocked through stones	* Remove.
		Track too loose or too tight	* Adjust accordingly.
AI	System indicator light flashes.	Fuse in fuse box defective	* Replace the fuse.

OPERATION UNDER COLD WEATHER CONDITIONS

PREPARATION FOR OPERATION IN COLD WEATHER

1. Replace engine oil and hydraulic oil with those of viscosities suitable for cold weather.
2. In cold weather, battery power drops, and the battery fluid may freeze if the battery is not sufficiently charged. To prevent the battery fluid from freezing, be sure to keep the battery charged at least 75% or more of its capacity after operation. To ease next starting, it is recommended to keep the battery stored in closed or heated rooms. If the battery fluid level is too low, do not add after operation, but add with the engine running before the next operation.
3. Add anti-freeze to coolant in the radiator and recovery tank, if the ambient temperature is expected to drop below 0°C (32°F). Mixing ratio of water and anti-freeze depends on the expected ambient temperature. When mixing, stir it up well, and then fill into the radiator.

- Mixing ratio between water and anti-freeze

Ambient Temperature °C	-5	-10	-15	-20	-25	-30	-35
Antifreeze %	30	30	30	35	40	45	50
Water %	70	70	70	65	60	55	50

IMPORTANT :

- Use permanent anti-freeze or long-life coolant.
- Drain the coolant completely and clean the radiator inside then fill with the water and anti-freeze mixture.
- As the anti-freeze also acts as an anti-corrosive, it is not necessary to add an additive to the water and anti-freeze mixture.
- See "Coolant check" under "DAILY CHECKS" in "MAINTENANCE" for radiator fill volumes.

PROCEDURE AFTER DONE WORK

Clean the excavator thoroughly after work and wipe dry. Otherwise mud and earth on the tracks could freeze if the temperature drops below the 0°C (32°F) mark. Operation of the excavator is then not possible. Store the excavator in a dry place; if not possible, store on wooden planks or on mats. If the excavator is kept on damp or muddy ground, the tracks could freeze overnight. Operation of the excavator is then not possible. Furthermore the reduction gear may be damaged.

Additionally, the piston rods of the hydraulic cylinders must be rubbed dry. Otherwise severe damage could occur if dirty water seeps through the seals.

LONG STORAGE



CAUTION

To avoid personal injury:

- Do not clean the excavator with the engine running.
- To avoid the danger of exhaust fume poisoning, do not operate the engine in a closed building without proper ventilation.
- When storing, remove the key from the starter switch to avoid unauthorized persons from operating the excavator and getting injured.
- Bring the excavator on a firm, flat, and level surface. Lower the attachments and dozer blade on the ground.

■ Should the Excavator be Stored for a Longer Period of Time, Observe Following Procedures:

1. The whole excavator should be cleaned thoroughly and in all cases stored indoors. If the excavator has to be kept outdoors, lay out wooden planks on even ground, place the excavator on the planks and cover completely.
2. Do an oil change and grease the excavator.
3. Heavily grease the visible section of the cylinder rods.
4. Remove the battery and store indoors.
5. If it is expected that the temperature will sink below the 0°C mark, add anti-freeze or drain coolant completely.

IMPORTANT :

- Wash the excavator after stopping the engine.
If you wash the excavator while running the engine, splashing water gets into the air cleaner through its intake and cause engine damage.
Carefully, wash and do not splash water over the air cleaner while the engine is running.

■ Observe Following Procedures when the Machine is to be Operated after Long Storage.

1. Wipe off the grease from the hydraulic cylinder rods.
2. Turn on the engine and operate the attachments and the drive mechanisms under no load in order to circulate the hydraulic oil.
(If the machine is stored for longer than one month, do steps 1 and 2 once every month.)

Periodic replacement of important component parts

To ensure safety in operation, you are strongly requested to inspect and service the machine at regular intervals. For added safety, ask your KUBOTA dealer to replace the following important component parts.

These parts are prone to degradation in material or subject to wear and tear with time. It is difficult to judge how much they have been affected at regular inspection. It is therefore necessary to replace them with new ones, whether wear is visible or not after a specified time of use.

If any of them is found worn even before the specified use, it must be repaired or replaced the same way as other parts.

If any of the hose clamps is found deformed or cracked, the hose clamp must also be replaced.

For the hydraulic hoses other than the ones to be replaced periodically, inspect them for the following points. If found unusual condition, tighten them up, replace them.

When replacing the hydraulic hoses, change their O rings and sealings with new ones.

For replacement of the important parts, contact your KUBOTA dealer.

- At the following periodic inspections, check the fuel hoses and hydraulic hoses as well.

Inspection Interval	Check points
Daily Checks	Oil leak at fuel and hydraulic hose connections and points
Every month	Oil leak at fuel and hydraulic hose connections and points Damages at fuel and hydraulic hose (cracks, chafing)
Every year	Oil leak at fuel and hydraulic hose connections and points Interference, deformation, degradation, twist and other damages (cracks, chafing) of fuel and hydraulic hoses

List of important component parts

No.	Component parts	Used place	Q'ty	Period
1	Fuel hose	Fuel tank - Water separator	1	Every 2 years or 4000 hours
		Water separator - Fuel pump	1	
		Fuel pump - Fuel filter	1	
		Fuel filter - Fuel nozzle	1	
		Fuel nozzle - Fuel cooler	1	
		Fuel cooler - Fuel tank	1	
2	Hydraulic hose (suction)	Tank - Pipe, Suction	1	
		Pipe, Suction - Main Pump	1	
3	Hydraulic hose (delivery)	Main pump - Control valve	3	
		Main pump - Pilot filter	1	
		Pilot filter - Unload valve	1	
4	Hydraulic hose (Boom cylinder)	Control valve - Boom cylinder	2	
5	Hydraulic hose (Arm cylinder)	Control valve - Pipe, Boom	2	
		Pipe, Boom - Arm cylinder	2	
6	Hydraulic hose (Bucket cylinder)	Control valve - Pipe, Boom	2	
		Pipe, Boom - Bucket cylinder	2	
7	Hydraulic hose (Swing cylinder)	Control valve - Swing cylinder	2	
8	Hydraulic hose (Dozer cylinder)	Control valve - Rotary joint	2	
		Rotary joint - Pipe	2	
		Pipe - Dozer cylinder	2	
9	Hydraulic hose (Service port)	Control valve - Pipe, Boom	4	
		Pipe, Boom - Pipe, Boom	4	
		Pipe, Boom - Pipe, Arm	4	
10	Hydraulic hose (Swivel motor)	Control valve - Swivel motor	2	
11	Hydraulic hose (Travel motor)	Control valve - Rotary joint	4	
		Rotary joint - Travel motor	4	
12	Hydraulic hose (Angle cylinder)	Control valve - Rotary joint	2	
		Rotary joint - Pipe	2	
		Pipe - angle cylinder	2	

To prevent serious damage to the hydraulic system, use only a KUBOTA genuine hydraulic hose.

RECOMMENDED OILS

IMPORTANT :

1. Before delivery the hydraulic oil used was an ISO 46 viscosity grade.
2. Use engine oil API service classification CD, CE or CF.
3. Use SAE 90 (API, CLA/GL5) as drive unit oil for all seasons.

	Application	Viscosity	Shell	Mobil	Exxon	MIL-Standard
Engine oil	In winter or by low temperatures	SAE 10W	Shell Rotella T10W Shell Rimula 10W	Mobil Delvac 1310	XD-3 10W XD-3 Extra 10W	MIL-L-2104C MIL-L-2104D
		SAE 20W	Shell Rotella T20W-2 Shell Rimula 20W-2	Mobil Delvac 1320	XD-3 20W-20 XD-3 Extra 20W-20	
	In summer or by high ambient temperatures	SAE 30	Shell Rotella T30 Shell Rimula 30	Mobil Delvac 1330	XD-3 30 XD-3 Extra 30	
		SAE 40	Shell Rotella T40 Shell Rimula 40	Mobil Delvac 1340	XD-3 40 XD-3 Extra 40	
		SAE 50	Shell Rimula 50	Mobil Delvac 1350		
All- Season engine oil	Multi-purpose	Shell Rotella T15W-40		XD-3 15W-40 XD-3 Extra 15W-40		
Gear oil	In winter or by low temperatures	SAE 75		Mobilube HD80W-90		MIL-L-2105C
		SAE 80	Shell Oil S8643	Mobilube HD80W-90		
	In summer or by high ambient temperatures	SAE 90		Mobilube 46		MIL-L-2105
			Shell Spirax HD90	Mobilube HD80W-90		MIL-L-2105C
		SAE 140		Mobilube HD85W-140		MIL-L-2105C
			Shell Spirax HD140	Mobilube HD80W-140		MIL-L-2105C
All-weather gear oil	Multi-purpose	Shell Spirax HD80W Shell Spirax HD85W	Mobilube HD80W-90	GX80W-90	MIL-L-2105C	
Hydraulic oil	In winter or by low temperatures	ISO 32	Shell Tellus T32	Mobil DTE-Oil 13	NUTO H32	
		ISO 46	Shell Tellus T46	Mobil DTE-Oil 15	NUTO H46	
	In summer or by high ambient temperatures	ISO 68	Shell Tellus T68	Mobil DTE-Oil 16	NUTO H68	
Grease			Shell Alvania EP2	Mobilux EP2	BEACON Q2	
Fuel			Light oil No. 2-D (ASTM D975)			
Fuel under -5°C (+23°F)			Light oil No. 1-D (ASTM D975)			

APPENDICES

MAIN DIMENSIONS

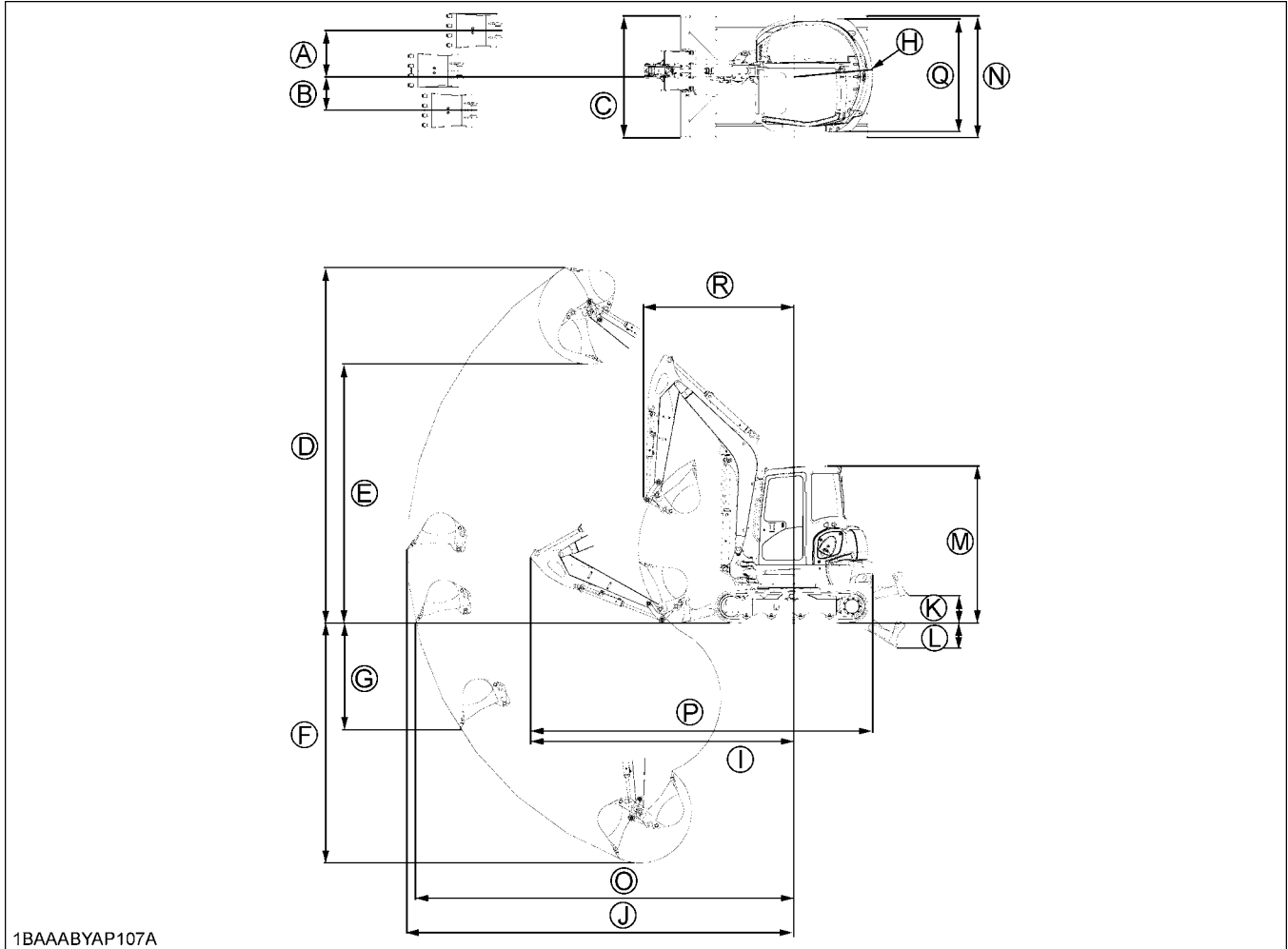

mm

	(A)	(B)	(C)	(D)	(E)	(F)	(G)	(H)	(I)	(J)
KX057-4	750	550	1960	5740	4180	3865	1710	1270	4250	6240
	(K)	(L)	(M)	(N)	(O)	(P)	(Q)	(R)		
KX057-4	440	410	2550	1960	6110	5520	1830	2420		
	(A)	(B)	(C)	(D)	(E)	(F)	(G)	(H)	(I)	(J)
U55-4	815	625	1960	5580	4020	3615	1515	1045	4310	6080
	(K)	(L)	(M)	(N)	(O)	(P)	(Q)	(R)		
U55-4	440	410	2550	1960	5945	5500	1830	2460		

NOTE :

- Above dimensions are based on the machine with KUBOTA original bucket.
- Above dimensions are based on the machine with rubber track.
- Specifications subject to change without notice.

LIFTING CAPACITY

- The lifting capacities are based on ISO 10567 and do not exceed 75% of the static tilt load of the machine or 87% of the hydraulic lifting capacity of the machine.
- The strokes are as follows.
 - The load point corresponds to the front bolt part of the arm.
 - The machine positions are (i) over - front (Blade down), (ii) over - front (Blade up), and (iii) over - side.
 - The operating cylinder is the boom cylinder.
- The bucket of the excavator, the hook, the sling and other lifting accessories are taken into consideration for the loads.
Machine conditions:
No bucket, all others according to the standard regulations.



WARNING

To avoid personal injury or death:

- No loads greater than those values mentioned in the lifting capacity tables are to be lifted.
- The values mentioned in the table are valid only on even, hard grounds. When lifting on soft ground, the machine can tip over due to the load being concentrated only on one side of the machine.
- The table values are calculated at the end of the arm without the bucket. In order to find the allowable loads for machines with bucket, the bucket weight must be subtracted from the values in the table.
- Never lift the machine with the angle blade placed at an angle.

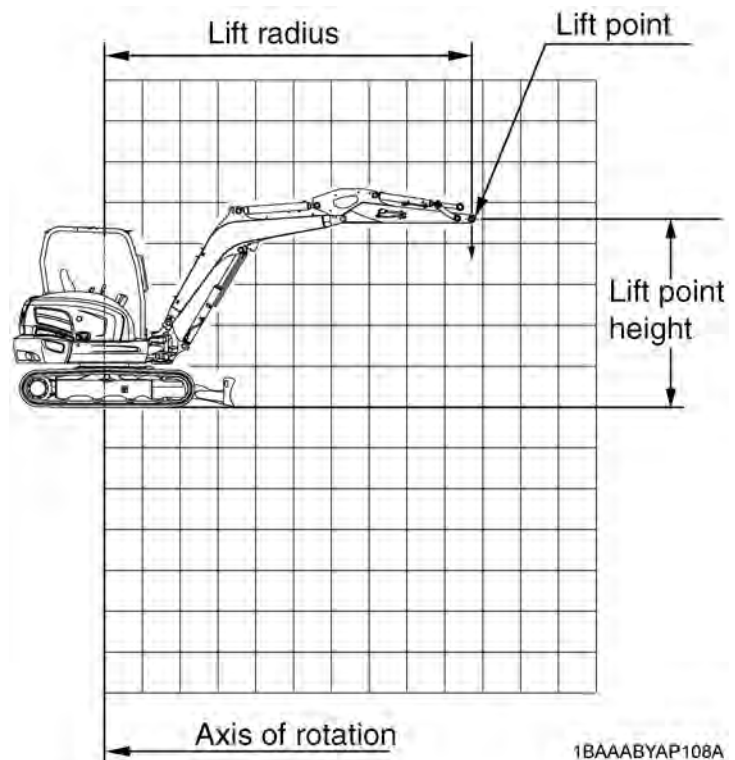

KX057-4 STANDARD ARM RUBBER TRACK CANOPY

LIFT POINT HEIGHT (m)	LIFT POINT RADIUS (m)										kN (kg)
	0.5	1.0	1.5	2.0	2.5	3.0	3.5	4.0	4.5	5.0	
4.0								9.9 (1010)			
3.5								9.9 (1010)	8.7 (880)		
3.0						10.5 (1070)	10.3 (1050)	8.6 (860)	7.2 (730)		
2.5						11.8 (1200)	10.3 (1060)	8.5 (870)	7.2 (730)		
2.0				19.0 (1930)	15.4 (1570)	12.5 (1280)	10.1 (1030)	8.4 (860)	7.1 (720)		
1.5				21.0 (2150)	15.5 (1580)	12.1 (1240)	9.9 (1010)	8.2 (840)	7.0 (710)		
1.0				20.1 (2050)	15.0 (1530)	11.8 (1200)	9.6 (980)	8.1 (820)	6.9 (700)		
0.5				19.8 (2000)	14.5 (1480)	11.5 (1170)	9.4 (960)	7.9 (810)	6.8 (690)		
0				15.4 (1570)	14.3 (1460)	11.3 (1150)	9.3 (950)	7.8 (800)	6.7 (680)		
-0.5		15.7 (1600)	16.4 (1670)	21.2 (2160)	19.2 (1960)	14.1 (1440)	11.2 (1140)	9.2 (940)	7.7 (790)	6.7 (680)	
-1.0		20.4 (2090)	22.3 (2270)	27.7 (2830)	19.2 (1960)	14.1 (1440)	11.1 (1130)	9.1 (930)	7.7 (790)		
-1.5		25.8 (2630)	28.8 (2940)	30.1 (3070)	19.3 (1970)	14.1 (1440)	11.1 (1140)	9.2 (930)	7.8 (790)		
-2.0		32.0 (3260)	36.6 (3730)	27.9 (2840)	19.5 (1990)	14.3 (1460)	11.2 (1150)	9.3 (950)			
-2.5		27.8 (2830)	20.5 (2090)	16.4 (1670)	13.1 (1340)						

OVER-FRONT (BLADE UP)

LIFT POINT HEIGHT (m)	LIFT POINT RADIUS (m)										kN (kg)
	0.5	1.0	1.5	2.0	2.5	3.0	3.5	4.0	4.5	5.0	
4.0								9.9 (1010)			
3.5								9.9 (1010)	10.0 (1020)		
3.0						10.5 (1070)	10.3 (1050)	10.2 (1040)	9.5 (970)		
2.5						11.8 (1200)	11.1 (1130)	10.6 (1080)	10.2 (1050)		
2.0				19.0 (1930)	15.4 (1570)	13.4 (1360)	12.0 (1230)	11.2 (1140)	10.5 (1070)		
1.5				24.3 (2480)	18.3 (1860)	15.1 (1540)	13.1 (1340)	11.8 (1210)	10.9 (1110)		
1.0				28.4 (2890)	20.7 (2120)	16.6 (1700)	14.1 (1440)	12.4 (1270)	11.2 (1150)		
0.5				25.2 (2570)	22.3 (2280)	17.8 (1810)	14.9 (1520)	12.9 (1320)	11.5 (1170)		
0				15.4 (1570)	27.3 (2790)	23.0 (2360)	18.4 (1880)	15.3 (1570)	13.2 (1340)	11.5 (1170)	
-0.5		15.7 (1600)	16.4 (1670)	21.2 (2160)	29.5 (3010)	23.0 (2330)	18.4 (1870)	15.4 (1570)	13.1 (1330)	11.1 (1130)	
-1.0		20.4 (2090)	22.3 (2270)	27.7 (2830)	27.8 (2840)	21.9 (2240)	17.8 (1820)	14.9 (1520)	12.5 (1270)		
-1.5		25.8 (2630)	28.8 (2940)	33.2 (3390)	25.3 (2560)	20.2 (2060)	16.5 (1690)	13.7 (1390)	10.9 (1110)		
-2.0		32.0 (3260)	36.6 (3730)	27.9 (2840)	21.7 (2210)	17.5 (1790)	14.2 (1450)	11.2 (1140)			
-2.5		27.8 (2830)	20.5 (2090)	16.4 (1670)	13.1 (1340)						

OVER-FRONT (BLADE DOWN)

LIFT POINT HEIGHT (m)	LIFT POINT RADIUS (m)										kN (kg)
	0.5	1.0	1.5	2.0	2.5	3.0	3.5	4.0	4.5	5.0	
4.0								8.9 (910)			
3.5								8.9 (910)	7.3 (750)		
3.0						10.5 (1070)	10.3 (1050)	8.8 (900)	7.3 (740)	6.1 (620)	
2.5						10.7 (1100)	8.7 (890)	7.2 (740)	6.1 (620)		
2.0				17.7 (1810)	13.2 (1350)	10.4 (1060)	8.5 (870)	7.1 (720)	6.0 (610)		
1.5				16.7 (1710)	12.7 (1290)	10.1 (1030)	8.3 (840)	6.9 (710)	5.9 (600)		
1.0				15.9 (1620)	12.2 (1240)	9.7 (990)	8.0 (820)	6.8 (690)	5.8 (590)		
0.5				15.4 (1570)	11.8 (1200)	9.5 (970)	7.8 (800)	6.6 (680)	5.7 (580)		
0				15.4 (1570)	15.2 (1550)	11.5 (1180)	9.3 (950)	7.7 (790)	6.5 (660)	5.6 (570)	
-0.5		15.7 (1600)	16.4 (1670)	21.2 (2160)	15.1 (1540)	11.4 (1160)	9.2 (930)	7.6 (780)	6.5 (660)	5.6 (570)	
-1.0		20.4 (2090)	22.3 (2270)	22.2 (2260)	15.1 (1540)	11.4 (1160)	9.1 (930)	7.6 (770)	6.4 (660)		
-1.5		25.8 (2630)	28.8 (2940)	22.4 (2280)	15.2 (1550)	11.4 (1170)	9.1 (930)	7.6 (770)	6.5 (660)		
-2.0		32.0 (3260)	36.6 (3730)	22.6 (2310)	15.3 (1570)	11.5 (1180)	9.2 (940)	7.7 (790)			
-2.5		27.8 (2830)	20.5 (2090)	15.6 (1600)	11.8 (1200)						

OVER-SIDE

KX057-4 STANDARD ARM RUBBER TRACK CAB

LIFT POINT HEIGHT (m)	LIFT POINT RADIUS (m)										kN (kg)
	0.5	1.0	1.5	2.0	2.5	3.0	3.5	4.0	4.5	5.0	
4.0								9.9 (1010)			
3.5								9.9 (1010)	8.9 (910)		
3.0						10.5 (1070)	10.3 (1050)	8.9 (900)	7.4 (760)		
2.5						11.8 (1200)	10.6 (1080)	8.8 (890)	7.4 (750)		
2.0				19.0 (1930)	15.4 (1570)	12.9 (1310)	10.4 (1060)	8.6 (880)	7.3 (740)		
1.5				21.6 (2210)	16.0 (1630)	12.5 (1270)	10.2 (1040)	8.5 (870)	7.2 (730)		
1.0				20.7 (2110)	15.4 (1570)	12.1 (1240)	9.9 (1010)	8.3 (850)	7.1 (720)		
0.5				20.1 (2060)	15.0 (1530)	11.8 (1210)	9.7 (990)	8.2 (830)	7.0 (720)		
0				15.4 (1570)	19.9 (2030)	14.7 (1500)	11.6 (1190)	9.6 (980)	8.1 (820)	6.9 (710)	
-0.5		15.7 (1600)	16.4 (1670)	21.2 (2160)	19.8 (2020)	14.6 (1490)	11.5 (1170)	9.5 (970)	8.0 (820)	6.9 (700)	
-1.0		20.4 (2090)	22.3 (2270)	27.7 (2830)	19.8 (2020)	14.5 (1480)	11.5 (1170)	9.4 (960)	8.0 (810)		
-1.5		25.8 (2630)	28.8 (2940)	31.0 (3160)	19.9 (2030)	14.6 (1490)	11.5 (1170)	9.4 (960)	8.0 (820)		
-2.0		32.0 (3260)	36.6 (3730)	27.9 (2840)	20.1 (2050)	14.7 (1500)	11.6 (1180)	9.6 (980)			
-2.5			27.8 (2830)	20.5 (2090)	16.4 (1670)	13.1 (1340)					

OVER-FRONT (BLADE UP)

LIFT POINT HEIGHT (m)	LIFT POINT RADIUS (m)										kN (kg)
	0.5	1.0	1.5	2.0	2.5	3.0	3.5	4.0	4.5	5.0	
4.0								9.9 (1010)			
3.5								9.9 (1010)	10.0 (1020)		
3.0						10.5 (1070)	10.3 (1050)	10.3 (1040)	9.5 (970)		
2.5						11.8 (1200)	11.1 (1130)	10.6 (1080)	10.2 (1050)		
2.0				19.0 (1930)	15.4 (1570)	13.4 (1360)	12.0 (1230)	11.2 (1140)	10.5 (1070)		
1.5				24.3 (2480)	18.3 (1860)	15.1 (1540)	13.1 (1340)	11.8 (1210)	10.9 (1110)		
1.0				28.4 (2890)	20.7 (2120)	16.6 (1700)	14.1 (1440)	12.4 (1270)	11.2 (1150)		
0.5				25.2 (2570)	22.3 (2280)	17.8 (1810)	14.9 (1520)	12.9 (1320)	11.5 (1170)		
0				15.4 (1570)	27.3 (2790)	23.0 (2360)	18.4 (1880)	15.3 (1570)	13.2 (1340)	11.5 (1170)	
-0.5		15.7 (1600)	16.4 (1670)	21.2 (2160)	29.5 (3010)	22.9 (2330)	18.4 (1880)	15.4 (1570)	13.1 (1330)	11.1 (1130)	
-1.0		20.4 (2090)	22.3 (2270)	27.7 (2830)	27.8 (2840)	21.9 (2240)	17.8 (1820)	14.9 (1520)	12.5 (1270)		
-1.5		25.8 (2630)	28.8 (2940)	33.2 (3390)	25.3 (2580)	20.2 (2060)	16.5 (1690)	13.7 (1390)	10.9 (1110)		
-2.0		32.0 (3260)	36.6 (3730)	27.9 (2840)	21.7 (2210)	17.5 (1790)	14.2 (1450)	11.2 (1140)			
-2.5			27.8 (2830)	20.5 (2090)	16.4 (1670)	13.1 (1340)					

OVER-FRONT (BLADE DOWN)

LIFT POINT HEIGHT (m)	LIFT POINT RADIUS (m)										kN (kg)
	0.5	1.0	1.5	2.0	2.5	3.0	3.5	4.0	4.5	5.0	
4.0								9.2 (940)			
3.5								9.2 (940)	7.5 (770)		
3.0						10.5 (1070)	9.1 (930)	7.5 (770)	6.3 (640)		
2.5						11.0 (1120)	8.9 (910)	7.4 (760)	6.2 (640)		
2.0				18.2 (1860)	13.6 (1390)	10.7 (1090)	8.7 (890)	7.3 (740)	6.2 (630)		
1.5				17.2 (1750)	13.0 (1330)	10.4 (1060)	8.5 (870)	7.1 (730)	6.1 (620)		
1.0				16.3 (1670)	12.5 (1280)	10.0 (1020)	8.3 (840)	7.0 (710)	6.0 (610)		
0.5				15.8 (1620)	12.1 (1240)	9.8 (1000)	8.1 (830)	6.8 (700)	5.9 (600)		
0				15.4 (1570)	15.8 (1590)	11.9 (1210)	9.6 (980)	7.9 (810)	6.7 (690)	5.8 (590)	
-0.5		15.7 (1600)	16.4 (1670)	21.2 (2160)	15.5 (1580)	11.8 (1200)	9.4 (960)	7.8 (800)	6.7 (680)	5.8 (590)	
-1.0		20.4 (2090)	22.3 (2270)	22.8 (2330)	15.5 (1580)	11.7 (1200)	9.4 (960)	7.8 (800)	6.7 (680)		
-1.5		25.8 (2630)	28.8 (2940)	23.0 (2350)	15.6 (1590)	11.8 (1200)	9.4 (960)	7.8 (800)	6.7 (680)		
-2.0		32.0 (3260)	36.6 (3730)	23.3 (2380)	15.8 (1610)	11.9 (1210)	9.5 (970)	7.9 (810)			
-2.5			27.8 (2830)	20.5 (2090)	16.1 (1640)	12.1 (1240)					

OVER-SIDE

**KX057-4 STANDARD ARM
STEEL TRACK
CANOPY**

LIFT POINT HEIGHT (m)	LIFT POINT RADIUS (m)										kN (kg)
	0.5	1.0	1.5	2.0	2.5	3.0	3.5	4.0	4.5	5.0	
4.0								9.9 (1010)			
3.5								9.9 (1010)	9.2 (940)		
3.0							10.5 (1070)	10.3 (1050)	9.2 (940)	7.7 (780)	
2.5							11.8 (1200)	11.0 (1130)	9.1 (930)	7.7 (780)	
2.0							19.0 (1930)	15.4 (1570)	13.4 (1360)	10.8 (1100)	7.6 (770)
1.5							22.8 (2320)	16.7 (1700)	13.0 (1330)	10.6 (1080)	8.8 (900)
1.0							21.8 (2220)	16.1 (1640)	12.7 (1290)	10.3 (1050)	8.8 (880)
0.5							21.2 (2170)	15.7 (1600)	12.4 (1260)	10.1 (1030)	8.5 (870)
0							15.4 (1570)	21.0 (2140)	15.4 (1570)	12.2 (1240)	10.0 (1020)
-0.5							15.7 (1600)	16.4 (1670)	21.2 (2160)	15.3 (1560)	12.0 (1230)
-1.0							20.4 (2090)	22.3 (2270)	20.9 (2130)	15.2 (1560)	12.0 (1200)
-1.5							25.8 (2630)	28.8 (2940)	33.1 (3360)	21.0 (2140)	15.3 (1560)
-2.0							32.0 (3260)	36.6 (3730)	27.9 (2840)	21.2 (2160)	15.4 (1570)
-2.5							27.8 (2830)	20.5 (2090)	16.4 (1670)	13.1 (1340)	

LIFT POINT HEIGHT (m)

OVER-FRONT (BLADE UP)

LIFT POINT HEIGHT (m)	LIFT POINT RADIUS (m)										kN (kg)
	0.5	1.0	1.5	2.0	2.5	3.0	3.5	4.0	4.5	5.0	
4.0								9.9 (1010)			
3.5								9.9 (1010)	10.0 (1020)		
3.0							10.5 (1070)	10.3 (1050)	10.2 (1040)	9.5 (970)	
2.5							11.8 (1200)	11.1 (1130)	10.6 (1080)	10.2 (1050)	
2.0							19.0 (1930)	15.4 (1570)	13.4 (1360)	12.0 (1230)	11.2 (1140)
1.5							24.3 (2480)	18.3 (1860)	15.1 (1540)	13.1 (1340)	11.8 (1210)
1.0							28.4 (2890)	20.7 (2120)	16.6 (1700)	14.1 (1440)	12.4 (1270)
0.5							25.2 (2570)	22.3 (2280)	17.8 (1810)	14.9 (1520)	12.9 (1320)
0							15.4 (1570)	27.3 (2790)	23.0 (2360)	18.4 (1880)	15.3 (1570)
-0.5							15.7 (1600)	16.4 (1670)	21.2 (2160)	15.4 (1570)	13.1 (1340)
-1.0							20.4 (2090)	22.3 (2270)	27.7 (2830)	21.9 (2240)	17.8 (1820)
-1.5							25.8 (2630)	28.8 (2940)	33.2 (3390)	25.3 (2580)	20.2 (2060)
-2.0							32.0 (3260)	36.6 (3730)	27.9 (2840)	21.7 (2210)	17.5 (1790)
-2.5							27.8 (2830)	20.5 (2090)	16.4 (1670)	13.1 (1340)	

LIFT POINT HEIGHT (m)

OVER-FRONT (BLADE DOWN)

LIFT POINT HEIGHT (m)	LIFT POINT RADIUS (m)										kN (kg)
	0.5	1.0	1.5	2.0	2.5	3.0	3.5	4.0	4.5	5.0	
4.0								9.1 (930)			
3.5								9.1 (930)	7.5 (760)		
3.0							10.5 (1070)	9.0 (920)	7.5 (760)	6.2 (630)	
2.5							10.9 (1120)	8.9 (900)	7.4 (750)	6.2 (630)	
2.0							18.1 (1840)	13.5 (1380)	8.7 (880)	7.2 (740)	6.1 (620)
1.5							17.1 (1740)	12.9 (1320)	10.3 (1050)	8.4 (860)	7.1 (720)
1.0							16.2 (1650)	12.4 (1270)	10.0 (1020)	8.2 (840)	6.9 (710)
0.5							15.7 (1600)	12.0 (1230)	9.7 (990)	8.0 (820)	6.8 (690)
0							15.4 (1570)	15.5 (1580)	11.8 (1200)	9.5 (970)	7.9 (800)
-0.5							15.7 (1600)	16.4 (1670)	21.2 (2160)	15.4 (1570)	11.7 (1190)
-1.0							20.4 (2090)	22.3 (2270)	23.7 (2310)	15.4 (1580)	11.6 (1190)
-1.5							25.8 (2630)	28.8 (2940)	22.9 (2330)	15.5 (1580)	11.7 (1190)
-2.0							32.0 (3260)	36.6 (3730)	23.1 (2360)	15.7 (1600)	11.8 (1200)
-2.5							27.8 (2830)	20.5 (2090)	16.0 (1630)	12.0 (1230)	

LIFT POINT HEIGHT (m)

OVER-SIDE

KX057-4 STANDARD ARM
STEEL TRACK
CAB

LIFT POINT HEIGHT (m)	LIFT POINT RADIUS (m)										kN (kg)
	0.5	1.0	1.5	2.0	2.5	3.0	3.5	4.0	4.5	5.0	
4.0								9.9 (1010)			
3.5								9.9 (1010)	9.5 (970)		
3.0						10.5 (1070)	10.3 (1050)	10.3 (1050)	9.5 (970)	7.9 (810)	
2.5						11.8 (1200)	11.1 (1130)	11.1 (1130)	9.4 (960)	7.9 (810)	
2.0					19.0 (1930)	15.4 (1570)	13.4 (1360)	11.1 (1130)	9.2 (940)	7.8 (800)	
1.5					23.4 (2390)	17.1 (1750)	13.4 (1370)	10.9 (1110)	9.1 (920)	7.7 (790)	
1.0					22.4 (2290)	16.6 (1690)	13.0 (1330)	10.6 (1080)	8.9 (910)	7.6 (780)	
0.5					21.9 (2230)	16.1 (1650)	12.7 (1300)	10.4 (1060)	8.8 (890)	7.5 (770)	
0					15.4 (1570)	21.6 (2200)	15.9 (1620)	12.5 (1280)	10.3 (1050)	8.7 (880)	7.4 (760)
-0.5		15.7 (1600)	16.4 (1670)	21.2 (2160)	21.5 (2190)	15.7 (1610)	12.4 (1260)	10.2 (1040)	8.6 (880)	7.4 (760)	
-1.0		20.4 (2090)	22.3 (2270)	27.7 (2830)	21.5 (2190)	15.7 (1600)	12.3 (1260)	10.1 (1030)	8.6 (870)		
-1.5		25.8 (2630)	28.8 (2940)	33.2 (3390)	25.3 (2580)	20.2 (2060)	15.7 (1610)	12.4 (1260)	10.1 (1030)	8.6 (880)	
-2.0		32.0 (3260)	36.6 (3730)	27.9 (2840)	21.7 (2210)	17.5 (1790)	15.9 (1620)	12.5 (1270)	10.3 (1050)		
-2.5		27.8 (2830)	20.5 (2090)	16.4 (1670)	13.1 (1340)						

OVER-FRONT (BLADE UP)

LIFT POINT HEIGHT (m)	LIFT POINT RADIUS (m)										kN (kg)
	0.5	1.0	1.5	2.0	2.5	3.0	3.5	4.0	4.5	5.0	
4.0								9.9 (1010)			
3.5								9.9 (1010)	10.0 (1020)		
3.0						10.5 (1070)	10.3 (1050)	10.3 (1050)	10.2 (1040)	9.5 (970)	
2.5						11.8 (1200)	11.1 (1130)	11.1 (1130)	10.6 (1080)	10.2 (1040)	
2.0					19.0 (1930)	15.4 (1570)	13.4 (1360)	12.0 (1230)	11.2 (1140)	10.5 (1070)	
1.5					24.3 (2480)	18.3 (1860)	15.1 (1540)	13.1 (1340)	11.8 (1210)	10.9 (1110)	
1.0					28.4 (2890)	20.7 (2120)	16.6 (1700)	14.1 (1440)	12.4 (1270)	11.2 (1150)	
0.5					25.2 (2570)	22.3 (2280)	17.8 (1810)	14.9 (1520)	12.9 (1320)	11.5 (1170)	
0					15.4 (1570)	27.3 (2790)	23.0 (2350)	18.4 (1880)	15.3 (1570)	13.2 (1340)	11.5 (1170)
-0.5		15.7 (1600)	16.4 (1670)	21.2 (2160)	21.5 (2190)	15.7 (1610)	12.4 (1260)	10.2 (1040)	8.6 (880)	7.4 (760)	
-1.0		20.4 (2090)	22.3 (2270)	27.7 (2830)	21.5 (2190)	15.7 (1600)	12.3 (1260)	10.1 (1030)	8.6 (870)		
-1.5		25.8 (2630)	28.8 (2940)	33.2 (3390)	25.3 (2580)	20.2 (2060)	15.7 (1610)	12.4 (1260)	10.1 (1030)	8.6 (880)	
-2.0		32.0 (3260)	36.6 (3730)	27.9 (2840)	21.7 (2210)	17.5 (1790)	15.9 (1620)	12.5 (1270)	10.3 (1050)		
-2.5		27.8 (2830)	20.5 (2090)	16.4 (1670)	13.1 (1340)						

OVER-FRONT (BLADE DOWN)

LIFT POINT HEIGHT (m)	LIFT POINT RADIUS (m)										kN (kg)
	0.5	1.0	1.5	2.0	2.5	3.0	3.5	4.0	4.5	5.0	
4.0								9.4 (960)			
3.5								9.4 (950)	7.7 (780)		
3.0						10.5 (1070)	10.3 (1040)	10.3 (1040)	9.3 (940)	6.4 (650)	
2.5						11.2 (1150)	9.1 (930)	9.1 (930)	7.6 (770)	6.4 (650)	
2.0					18.5 (1890)	13.8 (1410)	10.9 (1110)	8.9 (910)	7.4 (760)	6.3 (640)	
1.5					17.5 (1790)	13.3 (1360)	10.6 (1080)	8.7 (890)	7.3 (740)	6.4 (630)	
1.0					16.7 (1700)	12.8 (1300)	10.2 (1040)	8.5 (860)	7.1 (730)	6.1 (620)	
0.5					16.2 (1650)	12.4 (1260)	10.0 (1020)	8.3 (840)	7.0 (710)	6.0 (610)	
0					15.4 (1570)	21.2 (2160)	15.9 (1620)	12.2 (1230)	9.8 (1000)	8.1 (830)	6.0 (610)
-0.5		15.7 (1600)	16.4 (1670)	21.2 (2160)	21.5 (2190)	15.7 (1610)	12.0 (1230)	9.6 (980)	8.0 (820)	5.9 (600)	
-1.0		20.4 (2090)	22.3 (2270)	27.7 (2830)	21.5 (2190)	15.7 (1600)	12.0 (1220)	9.6 (980)	8.0 (810)	5.8 (590)	
-1.5		25.8 (2630)	28.8 (2940)	33.2 (3400)	23.5 (2400)	16.0 (1630)	12.0 (1230)	9.6 (980)	8.0 (820)	5.9 (600)	
-2.0		32.0 (3260)	36.6 (3730)	27.9 (2840)	21.7 (2210)	17.5 (1790)	16.1 (1650)	12.2 (1240)	9.7 (990)	8.1 (830)	
-2.5		27.8 (2830)	20.5 (2090)	16.4 (1670)	12.4 (1260)						

OVER-SIDE

U55-4 STANDARD ARM RUBBER TRACK CANOPY

LIFT POINT HEIGHT (3)	LIFT POINT RADIUS (m)										kN (kg)	
	0.5	1.0	1.5	2.0	2.5	3.0	3.5	4.0	4.5	5.0		5.5
4.0							9.4 (960)					
3.5						11.2 (1140)	9.4 (960)	7.7 (780)				
3.0						11.6 (1190)	9.3 (950)	7.6 (780)				
2.5						14.7 (1500)	11.4 (1160)	9.1 (930)	7.6 (770)	6.3 (650)		
2.0					19.1 (1950)	14.1 (1440)	11.0 (1120)	8.9 (910)	7.4 (760)	6.3 (640)		
1.5						13.4 (1370)	10.6 (1080)	8.7 (890)	7.3 (740)	6.2 (630)		
1.0						12.9 (1320)	10.3 (1050)	8.5 (860)	7.1 (730)	6.1 (620)		
0.5						12.6 (1280)	10.0 (1020)	8.3 (840)	7.0 (710)	6.0 (610)		
0						16.7 (1700)	12.4 (1260)	9.9 (1010)	8.1 (830)	6.9 (700)	6.0 (610)	
-0.5					18.1 (1850)	21.8 (2230)	16.7 (1700)	12.3 (1260)	9.8 (1000)	8.1 (820)	6.8 (700)	
-1.0					24.2 (2470)	25.1 (2570)	19.7 (2040)	12.3 (1260)	9.8 (1000)	8.1 (820)	6.9 (700)	
-1.5					30.3 (3100)	33.0 (3360)	26.2 (2670)	16.9 (1730)	12.4 (1270)	9.8 (1000)	8.1 (830)	
-2.0					34.6 (3530)	25.0 (2550)	17.2 (1750)	12.6 (1290)	10.0 (1020)			
-2.5					15.8 (1610)	13.3 (1360)	10.5 (1070)					

OVER-FRONT (BLADE UP)

LIFT POINT HEIGHT (3)	LIFT POINT RADIUS (m)										kN (kg)	
	0.5	1.0	1.5	2.0	2.5	3.0	3.5	4.0	4.5	5.0		5.5
4.0							11.3 (1160)					
3.5							11.2 (1140)	11.1 (1140)	11.2 (1150)			
3.0							12.0 (1230)	11.5 (1180)	11.2 (1150)			
2.5							14.9 (1520)	13.3 (1360)	12.3 (1250)	11.6 (1180)	11.2 (1140)	
2.0						23.3 (2380)	17.8 (1820)	15.0 (1530)	13.3 (1360)	12.2 (1240)	11.4 (1160)	
1.5						20.8 (2120)	16.7 (1710)	14.4 (1460)	12.8 (1310)	11.7 (1190)		
1.0						23.1 (2360)	18.2 (1860)	15.3 (1560)	13.4 (1360)	12.0 (1220)		
0.5						24.2 (2470)	19.2 (1960)	15.9 (1630)	13.7 (1400)	12.1 (1230)		
0						24.6 (2510)	24.4 (2490)	19.5 (1990)	16.2 (1650)	13.8 (1410)	11.9 (1210)	
-0.5					18.1 (1850)	21.8 (2230)	30.1 (3070)	23.7 (2420)	19.2 (1960)	16.0 (1630)	13.5 (1380)	
-1.0					24.2 (2470)	25.1 (2570)	30.0 (3060)	27.8 (2840)	22.2 (2270)	18.2 (1860)	15.1 (1540)	12.5 (1270)
-1.5					30.3 (3100)	33.0 (3360)	31.4 (3200)	24.6 (2510)	20.0 (2040)	16.4 (1670)	13.4 (1370)	
-2.0					34.6 (3530)	25.0 (2550)	20.1 (2060)	16.5 (1680)	13.3 (1360)			
-2.5					15.8 (1610)	13.3 (1360)	10.5 (1070)					

OVER-FRONT (BLADE DOWN)

LIFT POINT HEIGHT (3)	LIFT POINT RADIUS (m)										kN (kg)	
	0.5	1.0	1.5	2.0	2.5	3.0	3.5	4.0	4.5	5.0		5.5
4.0							7.9 (800)					
3.5							9.8 (1000)	7.9 (800)	6.4 (650)			
3.0							9.7 (980)	7.8 (790)	6.4 (650)			
2.5							12.0 (1220)	9.4 (960)	7.6 (780)	6.3 (640)	5.3 (540)	
2.0						15.1 (1540)	11.4 (1170)	9.1 (920)	7.4 (760)	6.2 (630)	5.2 (530)	
1.5							10.9 (1110)	8.7 (890)	7.2 (730)	6.0 (620)	5.1 (520)	
1.0							10.4 (1050)	8.4 (860)	7.0 (710)	5.9 (600)	5.1 (520)	
0.5							10.1 (1030)	8.1 (830)	6.8 (690)	5.8 (590)	5.0 (510)	
0							12.9 (1320)	9.9 (1010)	8.0 (810)	6.7 (680)	5.7 (580)	4.9 (500)
-0.5					18.1 (1850)	19.0 (1940)	12.9 (1320)	9.8 (1000)	7.9 (810)	6.6 (670)	5.6 (580)	
-1.0					24.2 (2470)	25.1 (2570)	13.0 (1330)	9.8 (1000)	7.9 (810)	6.6 (670)	5.7 (580)	
-1.5					30.3 (3100)	33.0 (3360)	13.1 (1340)	9.9 (1010)	8.0 (810)	6.6 (680)		
-2.0					34.6 (3530)	19.7 (2010)	13.4 (1370)	10.1 (1030)	8.1 (830)			
-2.5					15.8 (1610)	13.3 (1360)	10.4 (1070)					

OVER-SIDE

U55-4 STANDARD ARM RUBBER TRACK CAB

LIFT POINT HEIGHT (m)	LIFT POINT RADIUS (m)										kN (kg)
	0.5	1.0	1.5	2.0	2.5	3.0	3.5	4.0	4.5	5.0	
4.0								9.7 (950)			
3.5							11.2 (1140)	9.7 (950)	7.9 (800)		
3.0						12.0 (1220)	9.6 (960)	7.9 (800)			
2.5					14.9 (1520)	11.7 (1190)	9.4 (960)	7.8 (790)	6.5 (660)		
2.0				19.6 (2000)	14.5 (1480)	11.3 (1160)	9.2 (940)	7.7 (780)	6.5 (660)		
1.5						13.9 (1410)	11.0 (1120)	9.0 (910)	7.5 (760)	6.4 (650)	
1.0						13.3 (1360)	10.6 (1080)	8.7 (890)	7.3 (750)	6.3 (640)	
0.5						13.0 (1320)	10.3 (1050)	8.5 (870)	7.2 (740)	6.2 (630)	
0						17.2 (1750)	12.8 (1300)	10.2 (1040)	8.4 (860)	7.1 (730)	6.2 (630)
-0.5			18.1 (1850)	21.8 (2230)	17.2 (1750)	12.7 (1300)	10.1 (1030)	8.3 (850)	7.1 (720)		
-1.0			24.2 (2470)	25.1 (2570)	17.3 (1760)	12.7 (1300)	10.1 (1030)	8.3 (850)	7.1 (720)		
-1.5			30.3 (3100)	33.0 (3360)	27.0 (2750)	17.4 (1780)	12.8 (1310)	10.1 (1030)	8.4 (860)		
-2.0			34.5 (3520)	25.0 (2550)	17.7 (1800)	13.0 (1330)	10.3 (1050)				
-2.5				15.8 (1610)	13.3 (1360)	10.5 (1070)					

OVER-FRONT (BLADE UP)

LIFT POINT HEIGHT (m)	LIFT POINT RADIUS (m)										kN (kg)
	0.5	1.0	1.5	2.0	2.5	3.0	3.5	4.0	4.5	5.0	
4.0								11.3 (1160)			
3.5							11.2 (1140)	11.1 (1140)	11.2 (1150)		
3.0						12.0 (1230)	11.5 (1180)	11.2 (1150)			
2.5					14.9 (1520)	13.3 (1360)	12.3 (1250)	11.6 (1180)	11.2 (1140)		
2.0				23.3 (2360)	17.8 (1820)	15.0 (1530)	13.3 (1360)	12.2 (1240)	11.4 (1160)		
1.5					20.8 (2120)	16.7 (1710)	14.3 (1460)	12.8 (1300)	11.7 (1190)		
1.0					23.1 (2350)	18.2 (1860)	15.3 (1560)	13.4 (1360)	12.0 (1220)		
0.5					24.2 (2470)	19.2 (1950)	15.9 (1630)	13.7 (1400)	12.1 (1230)		
0					24.6 (2510)	19.5 (1990)	16.2 (1650)	13.8 (1410)	12.0 (1210)		
-0.5			18.1 (1850)	21.8 (2230)	30.1 (3070)	23.7 (2410)	19.2 (1960)	16.0 (1630)	13.5 (1360)		
-1.0			24.2 (2470)	25.1 (2570)	30.0 (3060)	27.8 (2830)	22.2 (2270)	18.2 (1860)	15.1 (1540)	12.5 (1270)	
-1.5			30.3 (3100)	33.0 (3360)	31.4 (3200)	24.6 (2510)	19.9 (2040)	16.4 (1670)	13.4 (1370)		
-2.0			34.5 (3520)	25.0 (2550)	20.1 (2050)	16.5 (1680)	13.3 (1350)				
-2.5				15.8 (1610)	13.3 (1360)	10.5 (1070)					

OVER-FRONT (BLADE DOWN)

LIFT POINT HEIGHT (m)	LIFT POINT RADIUS (m)										kN (kg)
	0.5	1.0	1.5	2.0	2.5	3.0	3.5	4.0	4.5	5.0	
4.0								8.1 (820)			
3.5							10.1 (1030)	8.1 (820)	6.6 (670)		
3.0						9.9 (1010)	8.0 (820)	6.6 (670)			
2.5					12.3 (1260)	9.7 (990)	7.8 (800)	6.5 (660)	5.6 (560)		
2.0				15.5 (1580)	11.8 (1200)	9.3 (950)	7.6 (780)	6.4 (650)	5.4 (550)		
1.5					11.2 (1140)	9.0 (910)	7.4 (750)	6.2 (630)	5.3 (540)		
1.0					10.7 (1090)	8.6 (880)	7.2 (730)	6.1 (620)	5.2 (530)		
0.5					10.4 (1060)	8.4 (860)	7.0 (710)	6.0 (610)	5.1 (520)		
0					13.3 (1360)	10.2 (1040)	8.2 (840)	6.9 (700)	5.9 (600)	5.1 (520)	
-0.5			18.1 (1850)	19.6 (2000)	13.3 (1360)	10.1 (1030)	8.2 (830)	6.8 (690)	5.8 (590)		
-1.0			24.2 (2470)	25.1 (2570)	19.7 (2010)	13.4 (1370)	10.1 (1030)	8.1 (820)	6.8 (690)	5.8 (600)	
-1.5			30.3 (3100)	33.0 (3360)	33.0 (3360)	19.9 (2030)	13.6 (1380)	10.2 (1040)	8.2 (840)	6.9 (700)	
-2.0			34.5 (3520)	20.2 (2070)	13.8 (1410)	10.4 (1060)	8.4 (850)				
-2.5				15.8 (1610)	13.3 (1360)	10.5 (1070)					

OVER-SIDE

U55-4 STANDARD ARM
STEEL TRACK
CANOPY

LIFT POINT HEIGHT (m)	LIFT POINT RADIUS (m)										kN (kg)	
	0.5	1.0	1.5	2.0	2.5	3.0	3.5	4.0	4.5	5.0		5.5
4.0								9.6 (960)				
3.5							11.1 (1130)	9.6 (960)	7.8 (800)			
3.0							11.9 (1210)	9.5 (970)	7.8 (800)			
2.5							14.8 (1510)	11.6 (1190)	9.4 (960)	7.7 (790)	6.5 (660)	
2.0					19.6 (2000)	14.4 (1470)	11.3 (1150)	9.1 (930)	7.6 (780)	6.4 (660)		
1.5						13.8 (1410)	10.9 (1110)	8.9 (910)	7.5 (760)	6.3 (650)		
1.0						13.3 (1350)	10.6 (1080)	8.7 (890)	7.3 (750)	6.2 (640)		
0.5						12.9 (1320)	10.3 (1050)	8.5 (870)	7.2 (730)	6.2 (630)		
0						17.2 (1750)	12.7 (1300)	10.1 (1030)	8.4 (860)	7.1 (720)	6.0 (620)	
-0.5			17.9 (1820)	21.6 (2200)	17.2 (1750)	12.7 (1290)	10.0 (1020)	8.3 (850)	7.0 (720)			
-1.0			23.9 (2440)	29.7 (2540)	27.5 (2800)	22.0 (2240)	18.0 (1840)	15.0 (1530)	12.3 (1260)			
-1.5			30.0 (3060)	32.6 (3330)	31.0 (3160)	24.3 (2480)	19.7 (2010)	16.2 (1660)	13.2 (1350)			
-2.0			34.2 (3490)	24.7 (2520)	19.9 (2030)	16.3 (1660)	13.1 (1340)					
-2.5			15.6 (1590)	13.2 (1340)	10.3 (1060)							

OVER-FRONT (BLADE UP)

LIFT POINT HEIGHT (m)	LIFT POINT RADIUS (m)										kN (kg)	
	0.5	1.0	1.5	2.0	2.5	3.0	3.5	4.0	4.5	5.0		5.5
4.0								11.2 (1140)				
3.5							11.1 (1130)	11.0 (1120)	11.1 (1130)			
3.0							11.9 (1210)	11.4 (1160)	11.1 (1130)			
2.5							14.8 (1510)	13.2 (1350)	12.2 (1240)	11.5 (1170)	11.1 (1130)	
2.0					23.0 (2350)	17.6 (1800)	14.8 (1510)	13.1 (1340)	12.0 (1230)	11.3 (1150)		
1.5						20.6 (2100)	16.6 (1690)	14.2 (1450)	12.6 (1290)	11.6 (1180)		
1.0						22.8 (2330)	18.0 (1840)	15.1 (1540)	13.2 (1350)	11.8 (1210)		
0.5						24.0 (2440)	18.9 (1930)	15.8 (1610)	13.6 (1390)	11.9 (1220)		
0						24.3 (2480)	21.1 (2160)	19.3 (1970)	16.0 (1630)	13.7 (1400)	11.8 (1200)	
-0.5			17.9 (1820)	21.6 (2200)	29.8 (3040)	23.4 (2390)	19.0 (1940)	15.8 (1610)	13.3 (1360)			
-1.0			23.9 (2440)	29.7 (2540)	27.5 (2800)	22.0 (2240)	18.0 (1840)	15.0 (1530)	12.3 (1260)			
-1.5			30.0 (3060)	32.6 (3330)	31.0 (3160)	24.3 (2480)	19.7 (2010)	16.2 (1660)	13.2 (1350)			
-2.0			34.2 (3490)	24.7 (2520)	19.9 (2030)	16.3 (1660)	13.1 (1340)					
-2.5			15.6 (1590)	13.2 (1340)	10.3 (1060)							

OVER-FRONT (BLADE DOWN)

LIFT POINT HEIGHT (m)	LIFT POINT RADIUS (m)										kN (kg)	
	0.5	1.0	1.5	2.0	2.5	3.0	3.5	4.0	4.5	5.0		5.5
4.0								7.9 (810)				
3.5							9.9 (1010)	7.9 (810)	6.5 (660)			
3.0							9.7 (990)	7.9 (800)	6.5 (660)			
2.5							12.1 (1230)	9.5 (970)	7.7 (790)	6.4 (660)	5.4 (560)	
2.0					15.3 (1560)	11.6 (1180)	9.2 (930)	7.5 (760)	6.3 (640)	5.3 (540)		
1.5						11.0 (1120)	8.8 (900)	7.3 (740)	6.1 (620)	5.2 (530)		
1.0						10.5 (1070)	8.5 (870)	7.1 (720)	6.0 (610)	5.1 (520)		
0.5						10.2 (1040)	8.3 (840)	6.9 (700)	5.9 (600)	5.1 (520)		
0						13.1 (1340)	10.0 (1020)	8.1 (830)	6.8 (690)	5.8 (590)	5.0 (510)	
-0.5			17.9 (1820)	19.3 (1970)	13.1 (1340)	10.0 (1020)	8.0 (820)	6.7 (680)	5.7 (580)			
-1.0			23.9 (2440)	24.9 (2540)	19.4 (1980)	13.2 (1350)	10.0 (1020)	8.0 (820)	6.7 (680)	5.7 (590)		
-1.5			30.0 (3060)	32.6 (3330)	19.6 (2000)	13.3 (1360)	10.1 (1030)	8.1 (820)	6.7 (690)			
-2.0			34.2 (3490)	19.9 (2030)	13.6 (1380)	10.2 (1040)	8.2 (840)					
-2.5			15.6 (1590)	13.2 (1340)	10.3 (1060)							

OVER-SIDE

U55-4 STANDARD ARM
STEEL TRACK
CAB

LIFT POINT HEIGHT (m)	LIFT POINT RADIUS (m)										kN (kg)
	0.5	1.0	1.5	2.0	2.5	3.0	3.5	4.0	4.5	5.0	
4.0							10.0 (1020)				
3.5						11.2 (1140)	10.0 (1020)	8.2 (830)			
3.0					12.0 (1230)	9.9 (1010)	8.1 (830)				
2.5				14.9 (1520)	12.1 (1230)	9.7 (990)	8.1 (820)	6.8 (690)			
2.0			20.4 (2080)	15.0 (1530)	11.7 (1200)	9.5 (970)	7.9 (810)	6.7 (680)			
1.5				14.4 (1460)	11.3 (1160)	9.3 (950)	7.8 (790)	6.6 (670)			
1.0				13.8 (1410)	11.0 (1120)	9.0 (920)	7.6 (780)	6.5 (660)			
0.5				13.5 (1370)	10.7 (1090)	8.9 (900)	7.5 (760)	6.4 (660)			
0				17.9 (1830)	13.3 (1360)	10.6 (1080)	8.7 (890)	7.4 (750)	6.4 (640)		
-0.5		18.1 (1850)	21.8 (2230)	17.9 (1830)	13.2 (1350)	10.5 (1070)	8.6 (880)	7.3 (750)			
-1.0		24.2 (2470)	25.1 (2570)	27.9 (2840)	18.0 (1830)	13.2 (1350)	10.5 (1070)	8.6 (880)	7.4 (750)		
-1.5		30.3 (3100)	33.0 (3360)	28.1 (2870)	18.1 (1850)	13.3 (1360)	10.5 (1070)	8.7 (890)			
-2.0		34.5 (3520)	25.0 (2550)	18.4 (1880)	13.5 (1380)	10.7 (1090)					
-2.5		15.8 (1610)	13.3 (1360)	10.5 (1070)							

OVER-FRONT (BLADE UP)

LIFT POINT HEIGHT (m)	LIFT POINT RADIUS (m)										kN (kg)
	0.5	1.0	1.5	2.0	2.5	3.0	3.5	4.0	4.5	5.0	
4.0								11.3 (1160)			
3.5						11.2 (1140)	11.1 (1140)	11.2 (1150)			
3.0					12.0 (1230)	11.5 (1180)	11.2 (1150)				
2.5				14.9 (1520)	13.3 (1360)	12.3 (1250)	11.6 (1180)	11.2 (1140)			
2.0			23.3 (2380)	17.8 (1820)	15.0 (1530)	13.3 (1360)	12.2 (1240)	11.4 (1160)			
1.5				20.8 (2120)	16.7 (1710)	14.4 (1460)	12.8 (1300)	11.7 (1190)			
1.0				23.1 (2350)	18.2 (1860)	15.3 (1560)	13.4 (1360)	12.0 (1220)			
0.5				24.2 (2470)	19.1 (1950)	15.9 (1630)	13.7 (1400)	12.1 (1230)			
0				24.6 (2510)	19.5 (1990)	16.2 (1650)	13.8 (1410)	11.9 (1210)			
-0.5		18.1 (1850)	21.8 (2230)	30.1 (3070)	23.7 (2410)	19.2 (1960)	16.0 (1630)	13.5 (1380)			
-1.0		24.2 (2470)	25.1 (2570)	30.0 (3060)	27.8 (2820)	22.2 (2260)	18.2 (1860)	15.1 (1540)	12.5 (1270)		
-1.5		30.3 (3100)	33.0 (3360)	31.3 (3200)	24.6 (2510)	19.9 (2040)	16.4 (1670)	13.4 (1370)			
-2.0		34.5 (3520)	25.0 (2550)	20.1 (2050)	16.4 (1680)	13.3 (1350)					
-2.5		15.8 (1610)	13.3 (1360)	10.5 (1070)							



OVER-FRONT (BLADE DOWN)

LIFT POINT HEIGHT (m)	LIFT POINT RADIUS (m)										kN (kg)
	0.5	1.0	1.5	2.0	2.5	3.0	3.5	4.0	4.5	5.0	
4.0								8.2 (840)			
3.5						10.3 (1050)	8.3 (840)	6.7 (680)			
3.0					10.1 (1030)	8.2 (830)	6.7 (680)				
2.5				12.6 (1280)	9.9 (1010)	8.0 (820)	6.6 (680)	5.6 (570)			
2.0			15.9 (1620)	12.0 (1220)	9.5 (970)	7.8 (800)	6.5 (670)	5.5 (560)			
1.5				11.4 (1170)	9.2 (940)	7.6 (770)	6.4 (650)	5.4 (550)			
1.0				10.9 (1120)	8.8 (900)	7.4 (750)	6.2 (640)	5.3 (550)			
0.5				10.6 (1080)	8.6 (880)	7.2 (730)	6.1 (620)	5.3 (540)			
0				13.7 (1390)	10.4 (1070)	8.4 (860)	7.0 (710)	6.0 (610)	5.2 (530)		
-0.5		18.1 (1850)	20.1 (2050)	13.7 (1390)	10.4 (1060)	8.4 (860)	7.0 (710)	6.0 (610)			
-1.0		24.2 (2470)	25.1 (2570)	20.21 (2060)	13.7 (1400)	10.4 (1070)	8.3 (850)	7.0 (710)	6.0 (610)		
-1.5		30.3 (3100)	33.0 (3360)	20.4 (2080)	13.9 (1420)	10.5 (1070)	8.4 (860)	7.0 (720)			
-2.0		34.5 (3520)	20.7 (2110)	14.1 (1440)	10.7 (1090)	8.6 (870)					
-2.5		15.8 (1610)	13.3 (1360)	10.5 (1070)							

OVER-SIDE

LIST OF SCREENS

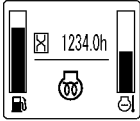
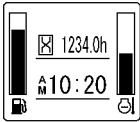
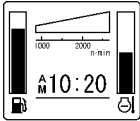
LIST OF NORMAL SCREENS

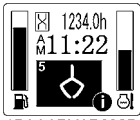
No.	Message	Problem or failure (What happened)	Machine behavior (Provisional measure)	Correction
1	Glow screen  1BAABBLAP248B	This screen indicates that the glow lamp is on.	Wait until the glow mark disappears. Then get the engine started.	-
2	Default screen (normal)  1BAABBLAP249B	This screen shows the normal status. (Hour meter)	-	-
3	Default screen (normal) Tachometer (graph)  1BAABBLAP250B	This screen shows the normal status. (Tachometer)	-	-
4	Default screen (normal) Tachometer (numeric)  1BAABBLAP251B	This screen shows the normal status. (Numerical display of tachometer readings)	-	-
5	AUX port enable switch activated  1BAAABYAP030B	AUX port enable screen	-	-







NAVIGATION LIST OF SCREENS



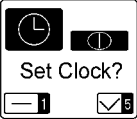

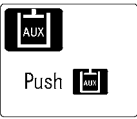

If an error occurs with the machine, one of the following messages appears in the LCD display.







In case of trouble, immediately contact your local dealer for inspection and repair.





While the (i) (information mark) appears onscreen, press the information switch, and detailed information will be displayed.

Notify your local dealer of this and other information.

No.	Message	Problem or failure (What happened)	Machine behavior (Provisional measure)	Correction
1	Clock setting request  1BAABBLAP255B	The battery is disconnected, thereby requiring to set the clock.	Press Switch 5 to set the clock.	-
2	Tilt up the lock lever.  1BAABBLAP142B	This message indicates a procedural step.	Tilt up the pilot control lock lever. This message disappears by tilting up the pilot control lock lever.	-
3	Tilt down the lock lever.  1BAABBLAP257B	This message indicates a procedural step.	Tilt down the pilot control lock lever. This message disappears by tilting down the pilot control lock lever.	-
4	Start the engine.  1BAABBLAP258B	This message indicates a procedural step.	Start the engine. This message then disappears.	-
5	Press Switch 3.  1BAAABYAP031A	This message appears if the AUX function is tried without pressing the AUX port enable switch.	Press the AUX port enable switch.	-
6	Not equipped with AUX2/Thumb function  1BAAABYAP032A	The AUX2 port is tried on machines not equipped with AUX2 function.	-	-

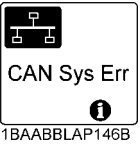
No.	Message	Problem or failure (What happened)	Machine behavior (Provisional measure)	Correction
7	<p>Not equipped with overload warning function</p>  <p>Not Overload Spec.</p> <p>1BAABYAP036A</p>	<p>This message appears if the overload warning switch is pressed on machines not equipped with overload warning system.</p>	-	-
8	<p>Out of fuel</p>  <p>Feed fuel</p> <p>1BAABBLAP215B</p>	<p>Fuel is running out.</p>	-	Add fuel.
9	<p>Fuel sensor error</p>  <p>Fuel Sensor Err</p> <p>1BAABBLAP139B</p>	<p>The fuel sensor system is in trouble.</p>	<p>The fuel level indicator does not appear on the meter. Press the display selector switch, and the normal display is switched back. The machine's other functions are still operative.</p>	<p>Immediately contact your local dealer.</p>
10	<p>Charging system error</p>  <p>Charging Sys Err</p> <p>1BAABBLAP136B</p>	<p>Charging system is in trouble. The battery is not charging.</p>	<p>The machine works until the battery goes dead.</p>	<p>Immediately contact your local dealer.</p>
11	<p>Engine oil pressure error</p>  <p>Engine Oil Press Err Stop Engine</p> <p>1BAABBLAP137B</p>	<p>The engine lubricating system oil pressure is too low. Stop the engine.</p>	<p>The engine may get burnt out. Immediately stop the engine.</p>	<p>Immediately contact your local dealer.</p>
12	<p>Overvoltage</p>  <p>Over voltage Sys Err</p> <p>1BAABBLAP138B</p>	<p>This message appears if a jumper cable is connected to a 24V battery or improper device to get the engine started or if the alternator is in trouble.</p>	<p>Immediately interrupt the engine if with a 24V battery. When the engine gets restarted and is running with no message appearing, it means there is no problem.</p>	<p>If this message still appears, immediately ask for repair.</p>
13	<p>Overheat advance warning Water temperature rising</p>  <p>Water temp is Rising</p> <p>1BAABBLAP140B</p>	<p>Water temperature is rising somewhat higher than specified.</p>	<p>Operate with the load a little lessened. Check the radiator and other components for clog. Immediately clean them up.</p>	-

No.	Message	Problem or failure (What happened)	Machine behavior (Provisional measure)	Correction
14	Cool-down during overheat idling  1BAABBLAP141B	The engine automatically reduces rpm's avoid an overheat.	Leave the engine idling until this warning disappears. Do not stop the engine because the coolant temperature will increase sharply and may boil and gush out. Be sure to cool down the engine without stopping it.	Refill the radiator with coolant by its boiled-over amount. Unclog the radiator and other components before use again. Check also the hydraulic system for oil leak and other troubles. If an oil leak is found, immediately contact your local dealer for repair.
15	Water temperature sensor error  1BAABBLAP237B	Water temperature sensor error system is in trouble.	The meter does not show water temperature. Press the display selector switch, and the normal display is switched back. The machine's other functions are operative, but an overheat and other problems cannot be detected.	Immediately contact your local dealer.
16	Lock lever system error  1BAABBLAP244B	The lock lever system is in trouble.	The engine can run, but the machine fails to move.	Immediately contact your local dealer.
17	Travel 2-speed system (switching)  1BAABBLAP147B	The 2-speed switching system is in trouble.	The machine still runs at low speed without switching to high speed. The machine's other functions are still operative.	Immediately contact your local dealer.
18	AI system error  1BAABBLAP273B	The Auto Idle system is in trouble. The accelerator fails too.	The accelerator fails, but the machine's other functions are still operative. Move the machine to a place suited for repair.	Immediately contact your local dealer.
19	5V short-circuit  1BAABBLAP152B	The sensor's 5V power supply is short-circuited.	The majority of systems fail. * The engine may get started and the machine may move. But do not try any jobs. (Just move the machine to a safe place.)	Immediately contact your local dealer.

No.	Message	Problem or failure (What happened)	Machine behavior (Provisional measure)	Correction
20	<p>12V short-circuit</p>  <p>1BAABBLAP239B</p>	The sensor's or switch's 12V line is short-circuited.	The majority of systems fail. * The engine may start and the machine may move. But do not try any jobs. (Just move the machine to a safe place.)	Immediately contact your local dealer.
21	<p>CAN system error</p>  <p>1BAABBLAP146B</p>	The communication (CAN) system is in trouble. Some meter readings may be erroneous or some switches may malfunction.	The engine may get started and the machine may move. But do not try any jobs. (Just move the machine to a safe place.)	Immediately contact your local dealer.
22	<p>General switching system error</p>  <p>1BAAABYAP035B</p>	The general switching system is in trouble. (This message appears only when the general switching function is preset effective.)	The engine can get restarted and the machine can move, but the general switching system fails. When the other systems than the general switching system function, the job can be continued.	Immediately contact your local dealer.
23	<p>AUX1 port system error</p>  <p>1BAAABYAP035A</p>	The AUX1 port system is in trouble.	The engine can get restarted and the machine can move, but the AUX1 port system fails. When the other systems than the AUX1 port system function, the job can be continued.	Immediately contact your local dealer.
24	<p>Periodic check (advance notice)</p>  <p>1BAABBLAP265B</p>	This message appears 10 hours before the periodic check interval. Press the information switch, and the list of related components can be reviewed.	Get the engine started as usual.	Ask your local dealer for relevant part and replace the existing part with it. After replacement, turn on and off the key 10 times, and this message disappears.
25	<p>Periodic check (warning)</p>  <p>1BAABBLAP266B</p>	The periodic check interval has passed. Press the information switch, and the list of related components can be reviewed.	The engine can still get started, but immediately ask your local dealer for replacement.	Ask your local dealer for relevant part and replace the existing part with it. After replacement, turn on and off the key 10 times, and this message disappears.