

series 60

Minitransporter



Ed. 1



USER'S MANUAL AND MAINTENANCE



This manual should always be readily available so that the machine operator may consult it immediately, and it must be saved for the entire duration of the machine's life.

© 2010 - The entire or partial reproduction and/or divulging of this document is prohibited in any form without the written consent of the manufacturing company. The editing of the text, the illustrations, and the paginations were realized by "Cormidi s.r.l." The information and technical data were furnished, checked and validated by the Cormidi Technical Office. The illustrations and technical data included in this manual are non binding: **the manufacturer reserves the right to carry out eventual modifications to its product without notice.**

CORMIDI
leadinginnovation

CORMIDI srl

Via Fonte, 342

84069 Roccadaspide (SA)

☎ 0828 943689 Fax 0828 943963

💻 www.cormidi.com info@cormidi.com

INTRODUCTION

Dear Customer,

We would like to take this opportunity to thank you for your confidence in us shown by purchasing a CORMIDI Minitransporter. This product was designed and constructed for longevity and to be used with maximum reliability.

*It is, however, **absolutely necessary** to read this manual carefully in which the procedure for optimum use of the equipment is described: improper use may provoke harm to oneself and cause injury to persons and/or to one's health.*

*Therefore, always keep this manual within easy reach so that it may be consulted at any time, before, during, and after use. If the machine is resold, do not forget to give it to the new owner in that inside there is the **EC compliance certificate**.*

We would like to remind you that the illustrations contained in the manual correspond for the most part

to the base model and that our models are regularly improved and perfected with the goal of allowing our customers to enjoy the maximum benefits of innovations in technology: for this reason the characteristics and the information contained in the present manual may have been varied recently. We ask you to contact us in case you should encounter difficulty.

Remember for supplementary information you can always contact your sales representative/dealer, or you can contact us directly by telephone or by email at info@cormidi.com. If there is any doubt, it is better to ask rather than proceed on your own.

We leave you to your perusal of the manual and enjoyment of your machine!

Staff CORMIDI Srl

1. GENERAL INFORMATION

1.1. WARRANTY

Your machine is guaranteed for 12 months from the date of its delivery and includes the substitution of anything in particular that has resulted as, in the opinion of our Technical Office, affected by construction defects.

Any part in particular that was not constructed by the manufacturer, parts used in/on terrain surfaces, and breakdowns caused by incompetence or carelessness, including fuelling, are excluded from the guarantee.

The motor, instead, is covered under the manufacturer of the motor's own warranty according to the foreseen conditions and terms.

The guarantee immediately expires if the machine is utilized for uses different from those foreseen by the Manufacturer, if it is damaged by the use of unauthorized accessories or if it is repaired using unsuitable parts.

With the machine a Certificate of Warranty was supplied which outlines the norms which regulate the service of assistance under warranty. We highly recommend reading the **warranty form** to fully

understand the various rights and responsibilities. Collaborate with your sales representative when filling out the form and make sure it is filled out correctly, in that the text and the other formalities (shipment within the time limit, etc.) represent the legal base for the warranty on the machine.

1.2. GOAL OF THE MANUAL

This manual has been drawn up by the manufacturer and is an integral part of the machine: it was written in Italian, the native language of the manufacturer (1.7.4 - 2006/42/CE).

The information contained here within is addressed to expert operators, equipped with specific knowledge and competence in the sector of use. The manual defines the objectives for which the machine was designed and constructed.

To avoid incorrect manoeuvres that risk accident, it is important to read this manual particularly before the first use to familiarize oneself with the principal commands and their functions.

A constant observance of the information

guarantees safety, economy of use, and a longer functional duration of the machine.

To give a higher prominence to the sections of the text which must not be ignored, they have been highlighted in bold and preceded with symbols illustrated and defined following here:



READ CAREFULLY: economy of use, and a longer functional duration of the machine.



DANGER: indicates imminently dangerous situations that can provoke serious injury or death if the instructions are not followed.

On the machine potential dangers have been indicated with a sticker characterized by a *red band with white text*.



WARNING: indicates a potentially dangerous situation that can provoke serious injury or death if the instructions are not followed.

On the machine the warnings are indicated with stickers characterized by an *orange band with black text*.



CAUTION: indicates a potentially dangerous situation that can provoke injury or damage to the machine if the instructions are not followed.

On the machine situations requiring caution are indicated by stickers characterized by a *yellow band with black text*.



PROHIBITED: prohibitions that must be observed by all persons who interact directly and/or indirectly with the machine so that risks may be limited.

1.3. MACHINE DESCRIPTION

The Series 60 machines are compact auto-unloading tracked vehicles that are equipped with a body, designed and manufactured for the exclusive use of transporting inert materials.

To satisfy the various requirements of the market, the machine may be equipped with motors that have similar power but that have different brand names and characteristics.



READ CAREFULLY: Determine the type of motor that has been installed in your machine accurately, and read its manual to familiarize yourself with it.

1.4. SAFETY INFORMATION



READ CAREFULLY: The information contained here is essential for your safety and for that of your co-workers!

During the production of this machine, every possible measure was taken to make your work safer. Simple prudence, however, is essential: there is no better rule to prevent accidents.



WARNING: The tool must always be operated by a competent and well-trained operator.

- ☞ Carefully read the information before using the machine or before performing maintenance and/or repairs.
- ☞ A few minutes of your time spent reading this manual will save you time and effort later on.
- ☞ Carefully read the warnings and information written on the signs on the machine and immediately

substitute missing or illegible ones. **Respect all regulations contained in these.**

- ☞ The machine was made exclusively for the transportation of inert materials. Any other use is prohibited.



PROHIBITED: It is strictly prohibited to use this machine for the transport of persons and/or animals.



PROHIBITED: It is strictly prohibited to use this machine to tow other machines, vehicles, and/or devices, not even temporarily or in an emergency situation.

- ☞ The machine constitutes a work instrument: always respect the national regulations, especially those relative to safety at the place of work.



REQUIRED: Always wear suitable work clothes and above all suitable work shoes diligently. Always use protective hearing devices.



WARNING: Never wear large or fly-away clothes (scarves, ties, or other) that could easily get caught in the moving parts.

☞ It is always advisable to have a first aid kit close at hand.

☞ Before turning on the motor, always be sure that there are not any people, animals, or things that could be an obstacle in the work area.



DANGER: Never use the machine inside enclosed areas because the gasses emitted by the exhaust are lethal.



REQUIRED: Carry out the disposal of oils, minerals, and harmful products with respect for the environment and in accordance with the current norms.

☞ **Every intervention** for cleaning, tuning, and/or maintenance must be done under good environmental conditions and with adequate light, and **always with the engine turned off.**



DANGER: Never refuel the vehicle when the motor is on or hot, in the proximity of flames or while smoking. Always keep the machine cleaned of lubricant and/or combustible residues.

☞ Pay careful attention to not come into contact with the overheated parts of the motor.



PROHIBITED: It is strictly prohibited to remove protection and safety devices with which the machine is equipped

☞ Avoid working under unsuitable physical conditions or when you are very tired: in these cases interrupt your work.



DANGER: While working always be sure that the terrain has the required consistency and avoid working on the edge of embankments, ditches, or ravines or on excessively steep or uneven terrain.

☞ When putting away the machine take all precautions so that it might not be moved or turned on by incompetent or incapable persons.





CAUTION: Never leave the machine unattended while the motor is on, not even temporarily: when you leave the area, turn off the motor of the machine and put on the parking brake!



DANGER: Never let children play with the machine, not even if it is turned off!

1.5. MACHINE AND MANUFACTURER IDENTIFICATION

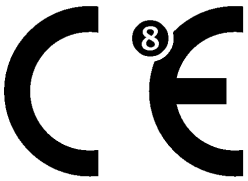
The data which identifies the machine and the manufacturer are listed on the aluminium plate that is affixed on the dashboard of the machine. The frame number is stamped on the front left side (*see fig. 1*).

Modello	2	<input type="text"/>	 <p>CORMIDI srl <small>Via Seude - Loc. Fonte 84069 ROCCADASPIDE (SA) ITALY 0828 943 689 Fax 0828 943 963 www.cormidi.com info@cormidi.com</small></p>	
Matricola	3	<input type="text"/>		
Portata Kg	4	<input type="text"/>		
Massa Kg	5	<input type="text"/>		
kW	6	<input type="text"/>		
Anno	7	<input type="text"/>		
C1094.14.00				

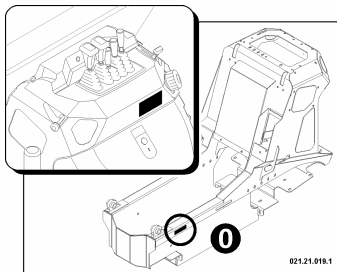



fig. 1 – Identification Plate (cod. C1094.14.00)

1	<i>Manufacturer</i>
2	<i>Machine Type</i>
3	<i>Serial Numero</i>
4	<i>Load Capacity KG</i>
5	<i>Machine Mass KG</i>
6	<i>Motor Power KW</i>
7	<i>Fabrication Year</i>
8	<i>EC Brand</i>
0	<i>Frame Number</i>

1.6. SAFETY DEVICES

 **PROHIBITED:** it is strictly prohibited to use the machine with its safety devices and protection removed, blocked, or in any way made non functional.

 **WARNING:** Before beginning work, verify the working order of the safety devices and substitute any worn-out and/or broken parts immediately.

1.6.1. BLOCKING THE BODY

The machine is equipped with a device to block the body in the raised position and to prevent it from lowering accidentally.

Before carrying out any repair maintenance work with the body raised, always block the piston following this procedure (*see fig. 2*):

- raise the body;
- turn off the motor;
- remove device “A” from its slot, down on the right side of the body, by unscrewing wheel “B”;
- insert the shaped side of the bar on the piston of the hydraulic jack;

- Turn the bar and position it so that it is parallel to the piston;
- slowly lower the unit **with the engine off**, until the correct fit of the device is obtained.

Afterwards remove the device and put it back in its slot on the frame.

1.6.2. BLOCKING THE FOOTREST

The drive footrest must always be blocked in open position, during the work, to prevent its accidental movement, by using the safety pin spring "C" (*see fig.2*).

- ☞ **To lower the platform**, pull out the ring of the plug spring "C" and lower the platform by releasing the ring, when you push the platform it will automatically lock in the down position;
- ☞ **To raise the platform**, pull out the ring of the plug spring "C" and raise the platform by releasing the ring, when you raise the platform it will automatically lock in raised position.



CAUTION: Always use the drive footrest in open position during the work, to prevent risks. Close the drive footrest only after use.

1.6.3. BLOCKING THE LIFT ("HI-TIP")

The raising device for the body for high unloading (Hi-Tip) can be blocked in a raised position to impede accidental movement.

Before carrying out any repair maintenance work with the Hi-Tip raised, always block the piston following this procedure (*see fig. 2*):

- Raise the Hi-Tip;
- Turn off the engine;
- Remove the safety device "D", by unscrewing wheel "B";
- insert the shaped side of the bar on the piston of the hydraulic jack;
- Turn the bar and position it so that it is parallel to the piston;
- slowly lower the unit **with the engine off**, until the correct fit of the device is obtained.

Afterwards remove the device and put it back in its slot on the frame.

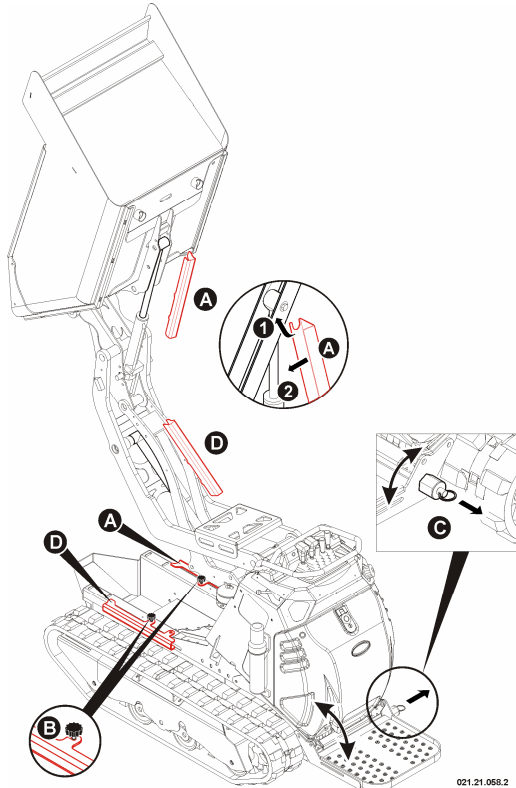

fig. 2 – Safety Devices

1.7. ACCESSORIES



READ CAREFULLY: Read the instructions and the mode of use for the accessories that have been installed on your machine carefully. Refer to the instruction manual that was provided with them.

The machine is furnished with equipment to make it possible to carry out normal maintenance operations.

1.8. SAFETY TAGS

READ CAREFULLY: During the design phase everything possible was done to prevent eventual risks: where it was technically impossible, specific pictograms were resorted to in order to highlight eventual potential and imminent risks.



Specific adhesive tags were made with signals and descriptions associated with pictograms to give a higher importance to possible dangers, in accordance with government norms UNI 9244-95 (E).



PROHIBITED: it is strictly prohibited to remove the stickers and the safety plates which the machine is equipped with: immediately substitute deteriorated and/or illegible ones.

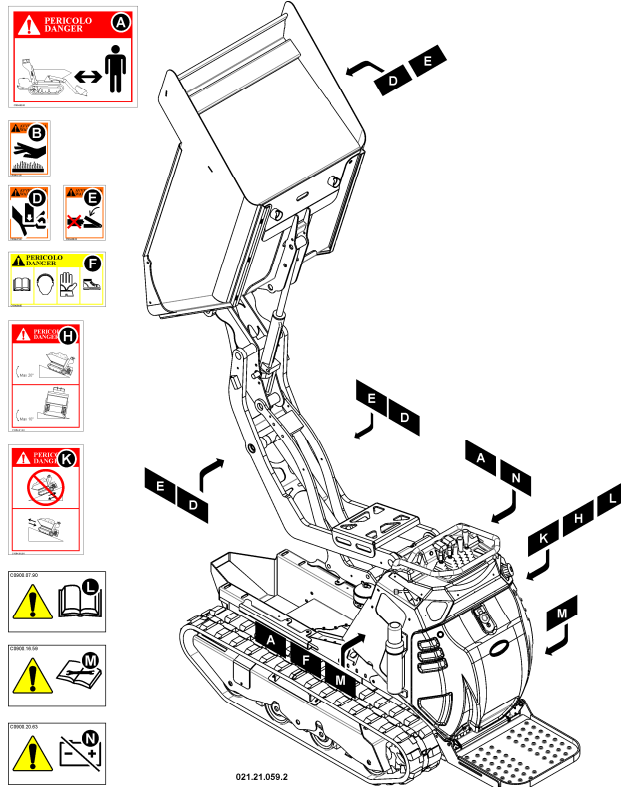

fig. 3 – Position of the SafetyTags

1.8.1. SAFETY DISTANCE

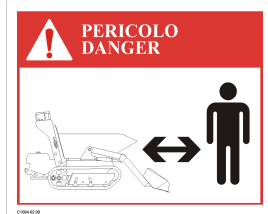

fig. 4 (cod. C1094.02.00)

Tag which alerts the serious danger of coming near and standing within the field of action of the machine in that there is an imminent risk of danger.

1.8.2. HOT SURFACE

Invites caution in that there is a risk of burning because of the nearness to the hot surface.



fig. 5 (cod. C1094.07.00)

1.8.3. FAN

Indicates a potential risk of danger in that there is a possibility of coming into contact with moving mechanical parts that can cause serious injury.



fig. 6 (cod. C1094.08.00)

1.8.4. CRUSHING

Tags which indicate a potential risk of crushing that may cause very serious injury or death.



fig. 7 (cod. C1094.09.00)

1.8.5. CUTTING

Tags which indicate a potential risk of cutting that may cause very serious injury or death.



fig. 8 (cod. C1094.09.00)

1.8.6. PROCEDURE FOR CAUTION

This adhesive which invites caution reminds one to adopt all anti-injury precautions, above all regarding the use of protective devices and individual prevention. The meaning of the pictograms is the following:

- Read the manual before turning the machine on for the first time, each time an operator is changed, and in any case in which doubt is raised as to how the machine

functions;

- Wear a headset which protects hearing or another device of this type;
- Wear protective gloves of the prescribed type;
- Wear safety shoes of the prescribed type.



fig. 9 (cod. C1094.04.00)

1.8.8. PROCEDURE FOR ADDRESSING SLOPES

Sign which indicates in what way one must address the downhill and uphill slopes to avoid serious consequences for the operator and for the machine in that there is the potential danger of overturning.



fig. 11 (cod. C1094.06.00)

1.8.7. MAXIMUM SLOPES

Completely avoid working on terrains that have latitudinal slopes of more than 10° and longitudinal slopes of more than 20° to avoid the possibility of overturning with serious consequences for the safety of the operator. In every case, but especially in the case of slopes, it is important that the terrain is solid and stable.

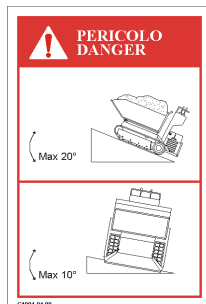

fig. 10 (cod. C1094.01.00)

1.8.9. OTHER TAGS

The label on the side (fig. 12-a) indicates that it is necessary to read the documentation before any intervention, to avoid technical problems (ex. Manual attached to the engine).

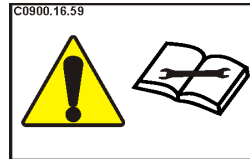

fig. 12-a (cod. C0900.16.59)

The label on the side (fig. 12-b) indicates that you should read the owner's manual before using the devices next to this label, to avoid problems.

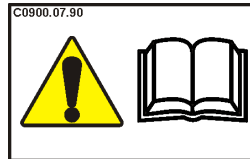

fig. 12-b (cod. C0900.07.90)

The label on the side (fig. 12-c) indicate the possibility of disconnection of the battery from the electrical circuit of the machine; near the label you can find the **cut off battery** device (see cap. 2).



fig. 12-c (cod. C0900.20.63)

ADMISSIBLE SLOPES

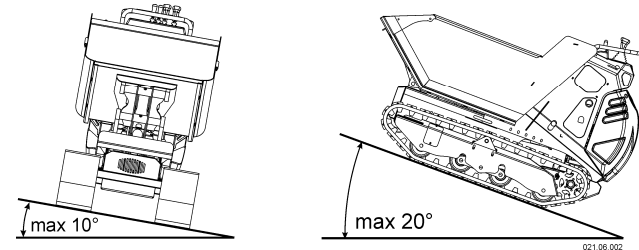

fig. 13 – Maximum admissible slopes

In figure 13 the maximum values for the latitudinal and longitudinal slopes of the terrain are shown on which it is possible to work.

These conditions must never be surpassed to avoid the risk of overturning.



DANGER: Always avoid working on terrain with slopes that are greater than those prescribed to avoid the possibility of overturning with possible serious consequences for the safety of the operator.

In every case, but especially when working on slopes, it is important that the ground is solid and plain.

1.9. DIMENSIONS

		Normal	Hi-Tip
Length		1820 mm	1820 mm
Width		695 mm	695 mm
Height to pivot		445 mm	1675 mm
Height	Min	115 mm	115 mm
	Max	1155 mm	1155 mm

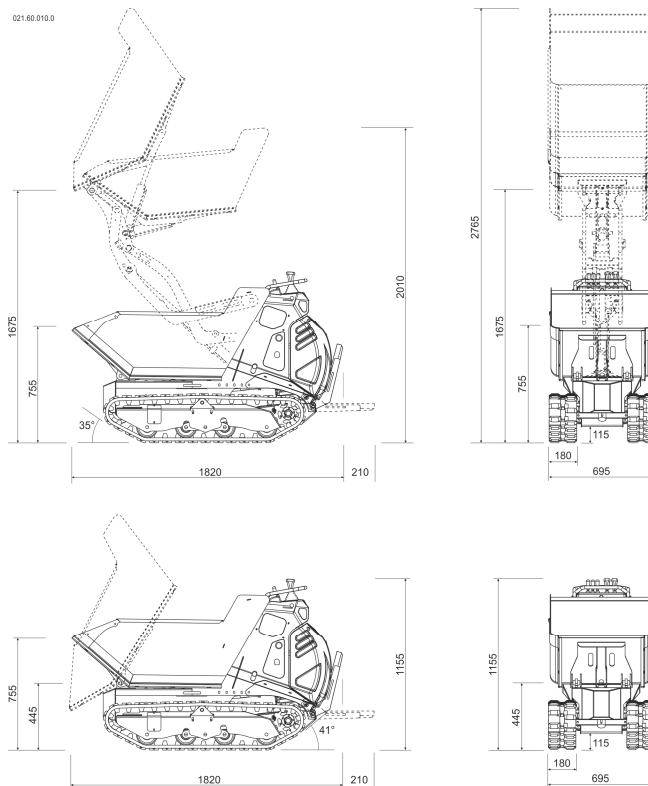

fig. 14 – Dimensions

1.10. TECHNICAL DATA

Model	Dumper		Hi-Tip
Type	6.60		6.60
Mass [kg]	415		535
Engine	diesel		diesel
Power [kW] - (cv)	4,9 (6,7)		4,9 (6,7)
Max Speed [km/h] - (m/s)	3,6 (1,2)		3,6 (1,2)
Load Capacity [kg]	600		
Start-up	Electric		
Accelerator	Manual command lever		
Transmission	Hydrostatic		
Parking Brake	Mechanical		
Battery	12V - 45Ah with negative at mass		
	Tipo	6.60	6.60
Continuous Equivalent Pondered Acoustic Power Level A	LpA =	100 dB(A)	100 dB(A)
Continuous Equivalent Pondered Acoustic Power Level A (assured)	LwA =	101 dB(A)	101 dB(A)
Vibrations Level	m/s²	on arms: $\leq 2,5 \text{ m/s}^2$ on body: $\leq 1,1 \text{ m/s}^2$	

2. COMMANDS

2.1. HYDRAULIC OVERTURNING VERSION

Parking Brake Command

The parking brake command, **which also serves as an emergency brake**, allows you to insert or deactivate the brake.

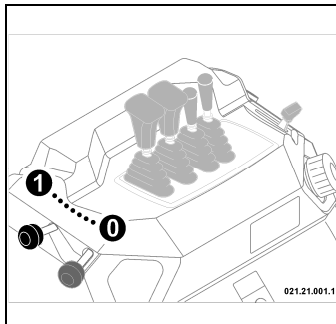

0	STABLE POSITION Deactivated Brake
1	STABLE POSIZIONE Activated Brake
<p><i>fig. 15</i> <i>Command lever for the parking brake</i></p>	

Accelerator Command

Allows you to vary the motor rotation regimen, so that you may obtain the required power.

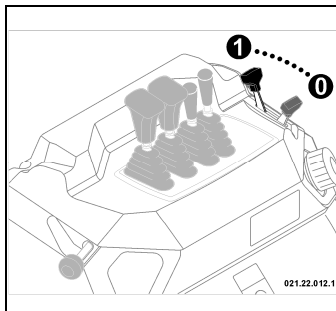

0	STABLE POSITION Minimum regimen
...	STABLE POSITION Intermediate regimens
1	STABLE POSITION Maximum regimen
<p><i>fig. 16</i> <i>Accelerator Command</i></p>	

Drive Levers

The command levers control the rotation of the tracks through a hydraulic feed of the hydraulic motors. The command levers are active only when the motor is turned on.

The left Drive Lever

The left-hand drive lever controls the left track.

	2 UNSTABLE POSITION The left track rotates forward
	0 STABLE POSITION Resting position
	1 UNSTABLE POSITION The left track rotates backwards
<i>fig. 17</i> <i>Command lever for the left track</i>	

The right Drive Lever

The right-hand drive lever controls the right track.

	2 UNSTABLE POSITION The right track rotates forward
	0 STABLE POSITION Resting position
	1 UNSTABLE POSITION The right track rotates backwards
<i>fig. 18</i> <i>Command lever for the right track</i>	

Command Lever for the Body

The command lever for the body activates the hydraulic jack that activates the tipping of the body.

This position ② can only be used with the motor turned on, while this position ① can also be used when the engine is turned off.

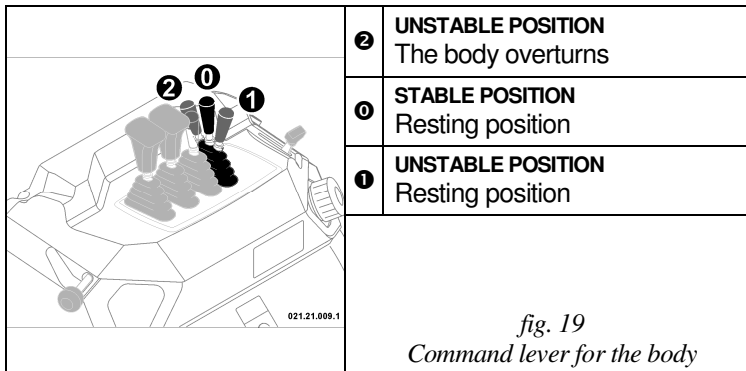

Command Lever for the Speed

The command lever for the speed operate on the traction hydraulic circuit, to increase the speed of traslation of the machine.

The position ① (Fast) must be used only for long journey.

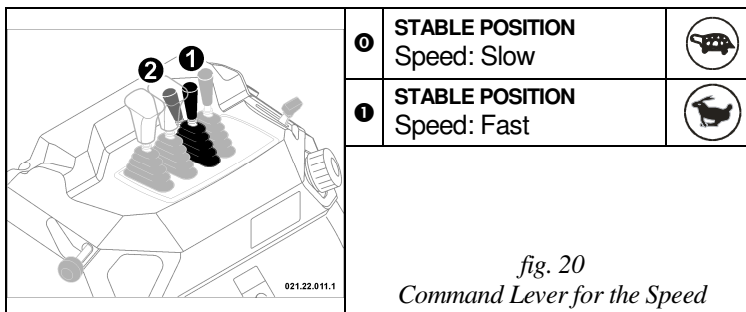

Horn Command

The horn button is on the left side of the instrument panel. To sound the horn, push the button. Only intermittent mode horn operation is enabled. Continuous mode is not enabled.

The command works only with the engine running.

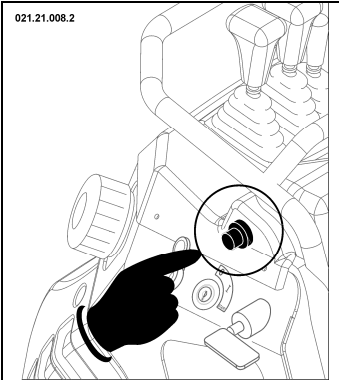
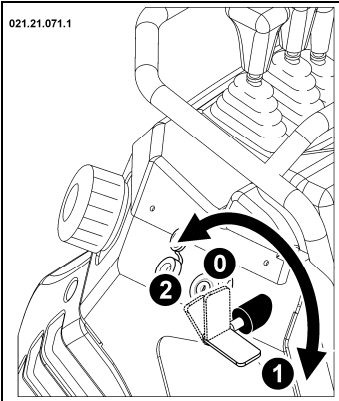

fig. 21
Horn Command

Cut Off Battery Command

The device lever on the left side of the dashboard controls the disconnection of the battery from the electrical circuit of the machine.

Use the cut off battery to disconnect power from the electrical circuit, particularly if the machine stop to work, for a long period of time, can be removed the lever to prevent the discharge of the battery.



1	STABLE POSITION Battery connected
0	STABLE POSITION Battery unplugged
2	STABLE POSITION Battery unplugged, it's possible remove the lever

fig. 22
Cut Off Battery Command

2.1.1. IGNITION CONTROL

The ignition control is on the right side of the dashboard, easily accessible by the operator.

To use the ignition control, is required a dedicated key provided.

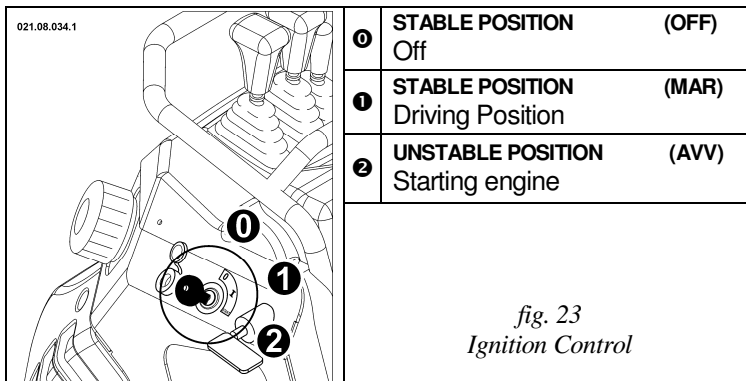

2.2. “HI-TIP” VERSION

Parking Brake Command

The command for the parking break, **which also serves as an emergency brake**, allows one to activate or deactivate the brake.

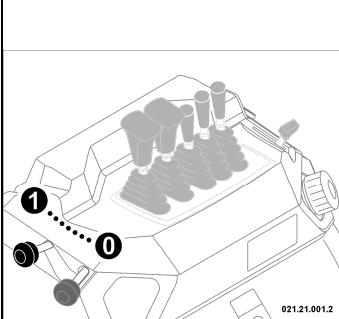
 <p>021.21.001.2</p>	<p>0 STABLE POSITION Deactivated brake</p>
	<p>1 STABLE POSITION Activated brake</p>
	<p><i>fig. 24</i> <i>Command lever for the parking brake</i></p>

Accelerator Command

The command lever of the accelerator acts upon the motor and allows one to vary the rotation regimen in order to obtain the required power.

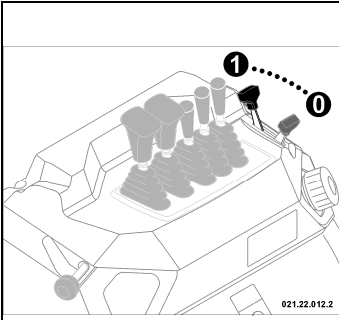
 <p>021.22.012.2</p>	<p>0 STABLE POSITION Minimum regimen</p>
	<p>... STABLE POSITION Intermediate regimen</p>
	<p>1 POSIZIONE STABILE Maximum regimen</p>
<p><i>fig. 25</i> <i>Accelerator command</i></p>	

Drive Levers

The drive levers control the rotation of the tracks through a hydraulic feed to the hydraulic motors.
The levers are active only when the motor is turned on.

Left Drive Lever

The left lever controls the left track.

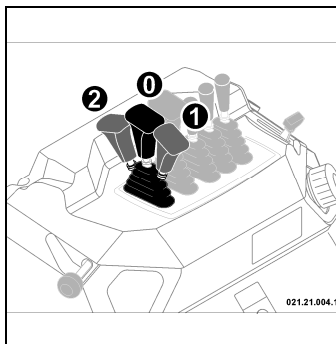

②	UNSTABLE POSITION The left track rotates forward
①	STABLE POSITION Resting position
①	UNSTABLE POSITION The left track rotates backward

fig. 26
Left track command lever

Right Drive Lever

The right lever controls the right track.

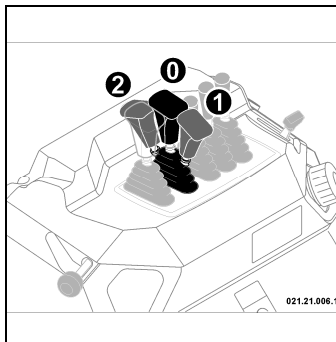

②	UNSTABLE POSITION The right track rotates forward
①	STABLE POSITION Resting position
①	UNSTABLE POSITION The left track rotates backward

fig. 27
Right track command lever

“Hi-Tip” (High Unloading) Command Lever

The command lever the “Hi-Tip” works the hydraulic jack that provokes the raising of the anchoring structure of the body to consent the unloading in containers or tubs with a high border.

The command may be used only when the motor is on.

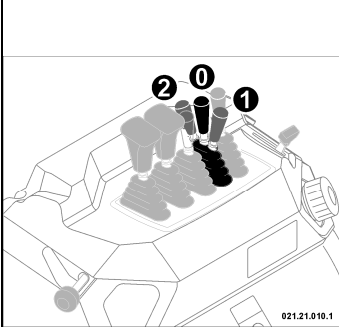
	2	UNSTABLE POSITION Allows the body to be raised
	0	STABLE POSITION Resting position
	1	UNSTABLE POSITION Provokes the lowering of the body
fig. 28 <i>“Hi-Tip” Command Lever</i>		

Command Lever for the Body

The command lever for the body activates the hydraulic jack that activates the tipping of the body.

This position **2** can only be used with the motor turned on, while this position **1** can also be used when the motor is turned off.

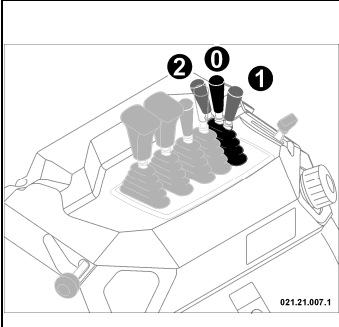
	2	UNSTABLE POSITION The body overturns
	0	STABLE POSITION Resting position
	1	UNSTABLE POSITION The body lowers
fig. 29 <i>Command lever for the body</i>		

Command Lever for the Speed

The command lever for the speed operate on the traction hydraulic circuit, to increase the speed of traslation of the machine.

The position ❶ (Fast) must be used only for long journey.

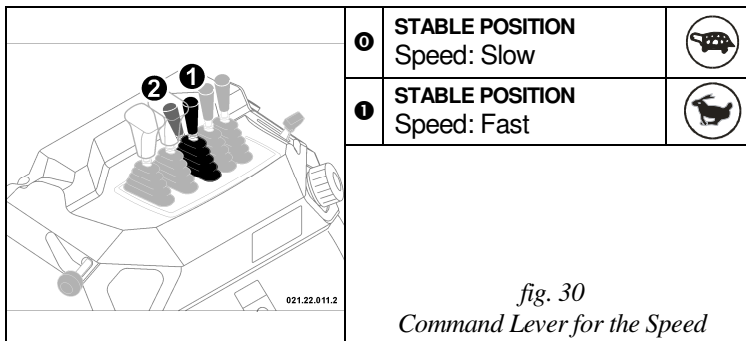

fig. 30
Command Lever for the Speed

Horn Command

The horn button is on the right side of the instrument panel. To sound the horn, push the button. Only intermittent mode horn operation is enabled. Continuous mode is not enabled.

The command works only with the engine running.

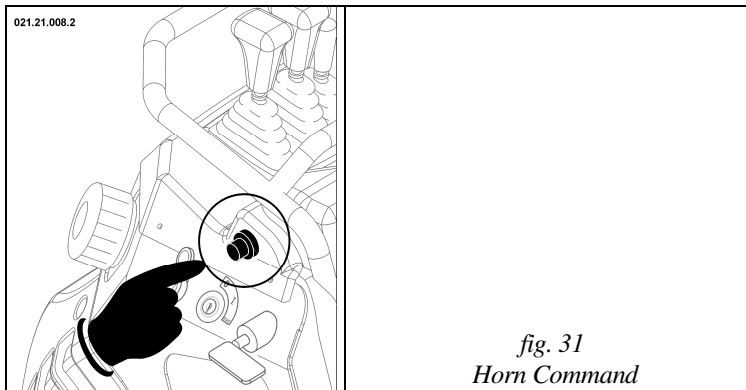
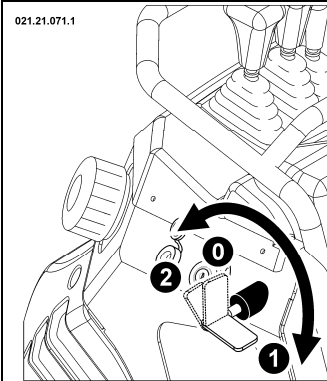

fig. 31
Horn Command

Cut Off Battery Command

The device lever on the right side of the dashboard controls the disconnection of the battery from the electrical circuit of the machine.

Use the cut off battery to disconnect power from the electrical circuit, particularly if the machine stop to work, for a long period of time, can be removed the lever to prevent the discharge of the battery.



①	STABLE POSITION Battery connected
①	STABLE POSITION Battery unplugged
②	STABLE POSITION Battery unplugged, it's possible remove the lever

fig. 32
Cut Off Battery Command

2.2.1. IGNITION CONTROL

The ignition control is on the right side of the dashboard, easily accessible by the operator.

To use the ignition control, is required a dedicated key provided.

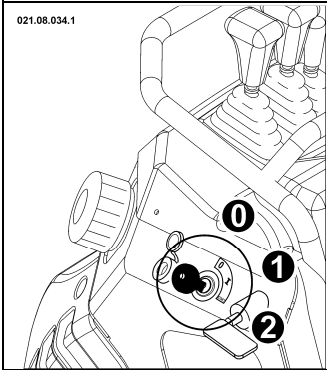

①	STABLE POSITION (OFF) Off
①	STABLE POSITION (MAR) Driving Position
②	UNSTABLE POSITION (AVV) Starting Engine

fig. 33
Ignition Control

3. INSTRUCTION FOR USE

3.1. FIRST USE



READ CAREFULLY: Before using the machine you must read all of the instructions in this manual and the user's and maintenance manual of the motor installed on your machine scrupulously. Furthermore, always keep it attached to the machine.

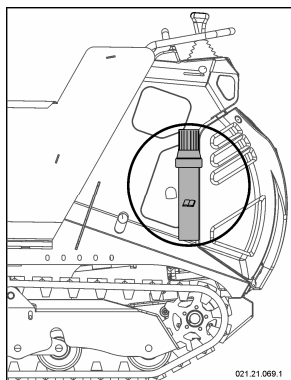

fig. 34

Container for manuals

The owner's manual and maintenance, together with the manual of the engine of the machine, must be always easily available and should be kept in the dedicated container fixed on the machine (*see the fig. 34*).

The machine is normally delivered completely assembled and ready for use with an empty fuel tank.

Fill the fuel tank, open the fuel tap and follow the start-up procedure described in the appropriate paragraph.

3.2. BREAKING-IN PERIOD

The technology used during the construction of your machine does not require a break in period. However, during the first period of use, it is necessary to use these precautions:

- ☞ During the first 50 hours, avoid using the motor at over 70 % of the total power.



READ CAREFULLY: Read the user's manual and the maintenance manual for the motor installed in your machine carefully and follow the instructions prescribed for its own break in period.

- ☞ After the first 20 hours of operation, check the level of the hydraulic oil in the tanks.

☞ During the first period of use, the tracks undergo an adjustment, for which it is necessary, after the first 50 hours of operation, to carry out the regulation of the tension of the tracks.

3.3. MOTOR START-UP

Every time you wish to start up the motor, always verify the following indications scrupulously:

- Always start up the motor outside and be certain that there are no other persons in the vicinity of the machine and/or other impediments.
- Check that there is fuel in the tank and, if necessary, add some.
- Always insert the parking brake.



WARNING: Before turning on the motor, always insert the parking brake to avoid eventual movement of the machine that could present safety issues for the operator.

- Follow the specific procedure prescribed by the constructor of the motor shown in the attached instructions.

When the motor is hot, in petrol operated motors,

avoid inserting the starter.

In diesel engines, can be an automatic valve that helps to raise the start, it works automatically in the first seconds of starting the engine.

3.4. REFUELLING



DANGER: Refuelling must always be done with the engine turned off! Do not smoke while refuelling or while handling fuel to avoid the risk of fire!

Refuelling and /or movement of the fuel from one container to another must always be done outside, always from fires or from other heat sources. Always check that the type of fuel is the correct one, specified for the engine of your machine.

- Position the machine on a clean surface.
- Unscrew the plug slowly.
- Pour the fuel into the tank slowly.
- Screw the plug on again tightly.
- Immediately dry any fuel leakage.



WARNING: Start up the engine only after having made certain that there are no traces of fuel that have accidentally spilled out!



WARNING: The conservation of the fuel must always be done with respect for the specific laws, in suitable places, away from sources of heat, and with clean, well closed suitable containers!



REQUIRED: Avoid the dispersion of fuel and/or fuel containers in the environment. Carry out the disposal according to the current laws and with respect for the environment.

3.5. DRIVING THE MACHINE



DANGER: Always avoid overloading the machine above the prescribed limits: during movement, an overload could create structural variations that were not foreseen and could provoke the overturning of the machine with serious safety consequences.



WARNING: Where possible, try to avoid travelling on rocky or icy terrain, on rails and railway sections because they may damage the tracks and reduce their longevity. Also avoid passing over material that could ruin the tracks, such as sharp objects, pieces of metal, etc. that could get caught up in the tracks and provoke a break.

At the start-up, regulate the number of rotations of the engine to the desired level by activating the accelerator lever, according to the required power (when the machine is loaded, you must bring the lever above the halfway mark between the minimum and maximum).

Under some conditions, especially when the machine is loaded or going uphill, a loss of engine power may occur because of a motor overload; this may also cause it to shut down. In this case, slowly release the drive command lever, regulating the speed to a level that does not provoke an overload of the propeller.

Your machine is equipped with a hydrostatic transmission, so, **it is not necessary that the rotations of the engine be at maximum** for the displacement. Leave the engine operating at its maximum number of rotations does not improve the functioning of the machine, rather, **it certainly (and uselessly) increases its fuel consumption:** it is advisable, therefore, to increase the rotations of the engine only where it is absolutely necessary (to proceed at maximum speed, to address steep slopes with a full load, etc.).

3.5.1. DRIVING POSITION

During the driving of the machine and during the work, is necessary utilize the footrest platform in open position, always (see fig. 35), to prevent risks.

Close the footrest platform only after use.

To use this footrest you must position it in the correct way (see fig. 2):

- Take out the safety pin which blocks the footrest;
- Rotate the platform to the horizontal position;
- Once in position, it will lock by the safety plug spring automatically.

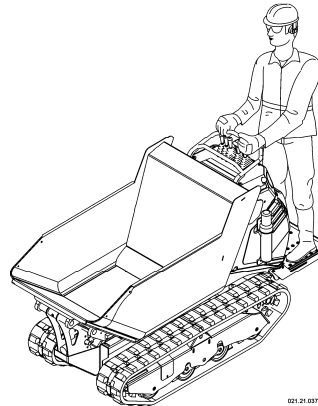

fig. 35 – Driving position



DANGER: Never drive with the footrest unblocked: always verify that the footrest is blocked and that the safety pin is positioned correctly.



WARNING: When you open or close the footrest, be careful with your hands: you may cut yourself or crush them.

When the machine is in gear, always grasp the stronghold handle firmly with one hand and use the other hand simultaneously to activate both drive levers.

Never release the handle to operate the command levers with both hands.



DANGER: When the machine is in gear, the operator must always maintain the prescribed driving position.

Never speed when working, rather proceed at a speed adjusted to your walking speed, in this way you will maintain a safe control over the commands.

3.5.2. FORWARD GEAR

To allow the machine to advance one must activate both drive levers simultaneously by pushing them forward.

Avoid addressing downhill slopes in forward gear, refer to the paragraph: “*Travelling on Slopes*”.

3.5.3. REVERSE GEAR

To allow the machine to back up you must activate both drive levers, pulling them back simultaneously.

Avoid addressing uphill slopes in reverse gear, especially with a loaded machine, rather follow the procedure described in the paragraph: “Travelling on Slopes”.



DANGER: While in reverse gear, always check to see that there are no obstacles and/or persons in the vicinity.

3.5.4. TRAVELLING ON SLOPES



DANGER: Completely avoid working on terrains that have lateral slopes of more than 10° and longitudinal slopes of more than 20° to avoid the possibility of overturning with serious consequences for the safety of the operator.

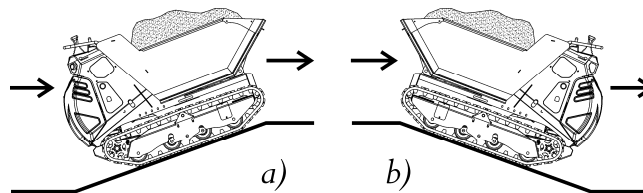

fig. 36 – a) going uphill; b) going downhill

When addressing sloped segments, especially when the machine is loaded, you must use this particular driving technique (*see fig. 36*):

- ☞ Always address the uphill slopes in forward gear;
- ☞ Always address the downhill slopes in reverse gear.

On high slope ground is necessary to work with high regimen of motor (as the slope) minimizing the opening of drive levers (*see fig. 37*); otherwise could be verify cavitation problems and missing the “engine-brake” effect (the hydraulic motors are forced by the slope and they function like a pump): if the machine increase the speed “alone”, release the drive levers.

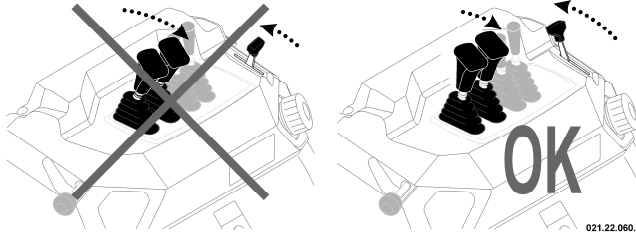

fig. 37 – Motor regimen going downhill



DANGER: if the machine travelling on high slope with minimum motor regimen and maximum opening of drive levers, “engine brake” effect is missing and the machine could increase the speed out of control with the possibility of serious consequences for the safety of operator and the proximity persons.

3.5.5. STOPPING MOVEMENT

To stop movement one must release the drive levers for the tracks simultaneously.

3.5.6. MOVEMENT IN CURVES

To allow the machine to turn one must release the lever on the side to which one intends to turn:

- ☞ To turn to the right, release the right-hand drive lever;
- ☞ To turn to the left, release the left-hand drive lever.

The steering is determined by the slowing of the speed of one track with respect to the other. Consequently the speed and the degree of steering are proportional to the intensity of the release and to the pressure with which you apply to each lever.

3.5.7. COUNTER-ROTATION

It is also possible to make the machine spin round, carrying out a complete “counter-rotation” around its axis, in order to carry out manoeuvres in small spaces.

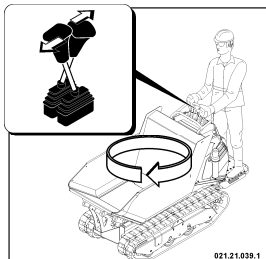

☞ To make a clockwise counter-rotation (towards the direction of the clock hands) you must push the left-hand lever forward and pull the right-hand lever back;

fig. 38 – Clockwise counter-rotation

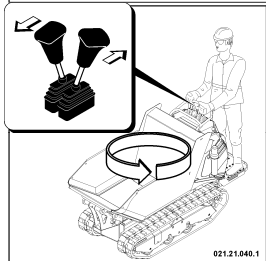

☞ To make a counter-clockwise counter-rotation (towards the opposite direction of clock hands) you must push the right-hand lever forward and pull the left-hand lever back.

fig. 39 – Counterclockwise counter-rotation

Using the counter-rotation manoeuvre often reduces the duration of the rubber tracks, especially if you do it upon rough surfaces.

3.6. STOPPING AND PARKING



WARNING: If you move away from the machine and leave it unattended, always activate the parking brake and be sure that no unauthorized persons may turn it on or move it. In the models which are equipped with one, always take out the start-up key and unplug the battery.

Before stopping the machine, it is preferable to position yourself on a flat paved surface, or on a flat and compact ground.

- Using the accelerator lever, bring the motor down to its minimum number of rotations.
- Insert the parking brake.
- Turn off the engine.
- Close the gas tap (on the models that are equipped with one).

3.7. USING THE PARKING BRAKE

The machine has a safety device nominated as the “**Parking Brake**” which impedes the machine from moving even if the towing commands are activated. This device serves to impede the accidental movement of the machine in the absence of its operator; it also serves as

an emergency stop when the operator may deem necessary to have an instantaneous block of the machine during work.

 **PROHIBITED:** It is strictly prohibited to use the parking brake while the machine is moving to arrest movement of the machine unless in case of emergency.

To activate: Pull the lever lightly towards yourself and move it to the left making it go out of its slot and then let it go: the brake will insert itself automatically.

To deactivate: Pull the lever towards yourself decisively and lightly and move it to the right hooking it into the special slot to block it: the brake has been deactivated.

 **WARNING** – If, when trying to deactivate the brake, the lever resists noticeably, avoid forcing the mechanism in that the wheel may block. Before deactivating the brake, move the machine forward and backward a bit until you have obtained the unblocking of the device.

Emergency Brake: the parking brake serves also as a brake in emergency situations. To carry out an emergency brake, pull the lever towards yourself lightly,

move it towards the left making it come out of the slot and let it go: the brake will insert itself automatically.

 **DANGER:** In the case that you may have to use the emergency brake, consider that this causes the drive mechanism to block instantaneously and may cause a loss of control of the machine.

 **WARNING:** After the emergency brake intervention, have the integrity and the working order of the device verified: a continued use of the machine with an inefficient device could be dangerous for your own safety and that of others.

3.8. TRANSPORTING LOADS

 **PROHIBITED:** It is strictly prohibited to exceed the load capacity limits indicated in the table in paragraph 13.

3.8.1. CONSTRUCTION BODY (DUMPER)

The machine is equipped with a “dumper” type body to transport inert and solid materials, suitable mainly to be used for construction work.

3.9. UNLOADING MATERIAL

3.9.1. OVERTURNING OF THE BODY



WARNING - Before unloading, be certain that the terrain is flat, solid and compact. Carry out the dumping manoeuvre slowly and uniformly. Do not move forward with the machine during the dumping phase.

Your machine is equipped with a hydraulic dumping device for the body which allows for the unloading of material.

To carry out the dumping manoeuvre:

- Position yourself on a level, solid, and compact surface or terrain;
- If the machine is equipped with a **farming body**, unblock the anterior side;
- Push the lever forward to provoke the overturning of the body and the unloading of the material;
- Pull the lever back until the body has returned to travelling position, and then release the lever.



CAUTION: During the unloading, if the body hits up against an obstacle, avoid moving the machine forward: this could damage the junctions of the body!



PROHIBITED: It is strictly prohibited to travel if the body is not in its resting position.

3.9.2. RAISING THE BODY (“HI-TIP”)

On request the machine may be equipped with a hydraulic device to raise the body during the unloading to allow for unloading in containers or tubs with high walls, named “Hi-Tip”.

To unload material normally, use the lever for the overturning of the body (as indicated in the preceding paragraph).

To carry out a high unloading, proceed as follows:

- Position yourself on a level surface or on a level, solid, and compact terrain;
- Use the lever of the auto-loading device pushing it forward to place the shovel on the ground in order to stabilize the machine;
- Raise the body to the desired height by pushing forward the lever for raising;
- Push the overturning lever for the body forward to allow for the unloading of the material.

021.21.022.2

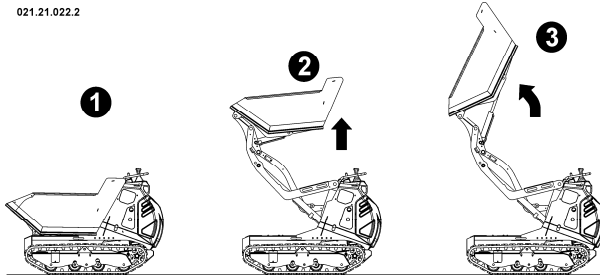

fig. 40 – Position for high unloading

To bring the body back to a driving position, proceed as follows:

- Pull back the overturning lever and bring the body back to a horizontal position;
- Release the command lever for the body
- Pull the lever for raising the body backward until it has reached the driving position;
- Release the raising lever.



DANGER: Never carry out the raising of the body without first stabilizing the machine with the auto-loading shovel.



DANGER: Never, for any reason, activate the raising lever while driving. You could provoke the overturning of the machine

3.10. ACCESSORIES

Your machine can be equipped with some additional devices that make it more complete.

To the side is shown the position of the 12V DC power outlet (see fig. 41) that provides power for operation of electrical devices with additional features highlighted by the close label (see fig. 42).

021.21.072.1

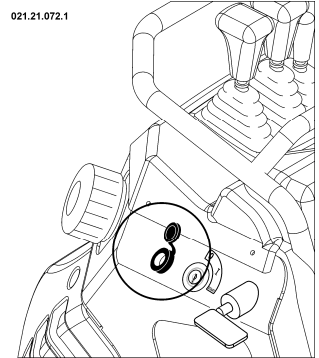

fig. 41 - DC out

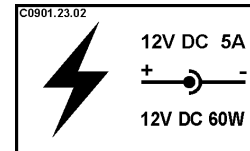

fig. 42 (cod. C0901.23.02)

3.11. TRANSPORT



WARNING: During transport, always position the machine levelly to avoid the spilling of oil or other liquids .

If the machine needs to be transported, one must proceed correctly to avoid dangers to persons and to the machine, if there is any on the machine, **keep down completely the bucket during the transport.** Because of the weight of the machine, it is not possible to move it manually. Thus, it is necessary to use suitable means of lifting to load it onto a means of transport.

The machine is equipped with **4 hooks for lifting** each one with a capacity of 7.000N (700kg) for a **total of 28.000N (2.800kg).**

The position of each hook is indicated with a label like the one shown in the fig. 43 (C0900.13.66).

To do this operation safely you should use, as tools of lifting, 4 ropes with hooks, CE compliant; the two front ropes are 200cm of

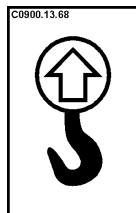

fig. 43
Lifting point

length, and the two rear ropes are 170cm of length, in the following way:

- Disconnect the battery, turning the device to cut off battery;
- Empty the fuel tank and close the plug;
- Fix the lifting hooks exclusively to the anchoring

points that were prescribed by the manufacturer (*fig. 44*);



WARNING: Raise the machine by hooking it exclusively to the hooks predisposed for this purpose: the anchoring of the machine in other points can cause breakage with the consequent fall of the machine and can cause serious harm to persons.

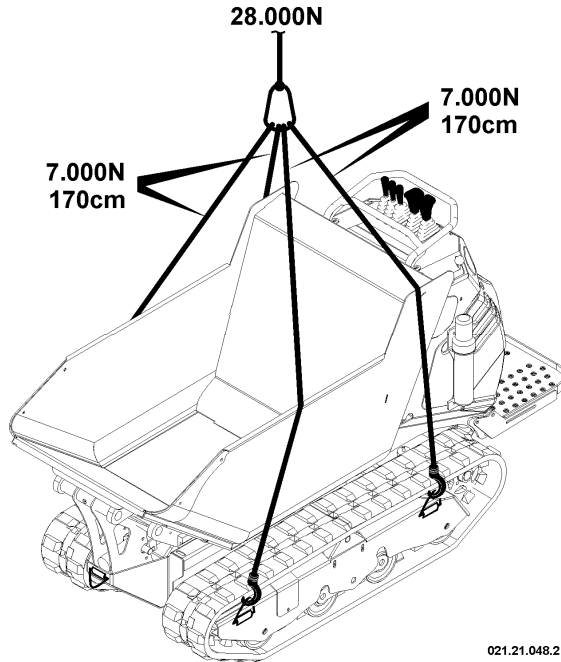

fig. 44 – Anchoring points to lift the machine

- Fix it to the surface of the means of transport pulling down firmly, with CE compliant ropes, and always connecting to the points as indicated in the figure 45.

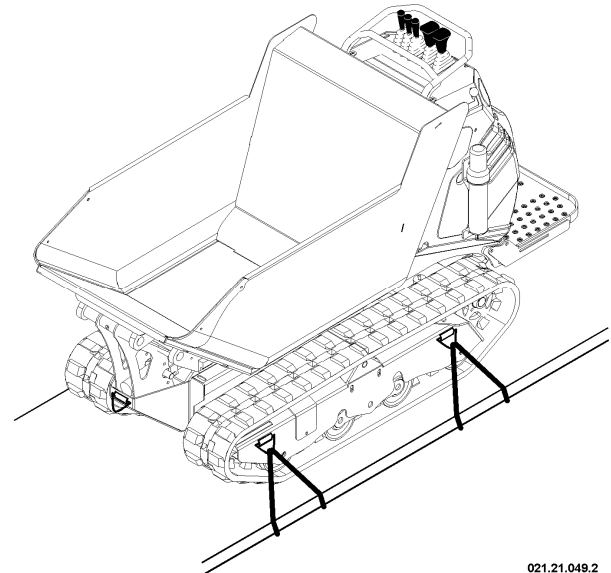

fig. 45 – Anchoring points for transport

3.12. TOWING

The machine is equipped with tow hooks, located at the bottom of the undercarriage, front and rear (see fig. 47); if you need to tow the machine, **take care to emptying the dump body.**

Each anchor point for the towing is evidenced by a label with the symbol shown in figure 46 and can withstand a pull of 10.000N (1.000kg approx).

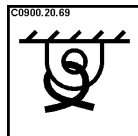

fig. 46
Towing point

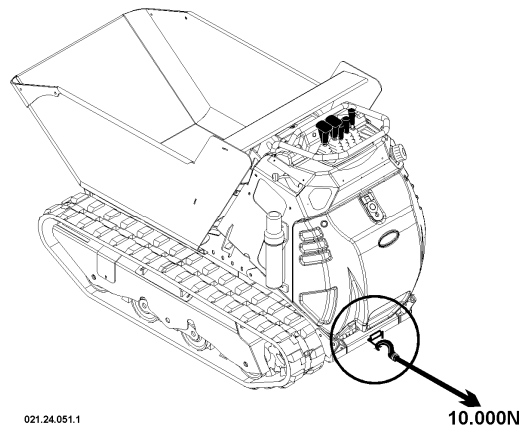
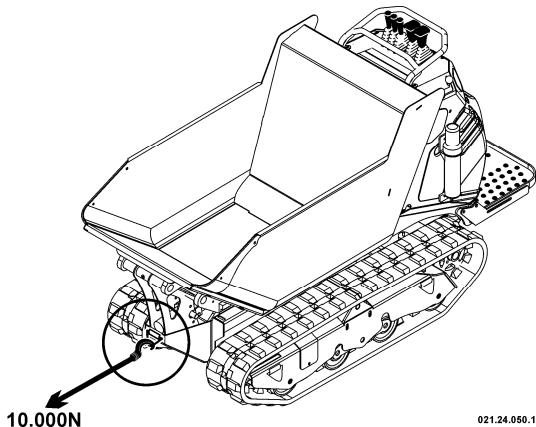

fig. 47 – Anchoring points for towing (front and rear)

3.13. STORAGE

Whenever the machine must remain inactive for several months, it is necessary to provide a correct garaging so that the machine is in perfect working order when it is used again.

In particular one must carry out storage by following all of these instructions:

- Carry out all necessary repairs;

- Disconnect the battery, turning the device to cut off battery;
 - Empty the fuel tank completely;
 - Proceed with a careful cleaning and remove all mud, and/or organic residues carefully;
 - Proceed with all operations regarding the engine that are described in its own manual;
 - Carry out a greasing of all points listed in the specific chapter;
 - Place the machine in such a way that it is sheltered from atmospheric agents under stable conditions and on a flat surface;
 - If the machine is equipped with batteries, unplug them and lubricate with the correct grease;
 - Periodically, every two months, recharge the battery;
 - If the motor is equipped with a start-up key, take it out and conserve in a safe place.
- Proceed with the operations concerning the motor described in its own manual;
 - Check the oil level and add some if necessary.

When putting the machine back into service:

- carry out all greasing again in all prescribed points found in the specific chapter;
- If the machine is equipped with a battery, recharge it and reconnect it being certain of the correct polarity of the ends;
- Insert the cut off battery lever;

4. MAINTENANCE



DANGER: always carry out all maintenance operations with the motor off and with the start up keys not inserted.

A good maintenance is necessary and is the secret to obtaining low running costs, to lengthening the life of your machine, and to always maintaining it at its highest efficiency.

Beyond the normal maintenance operations on the mechanic and hydraulic parts, it is a good rule to carry out a periodic washing of the machine and to proceed with a careful cleaning to take away all mud residues. After every wash it is necessary to grease all of the parts that are subject to friction, as specified in the paragraph "Greasing".

4.1. MAINTENANCE INTERVALS

To maintain the highest level of efficiency, it is necessary that the maintenance be carried out at regular programmed intervals.

In the following table a summary of the maintenance operations is listed that are to be carried out periodically.

() Maintenance and Adjustment Table

<i>Work Frequency</i>	<i>Description</i>	<i>Verify</i>	<i>Greasing</i>	<i>Cleaning</i>	<i>Adjustment</i>	<i>Substitution</i>
Every 8 hours	Machine			✓		
	Drive Levers			✓		
	Command Levers			✓		
	Body		✓			
	Air filter ⁽¹⁾ ⁽²⁾	✓		✓		
	"Hi-Tip" lift		✓			
	Track rollers		✓			
	Motor oil ⁽¹⁾	✓				
Every 50 hours	Tracks				✓	
	Hydraulic oil	✓				
	Air filter ⁽¹⁾ ⁽²⁾			✓		
	Motor oil (1st change)					✓
Every 100 h.	Parking Brake				✓	
Every year or 300 hours	Hydraulic oil					✓
	Hydraulic services oil filter					✓
	Hydraulic drive oil filter					✓
	Dry air filters ⁽¹⁾ ⁽²⁾					✓
	Motor oil ⁽¹⁾					✓
⁽¹⁾ Check with the attached manual for the motor						
⁽²⁾ In dusty areas you must increase the frequency						

4.2. MOTOR



READ CAREFULLY: Carefully read the instructions and the mode of use for the motor found in the attached specific manual.

The machine that was delivered could be equipped at the origin with different engine types for specific needs and/or markets.

A correct maintenance is the best way to conserve the motor of your machine so that it is always working at its highest efficiency and this allows you to maintain low operation costs.

For the maintenance of the motor, pay scrupulous attention to the attached manual that was given to you.

REQUIRED: When changing the motor oil, always use a suitable aspirator to remove old oil.



Avoid the dispersion of oil and filters in the environment and carry out their disposal with respect for the environment and the regulations in force.

4.2.1. PRE-FILTER AND AIR FILTER IN AN OIL BATH

Your machine is equipped with a special air filter with a mushroom pre-filter which increases and improves the filtration capacity.

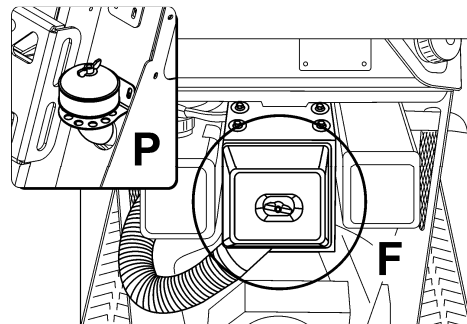

fig. 48- Pre-filter and Air Filter

Pre-filter and filter require periodic maintenance to ensure the smooth operation of the machine. They are easily accessible, in fact the pre-filter "P" is positioned in front of the dashboard on the left side, while the cartridge filter is visible by opening the engine hood (see fig. 48).

The maintenance of the pre-filter "P" counts the **cleaning every 8 hours** as shown below.

Raise the dump body to facilitate the operation.

Unscrew the wing bolt (*see fig. 49*), which blocks the cover of the pre-filter, remove the section in clear plastic "T", clean it using a simple washing with water and reconnect it.

For the maintenance of the air filter "F", is necessary to open the engine hood.

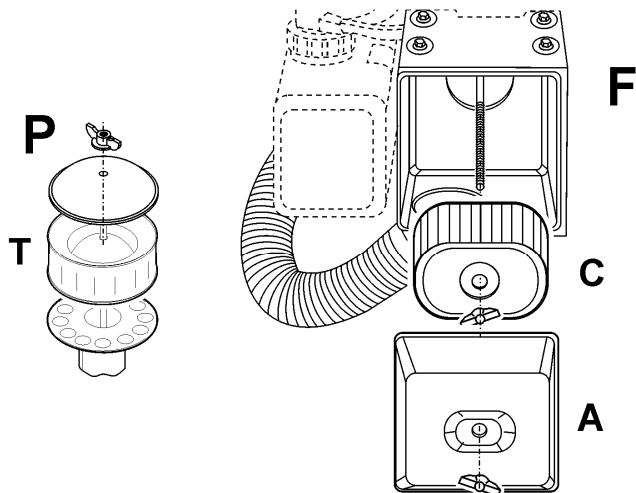

fig. 49 – Cleaning and substitution

Once you open the bonnet, the air filter is easily accessible. Unscrew the wing bolt the cover "A" to enter the cartridge "C", which is held in place by another wing bolt (*see fig. 49*).

Every 50 hours remove the filter "C" from its holder and carefully cleaned by blowing with compressed air.

Every 300 hours at least once a year, replace the air filter cartridge, "C" following the same procedure for cleaning described above.

4.3. HYDRAULIC CIRCUIT

4.3.1. HYDRAULIC OIL



REQUIRED: Avoid the dispersion of oil in the environment and carry out the disposal with respect for the environment and the regulations in force.

Verifying Oil Level

Every 8 hrs

Check the correct level of hydraulic oil in the tank.

To verify the correct hydraulic oil level, the machine will be placed on a solid and flat surface.

You have the correct level when cold, the oil does not exceed the mark on the dipstick (about $\frac{3}{4}$ of the tank) and does not fall below the mark of more than 1 cm (*s. fig. 50*).

Restoring Oil Level

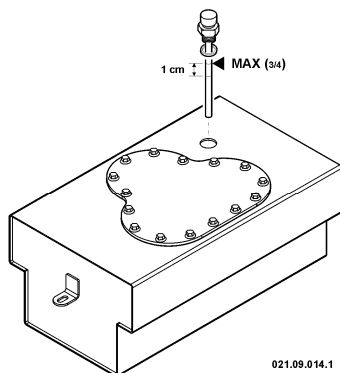

fig. 50 – Oil level

command levers.

Stop the engine and check that the level of the hydraulic oil reaches the correct level, and if necessary, repeat the previous operations.

- Unscrew the vent plug with the gasket of the tank;
- Restore the level by adding the oil specified into the hole;
- Screw the vent plug with his gasket and and turn on the engine following the correct procedure;
- Briefly operate the drive levers and the

Substitution

Every 300 hrs

Substitute the hydraulic oil in the tank.

To substitute the hydraulic oil, use a suitable aspirator and work when the oil is cool, verifying its temperature using the thermometer.



DANGER: The hydraulic oil can reach high temperatures, especially after a day of work: avoid substituting the oil when it is hot to avoid the risk of burning yourself.



DANGER: Always carry out the emptying when the motor is off and with the body blocked with the safety bar device.

- Empty the oil tank first (*see fig. 51*);
- Unscrew the vent plug “A” on the tank, removing the washer “B”, and aspirate the oil using a suitable aspirator;
- Fill the tank through the hole “C” of vent plug, to reach the upper mark on the dipstick;
- Screw the vent plug “A”, placing the gasket “B” and start the engine;
- Briefly move the drive levers and the command levers;
- Stop the engine and check that the level of the

Replacement

- Empty the oil tanks, by following the procedure described in the preceding paragraph;
- Remove the screws "M" of the oil tank cover;
- First, replace the filter "H" fitted directly into the hydraulic oil tank;
- Unscrew the nipple of connection "G";
- Replace the filter "H" and screw the nipple being careful to position the gasket;
- To change the filter "E" is necessary to loosen the sleeve of the connector "F";
- Unscrew the filter "E" from the sleeve;
- Screw the connector "F" on the new filter "E" inserting the gasket;
- Tighten the hose to the inlet pipe in the tank;
- After replacing the filter, apply the sealant "s" resistant to high temperatures on the edge of the cover, put the cover on the tank and tighten the screws "M";
- Fill the tank and check the hydraulic oil level as above (see the table of the oils at the end of cap.4).

4.4. TRACKS

Registration

Every 50 hrs Register the tension of the tracks.

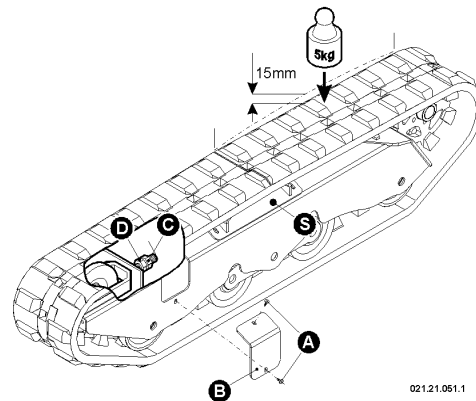

fig. 52 - Track Tension Regulation

The correct tension of the tracks is important in order to guarantee their longevity and for your own safety: to check it, apply a pressure of 5 kg on the track and check that the arrow is at about 15mm.

To carry out the regulation of the tension of the tracks correctly:

- Take off the cover "B" by removing the two screws "A";
- Using two wrenches, loosen the counter-nut "C";
- Regulate the tension by working on nut "D";

- Make sure the arrow is 15 mm near the middle, front or back to the slide "S" of the track (see fig. 52);
- When you have finished regulating, block the counter-nut "C";
- Put the cover back on;
- Repeat the same procedure on the other track.

Replacemen

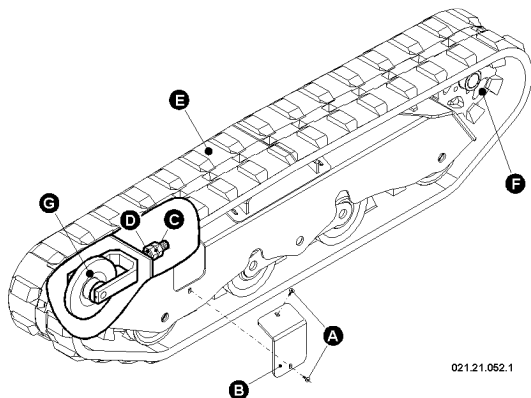

fig. 53 - Substitution of tracks

For the substitution of the tracks, proceed as follows:

- Raise the side of the machine on which you wish to

work using hydraulic jacks or a crane;

- Position the machine on suitable trestles, and check to see that it is stable;
- Take off the cover "B" by removing the two screws "A";
- Using two wrenches, loosen the counter-nut "C" and unscrew both the counter-nut and the nut "D" loosen completely the track "E";
-
- Remove the track "E" starting from the front side;
- Mount the new track lining it up with the teeth in the drive wheel "F";
- Fit in the anterior part of the track onto the neutral wheel "G";
- Register the tension by working on the nut "D";
- Make sure the arrow is 15 mm near the middle, front or back to the slide "S" of the track (see fig. 52);
- When the registering is done, block the counter-nut "C";
- Put the cover back on.



DANGER: Never work with the machine raised on a jack or suspended, rather always place it upon suitable trestles that can maintain the weight of the machine before starting work.

4.5. PARKING BRAKE

Registering

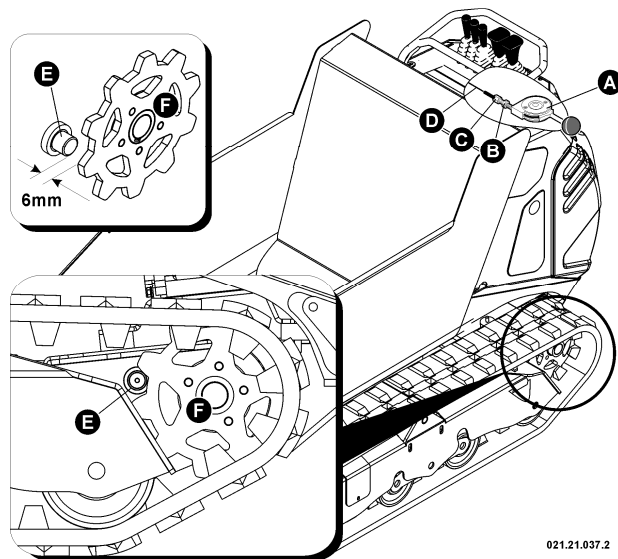

021.21.037.2

fig. 54 – Regulation of parking brake

To register the parking brake, first of all you must remove the plastic panel by unscrewing the screws along,

and all the control levers.

At this point you can access to the throttle "A" on the left side of the dashboard.

The correct adjustment of the parking brake is when the cursor "E" is at least 6mm from the driving wheel "F".

To register proceed as follows:

- Make sure the brake "A" is disengaged;
- Unscrew the lock-nut "B" of register "C";
- Adjust the cable tension "D" operating on the register "C";
- Check the correct position of the cursor "E", which is at least 6mm from the drive wheel;
- Tighten the counter-nut "B";

Restore the plastic panel and control levers.

4.6. GREASING

Every 8 hrs

Refurnish the grease in all prescribed points.

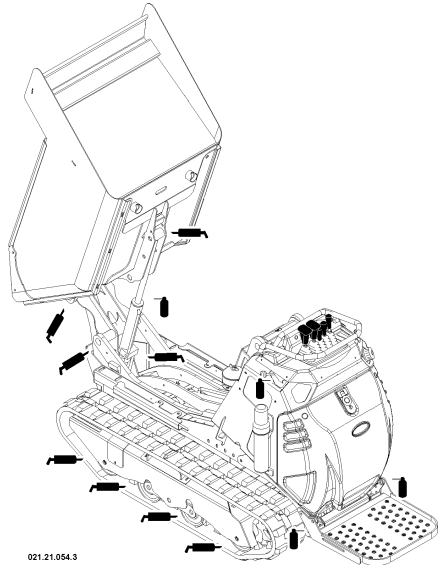

021.21.054.3

fig. 55 – Greasing points

Refurnish the grease in all prescribed greasing points, using a suitable grease.

Also, grease the drive levers using a spray type lubricant.

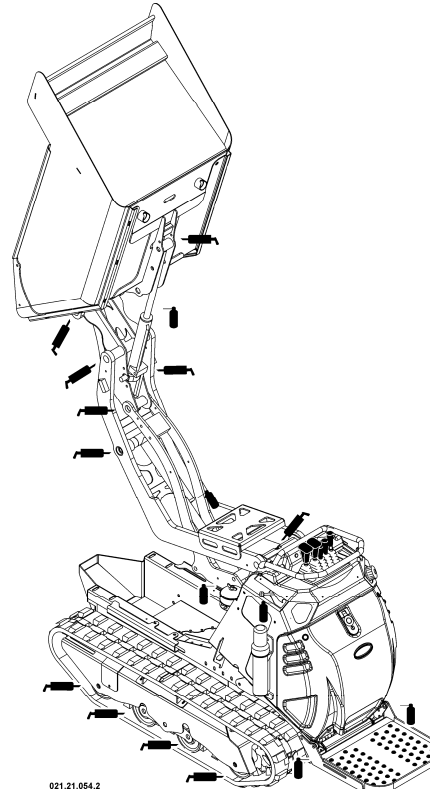

021.21.054.2

fig. 56 – Hi-Tip greasing points

4.7. RECOMMENDED LUBRICANTS

	<i>Type</i>	<i>Quantity</i>
Motor Oil	15W40	
Hydraulic Oil	AT FII	16 l
Grease	MR thick fluid	

5. INCONVENIENCES AND BREAKDOWNS

Inconvenience	Causes	Remedy
Hydraulic oil is leaking.	Excessive oil level.	Correct the oil level
	Overheated oil.	Turn off the machine and let it cool down
	Breakdown in the hydraulic circuits.	Have the machine looked at by a mechanic with specific competence
Oil leak.	Excessive oil level.	Correct the oil level
	Breakdown in hydraulic circuits or in washers.	Have the machine looked at by a mechanic with specific competence
The hydraulic commands do not respond correctly.	Insufficient oil level.	Refill to the correct level
	Breakdown in the hydraulic circuits.	Have the machine looked at by a mechanic with specific competence
The body or the arms of the bucket moves slowly.	Overheating of the oil.	Interrupt work and let it cool down
	The motor does not have power.	Have the machine looked at by a mechanic with specific competence
Excessive oil temperature.	Insufficient oil level.	Refill to the correct level
	Overheating.	Interrupt work and let cool down
Parking brake does not deactivate.	The brake cable is broken.	Have the cable substituted by a mechanic
	The brake is blocked.	Move the machine slightly forward and backward and try again

Inconvenience	Causes	Remedy
The machine does not move.	The parking brake is activated.	Deactivate the parking brake
	Not enough oil in the hydraulic circuit.	Restore oil to the correct level
	The tracks are broken.	Replace the tracks
	Breakdown in the hydraulic components.	Have the motor looked at by a mechanic with this specific competence
Excessive noise from the tracks during movement.	Incorrect track tension.	Register the tension.
	Broken or worn tracks.	Replace the tracks.
	Broken rollers or ball bearings.	Have the motor looked at by a mechanic with this specific competence
Excessive noise from the dump body.	Needs greasing..	Greasing
	Broken rollers.	Have the machine repaired by a mechanic
The accelerator does not respond.	Il cavo dell'acceleratore è rotto.	Fate sostituire il cavo da un'officina meccanica
The motor does not work correctly or makes an excessive amount of noise.	Various causes.	Have the motor looked at by a mechanic with this specific competence
The motor does not develop power.	The air filter is blocked.	Replace the air filter.
	Various causes.	Have the motor looked at by a mechanic with this specific competence
The motor does not start.	Not enough fuel.	Refuel the machine
	The start-up procedure was not carried out correctly.	Follow the correct start-up procedure
	The battery is dead.	Have the battery recharged or replace it

6. INDEX

Accelerator		Body Lever	21	Forward	27
Command Lever	14	Drive Lever	15; 20	Reverse	28
Command Lever-Registration	19	High Unloading Lever	21	general information	1
Registration	<i>See Attached</i>	Hi-Tip Lever	21	Goal of the Manual	1
Accessories	7; 33	Lever for the Body	16	Greasing	
Air Filter		Lever for the Speed	16; 22	Points of -	45
Cleaning	<i>See Attached</i>	Parking Brake Command	14	High Unloading, Command Lever	21
Substitution	<i>See Attached</i>	Parking Brake Lever	19	Hi-Tip	
Blocking the Body	5	Commands	14	Command Lever-	21
Blocking the Footrest	6	Hi-Tip Version	19	Raising the Body	32
Blocking the Lift	6	Hydraulic Overturning Version	14	Horn	
Body		Conter-rotation	29	Comnd	17; 22
Blocking the	5	Curves, Movement in -	29	Horn Command	17; 22
Command Lever-	16; 21	Cut Off Battery		Hydraulic	
Construction (Dumper)	31	Command	17; 23	Circuit -, Maintenance	40
Overturning of the -	32	Cut Off Battery Command	17; 23	Hydraulic Oil	40
Raising (Hi-Tip)	32	Dimensions	12	Restoring Level	41
Brake		Drive		Substitution	41
Command Lever	14; 19	Levers of -	15; 20	Verifying Temperature	41
of Emergency	31	Driving		Identification Plate	5
of Emergency, Using	31	the Machine	26	Ignition Control	18; 23
of Parking	30	Driving		Inconveniences and breakdown	48
of Parking, Registering	45	Position	27	Instruction for use	24
of Parking, Mainutenance	45	Dumper, Construction Body	31	Introduction	2
of Parking, Using	30	Emergency, Brake of -	31	Level	
breakdown, Inconveniences and -	48	First Use	24	Motor Oil	<i>See Attached</i>
Breaking-in Period	24	Footrest		Lever	
Cleaning Air Filter	<i>See Attached</i>	Blocking the	6	Accelerator Command	14
Command		Forward, Gear -	27	Command of the Body	16
Accelerator Lever	14; 19	Gear		Command of the Speed	16; 22

of Body Command	21	Substitution - Drive	42	Cutting	9
of Drive	15; 20	Olio Idraulico	39	Fan	9
of High Unloading Command	21	Sostituzione	40	Hot Surface	9
of Hi-Tip Command	21	Verifica Livello	40	Maximum Slopes	10
of Parking Brake Command	19	Other Tags	11	Safety Distance	9
Parking Brake Command	14	Overturning of the Body	32	Safety Tags	8
Lever of Accelerator Command	19	Parking		Caution	9
Lift		Brake of -	30	Slopes	
Blocking the	6	Brake of -, Maintenance	45	Travelling on -	28
Livello		Stopping and -	30	Sostituzione	
Olio Idraulico	40	Pendenze		Olio Idraulico	40
Machine		Ammisibili	11	Speed	
Description of the -	2	Raising the Body (Hi-Tip)	32	Command Lever-	16; 22
Driving the -	26	Recommended Lubricants	47	Stopping	
Identification of the -	5	Refuelling	25	and Parking	30
Machine and Manufacturer Identification	5	Registering		of Movement	29
Machine Description	2	Parking Brake	45	Storage	36
Maintenance	38	Registration		Substitution	
Maintenance, Intervals of -	38	Accelerator	<i>See Attached</i>	Air Filter	<i>See Attached</i>
Manual, Goal of the -	1	Minimum	<i>See Attached</i>	Drive Oil Filter	42
Manufacturer, Identification of -	5	Tracks	43	Hydraulic Oil	41
Minimum, Regimen Registration	<i>See Attached</i>	Restore		Motor Oil	<i>See Attached</i>
Motor		Hydraulic Oil Level	41	Tracks	44
Maintenance	39; <i>See Attached</i>	Restoring		Targhetta di Sicurezza	
Start-up of -	25	Level Motor Oil	<i>See Attached</i>	Marcia sulle Pendenze	33
Motor Oil		Reverse, Gear -	28	Technical Data	13
Substitution	<i>See Attached</i>	Safety		Towing	36
Verify Level	<i>See Attached</i>	Devices of -	5	Tracks	43
Motor Start-up	25	Information about -	3	Registration	43
Movement		Tags -	8	Substitution	44
in Curves	29	Safety Devices	5	Transport	34
Stopping of -	29	Safety information	3	Travelling	
Oil Filter		Safety Tag		on Slopes	28
Hydraulic	42	Crushing	9	Unloading Material	32

Use	
Instruction for -	24
Using	
Emergency Brake	31
of Parking Brake	30
Verifica	
Livello Olio Idraulico	40
Verify	
Hydraulic Oil Temperature	41
Motor Oil Level	<i>See Attached</i>
Warranty	1

7. SUMMARY

Introduction	2	1.10. Technical Data	13
1. General Information	1	2. Commands	14
1.1. Warranty	1	2.1. Hydraulic Overturning Version	14
1.2. Goal of the Manual	1	2.1.1. Ignition Control	18
1.3. Machine Description	2	2.2. “Hi-Tip” Version	19
1.4. Safety Information	3	2.2.1. Ignition Control	23
1.5. Machine and Manufacturer Identification	5	3. Instruction for use	24
1.6. Safety Devices	5	3.1. First Use	24
1.6.1. Blocking the Body	5	3.2. Breaking-in Period	24
1.6.2. Blocking the Footrest	6	3.3. Motor Start-up	25
1.6.3. Blocking the Lift (“Hi-Tip”)	6	3.4. Refuelling	25
1.7. Accessories	7	3.5. Driving the Machine	26
1.8. Safety Tags	8	3.5.1. Driving Position	27
1.8.1. Safety Distance	9	3.5.2. Forward Gear	27
1.8.2. Hot Surface	9	3.5.3. Reverse Gear	28
1.8.3. Fan	9	3.5.4. Travelling on Slopes	28
1.8.4. Crushing	9	3.5.5. Stopping Movement	29
1.8.5. Cutting	9	3.5.6. Movement in Curves	29
1.8.6. Procedure for Caution	9	3.5.7. Counter-rotation	29
1.8.7. Maximum Slopes	10	3.6. Stopping and Parking	30
1.8.8. Procedure for Addressing Slopes	10	3.7. Using the Parking Brake	30
1.8.9. Other Tags	11	3.8. Transporting Loads	31
Admissible Slopes	11	3.8.1. Construction Body (Dumper)	31
1.9. Dimensions	12	3.9. Unloading Material	32

3.9.1. Overturning of the Body	32
3.9.2. Raising the Body (“Hi-Tip”)	32
3.10. Accessories.....	33
3.11. Transport.....	34
3.12. Towing	36
3.13. Storage	36
4. Maintenance	38
4.1. Maintenance Intervals	38
4.2. Motor.....	39
4.2.1. Pre-filter and Air Filter in an oil bath.....	39
4.3. Hydraulic Circuit.....	40
4.3.1. Hydraulic Oil	40
4.3.2. Hydraulic Oil Filters	42
4.4. Tracks.....	43
4.5. Parking Brake.....	45
4.6. Greasing	45
4.7. Recommended Lubricants.....	47
5. Inconveniences and breakdowns	48
6. Index.....	50
7. Summary	53

		CORMIDI S.R.L. VIA FONTE 342 84069 - ROCCADASPIDE - SALERNO TEL.: +39 0828.943688 - FAX: +39 0828.943963	
<u>DICHIARAZIONE CE DI CONFORMITA'</u> <u>EC DECLARATION OF CONFORMITY</u>			
Il sottoscritto, detentore della documentazione tecnica, dichiara che la sottoindicata macchina è stata progettata e costruita in conformità alle seguenti Direttive Europee, come emendate, alle norme armonizzate citate e ai decreti e regolamenti che le traspongono nelle leggi nazionali: The undersigned, holder of the technical documentation, declares that the machine described below has been designed and manufactured in compliance with the following European Directives, as amended, the European Standards and the regulations transposing them into national laws:			
1. 2004/42/CE "SICUREZZA DELLE MACCHINE/SAFETY OF MACHINERY"			
1.1 NORME EUROPEE ARMONIZZATE NEL CUI RISPETTO LA CONFORMITA' E DICHIARATA: EUROPEAN HARMONIZED STANDARDS IN WHOM CONFORMITY IS DECLARED: EN 474-1:2004 + X EN 474-3:2004 + X EN ISO 3471:2006 + X EN ISO 12100:2009			
1.2 PRINCIPALI COMPONENTI DI SICUREZZA MONTATI E FORNITI CON LA MACCHINA MAIN SAFETY COMPONENTS INSTALLED AND SUPPLIED WITH THE MACHINE A1-2009			
1.2.1 VARIANTE PER LA MOVIMENTAZIONE DEI CARICHI SOPEI OBJECT HANDLING APPLICATION (EN 474-5 FORNITI ALI 1.7.3 - 4.1.7.5)			
1.2.2 STRUTTURA DI PROTEZIONE CONTRO LA CADUTA DEGLI OGGETTI (F.O.P.S.) FALLING OBJECT PROTECTIVE STRUCTURE (F.O.P.S.)			
2. 2000/14/CE "EMMISSIONE ACUSTICA/NOISE EMISSION"			
2.1 PROCEDURA DI VALUTAZIONE DELLA CONFORMITA' SECONDO L'ALLEGATO VI (ART. 4/1) CONFORMITY ASSESSMENT PROCEDURE FOLLOWED			
2.2 NOME ED INDIRIZZO DELL'ORGANISMO NOTIFICATO COMPETENTE NAME AND ADDRESS OF THE NOTIFIED BODY BY WHICH CONFORMITY IS DECLARED: ECO CERTIFICAZIONI SPA (N. 0714) - BALI VIA MENGOUNA, 33 - FAENZA (RA)			
2.3 LIVELLO DI POTENZA SONORA MISURATO LWA (REF. 1 P) MEASURED SOUND POWER LEVEL LWA (REF. 1 P)			
2.4 LIVELLO DI POTENZA SONORA GARANTITO LWA (REF. 1 P) GUARANTEED SOUND POWER LEVEL LWA (REF. 1 P)			
2.5 POTENZA NETTA MOTORE IN CONFORMITA' CON LA DIRETTIVA 97/48/CE ENGINE NET INSTALLED POWER IN ACCORDANCE WITH THE EUROPEAN DIRECTIVE 97/48/CE			
3. 2004/108/CE "COMPATIBILITA' ELETTRICA/EMISSIONE ELETTRICA/EMISSIONE ELETTRICA"			
3.1 NORME EUROPEE ARMONIZZATE NEL CUI RISPETTO LA CONFORMITA' E DICHIARATA EUROPEAN HARMONIZED STANDARDS IN WHOM CONFORMITY IS DECLARED: EN 13309:2000			
4. ALIQUOTI DI DIRETTIVE EUROPEE APPLICABILI/OTHER APPLICABLE DIRECTIVE(S):			
5. COGNOME E NOME DELL'ORGANISMO NOTIFICATO COMPETENTE SURNAME AND NAME OF THE NOTIFIED BODY BY WHICH CONFORMITY IS DECLARED: CORMIDI S.R.L. - VIA FONTE 342 - 84069 - ROCCADASPIDE - SALERNO			
6. MACCHINA/TYPE OF MACHINE:			
Motoribullabile a cingolo compatti / crawler			
7. TIPO/TYP:			
C5-60 DHE			
8. MATRICOLA N°/SERIAL N°:			
ANNO DI COSTRUZIONE/CONSTRUCTION YEAR: 2010			
10. PERSONA AUTORIZZATA A COSTRUIRE IL FASCICOLO TECNICO/PERSON AUTHORISED TO COMPILE THE RELEVANT TECHNICAL DOCUMENTATION:			
ARMANDO CORMIDI - VIA FONTE, 342 - 84069 ROCCADASPIDE (SA)			
DICHIARAZIONE N° <input type="text"/>			
ROCCADASPIDE			