

# downunder

BARBEQUES GALORE®

## INSTRUCTIONS

For safe use and enjoyment of your new barbeque

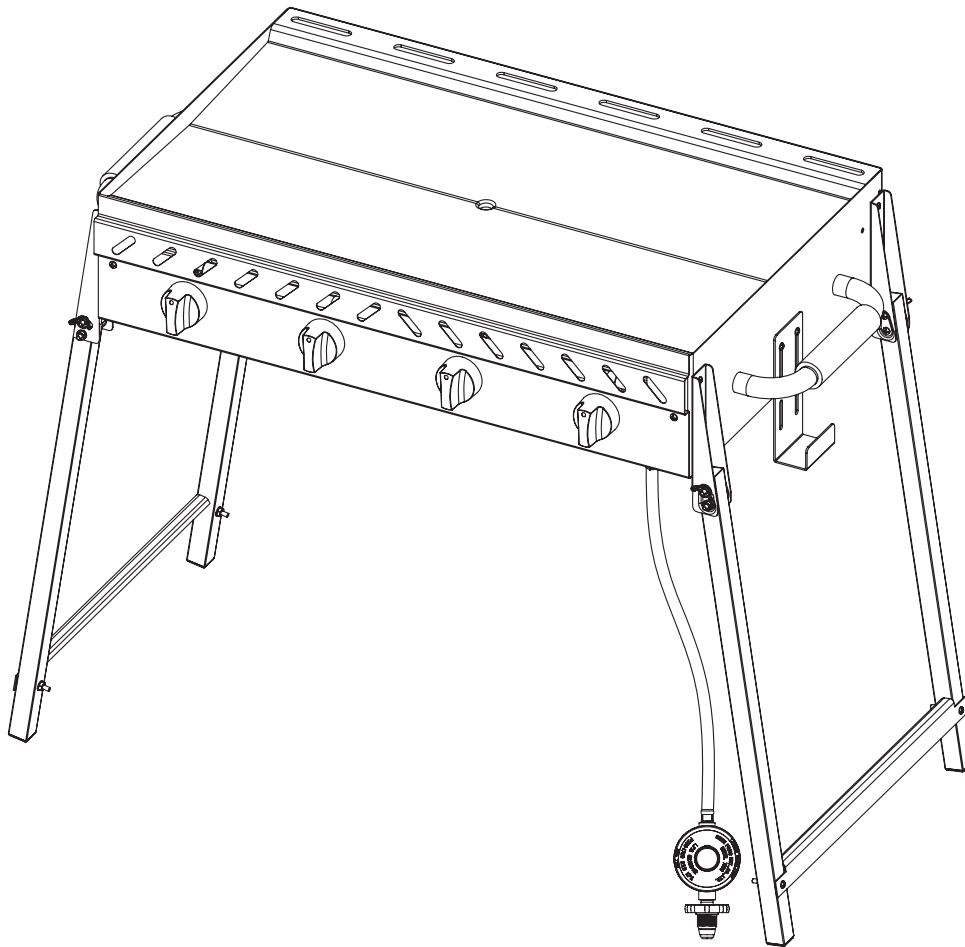

**BARBEQUES  
GALORE**

4 Burner Solid Hotplate  
Barbeque With Folding  
Legs  
G4DLK (BGW4NH007S)

# **IMPORTANT HEALTH & SAFETY INFORMATION**

## **1. WARNING:**

**FOR OUTDOOR USE ONLY ! DO NOT USE INDOORS**

- Please read these instructions carefully prior to assembly and use.
- Failure to follow these instructions could lead to serious injury and/or significant damage to property.
- Do not start the barbeque if there is any doubt over the correct assembly, ignition, gas control or cooking of the unit.
- These instructions should be retained for future reference.
- For use with PROPANE gas cylinder only.
- The barbeque must have a minimum side clearance from any combustible material of at least 250mm. Additionally there must be a clearance of at least 1500mm above the cooking surface of the barbeque.
- Flammable materials and liquids must be stored well away from the barbeque.
- Aerosols must not be used near the barbeque.
- The barbeque should not be moved when lit or hot.
- A lit barbeque should be attended at all times.
- Gas cylinders MUST be stored and used vertically only.
- Never attempt to ignite the barbeque with the main hood or side burner lid closed.
- Avoid dousing the barbeque with water.
- Turn off the gas cylinder when the barbeque is not in use;
- Always allow the barbeque to completely cool down before covering.
- For safety reasons it is advisable to keep a fire extinguisher and fire blanket close to hand.
- Unsupervised children, elderly and infirm should not be allowed close to the barbeque during pre-heat, cooking, burn off or cooling down of the unit.
- Please dispose of all polythene packing and plastic bags carefully and keep out of the reach of children.

## **2. GAS TYPE AND REGULATOR:**

- This barbeque is designed to run from a PROPANE gas cylinder only.
- To ensure maximum performance a gas cylinder of 9kg is recommended.
- The regulator as supplied should be firmly tightened but care must be taken not to over-tighten the connections.
- The regulator as supplied is the correct regulator for this item.
- Do not attempt to connect gas to a barbeque that is not properly secured on the gas cylinder hook.

## **3. IF YOU SMELL GAS:**

**DO NOT ATTEMPT TO OPERATE THE BARBEQUE UNTIL THE CAUSE OF THE GAS SMELL HAS BEEN IDENTIFIED AND ELIMINATED**

- Immediately isolate the gas supply by turning the gas off at the cylinder.
- Extinguish all naked flames.
- Do not operate any electrical devices close to the barbeque.
- Check for leaks as described in section 4: Precautionary Leak Test.
- Ensure that local area is well ventilated to remove any excess gas.
- If the gas smell continues the barbeque should not be operated under any circumstances and it is important to make immediate contact with your store of purchase.





#### 4. PRECAUTIONS:

### **BEFORE FIRST TIME OPERATION AND AFTER EACH GAS CYLINDER EXCHANGE/REFILL ALL CONNECTIONS SHOULD BE CHECKED FOR GAS LEAKS**

- Connections can be checked for leaks by using a soapy water solution as described in section 4: Precautionary Leak Test.
- Naked flames (matches or other open flames) must not be used to check for leaks, this is a dangerous practice to be avoided.
- Flammable liquids of any description, including petrol, lighter fluid, oils, etc must not be stored close to the barbeque.
- Spare or extra gas cylinders must NOT be stored within close proximity of this barbeque or any other gas or electric appliance.
- Spare or extra gas cylinders should not be stored where they are exposed to continuous direct sunlight, as this is a potentially dangerous practice.
- The position of the assembled barbeque should be such that the gas cylinder is not left exposed to direct sunlight as this is a potentially dangerous situation.
- Please read and follow all instructions in this manual, if in doubt as to any operational or safety precaution contact the customer service centre.
- Please ensure the gas cylinder is positioned outside of the Barbeque frame. It must not be positioned underneath the barbeque.
- For storage and gas cylinder exchange, disconnect the gas cylinder only. Do not disconnect hose from the appliance.

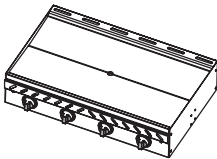
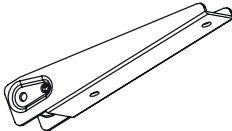

# ASSEMBLY INSTRUCTIONS

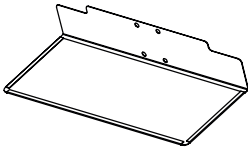
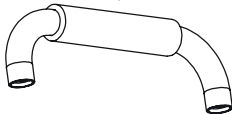
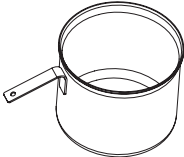
## PARTS LIST

	ITEM DESCRIPTION	QUANITY	PICTURE
<b>1</b>	FIRE-BOX ASSEMBLY	1	
<b>2</b>	LEG SUPPORT BRACKET	4	
<b>3</b>	LEG	4	
<b>4</b>	LEG CROSS BRACE	2	
<b>5</b>	GAS CYLINDER HOOK	1	
<b>6</b>	HEAT INSULATION PANEL	1	
<b>7</b>	HANDLE	2	
<b>8</b>	GREASE CUP	1	

# ASSEMBLY INSTRUCTIONS

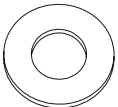
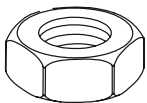
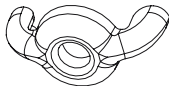
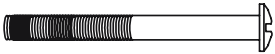
## FASTENERS

	ITEM DESCRPTION	QUANITY	PICTURE
<b>A</b>	M6 X 12MM SHORT PHILLIPS HEAD SCREW	12	
<b>B</b>	M6 STEEL WASHERS	12	
<b>C</b>	M6 NUTS	8	
<b>D</b>	M6 WING NUTS	4	
<b>E</b>	M6 X 40MM LONG PHILLIPS HEAD SCREW	12	
<b>F</b>	M6 X 16MM MEDIUM PHILLIPS HEAD SCREW	4	

# ASSEMBLY INSTRUCTIONS

**Note:** Steps 1 to 4 are best done with the barbecue carefully resting on its back as shown in Step 1

## Step 1

Attach the leg support brackets to the firebox using short screw (A). Eight of the nuts (closest to the hot plate) are pre installed for your convenience.

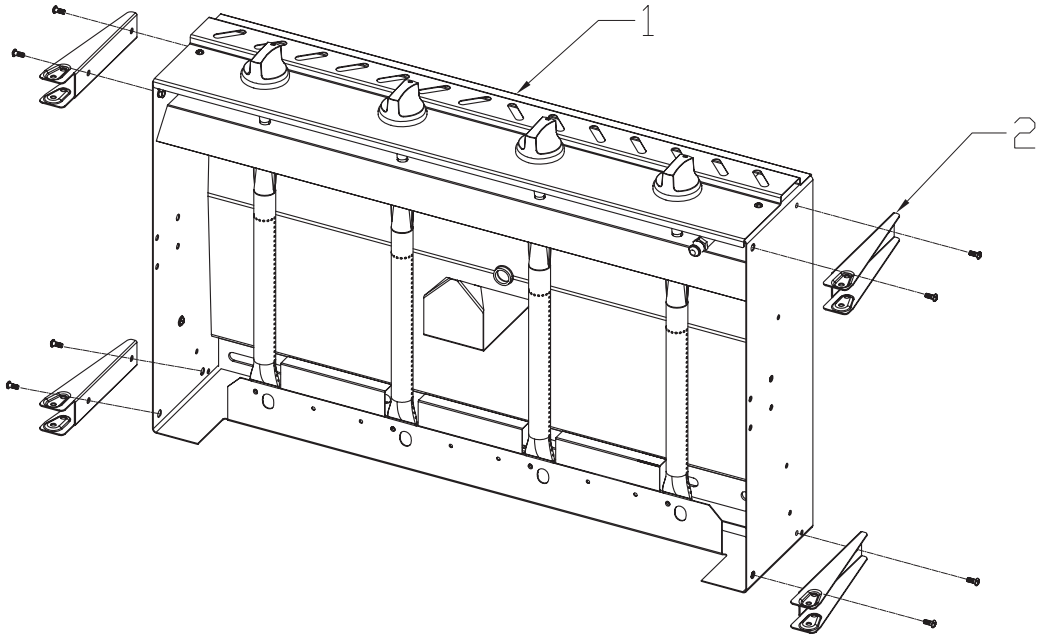

A  8PCS SHORT SCREWS

## Step 2

Attach the legs to the leg support bracket using long screws (E), washers (B), nuts (C) and wingnuts (D). Then attach the leg cross brace using (E), (B) and (C).

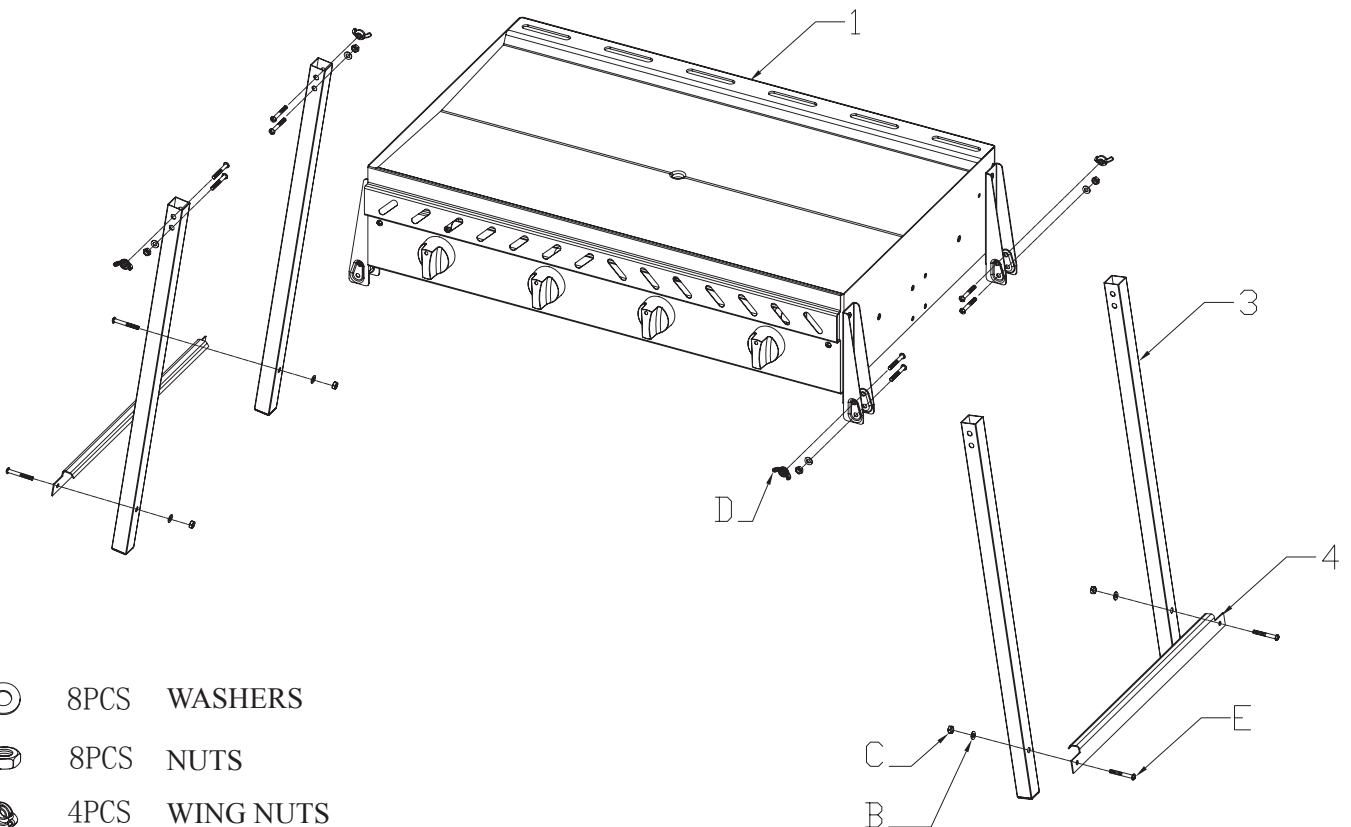

B  8PCS WASHERS

C  8PCS NUTS

D  4PCS WING NUTS

E  12PCS LONG SCREWS

## Step 3

Attach the handles from underneath using medium screws (F) and washer (B).

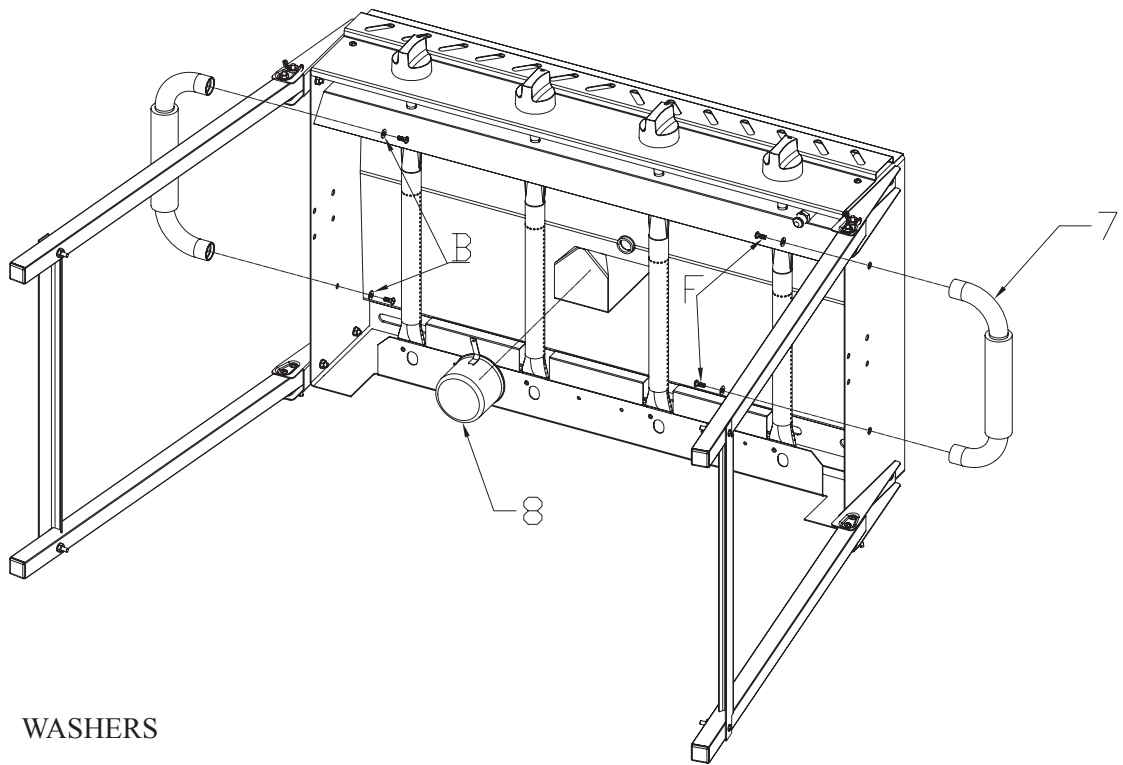

B  4PCS WASHERS

F  4PCS MEDIUM SCREWS

## Step 4

Attach the gas cylinder hook (5) and heat insulation panel (6) at the same time using short screws (A), four of the nuts (closest to the heat insulation panel) are pre-installed for your convenience.

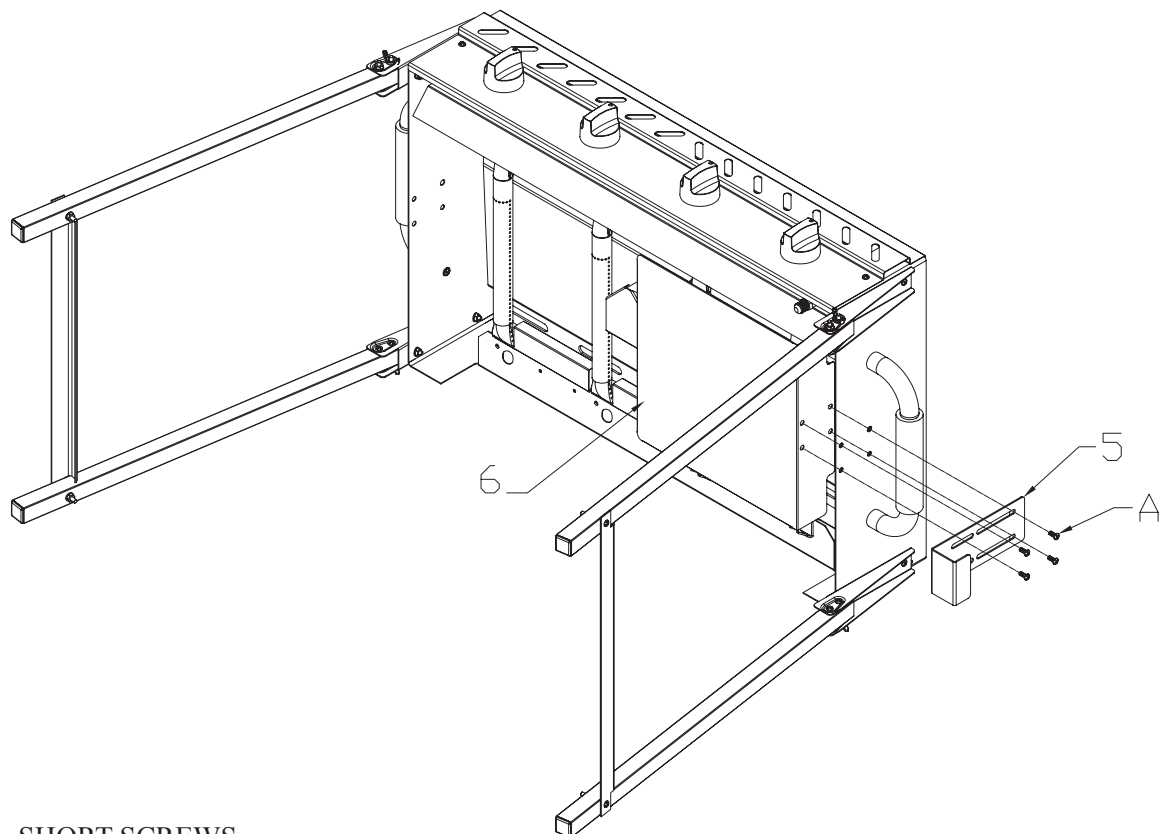

A  4PCS SHORT SCREWS

## Step 5

Hang the grease cup onto its hook underneath the two middle burners.  
Full assembly.

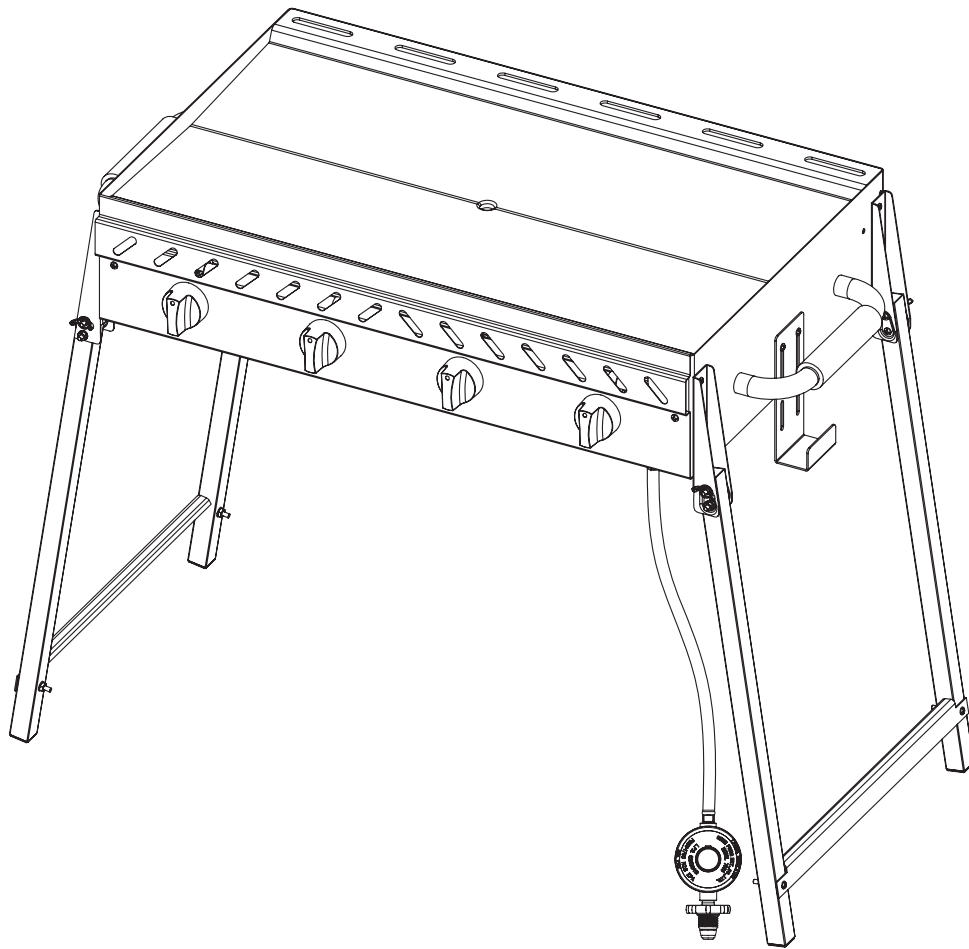



# SETTING UP THE BARBEQUE

**THIS APPLIANCE SHALL ONLY BE USED IN AN ABOVE GROUND OPEN AIR SITUATION WITH NATURAL VENTILATION, WITHOUT STAGNANT AREAS, WHERE GAS LEAKAGE AND PRODUCTS OF COMBUSTION ARE RAPIDLY DISPERSED BY WIND AND NATURAL CONVECTION**

## 1. POSITIONING

- Please make sure that the barbeque is NOT positioned underneath any combustible material or surface.
- There MUST be a clearance of at least 250mm from the sides of the barbeque to any combustible materials or surfaces. There must also be a clearance of at least 1500mm above the cooking surfaces to any combustible surface, and 500mm clearance at the back.
- Flammable materials of any description MUST be kept well away from the barbeque.
- The barbeque must be positioned such that the gas cylinder is kept away from direct sunlight.
- The barbeque must be positioned to avoid walkways, gangways and general pedestrian access.
- The nature of a barbeque is such that many of the surfaces are hot to touch, the positioning of the barbeque should take into consideration the possibility of accidental hand or body contact.

**Any enclosure in which the appliance is used shall comply with one of the following:**

- An enclosure with walls on all sides, but at least one permanent opening at ground level and no overhead cover.  
SEE EXAMPLE 1
- Within a partial enclosure that includes an overhead cover and no more than two walls.  
SEE EXAMPLE 2 & 3
- Within a partial enclosure that includes an overhead cover and more than two walls, the following shall apply-
  - at least 25% of the total wall area is completely open; and
  - at least 30% of the remaining wall area is open and unrestricted  
SEE EXAMPLE 4 & 5
- In the case of balconies, at least 20% of the total of the side, back and front wall areas shall be and remain open and unrestricted

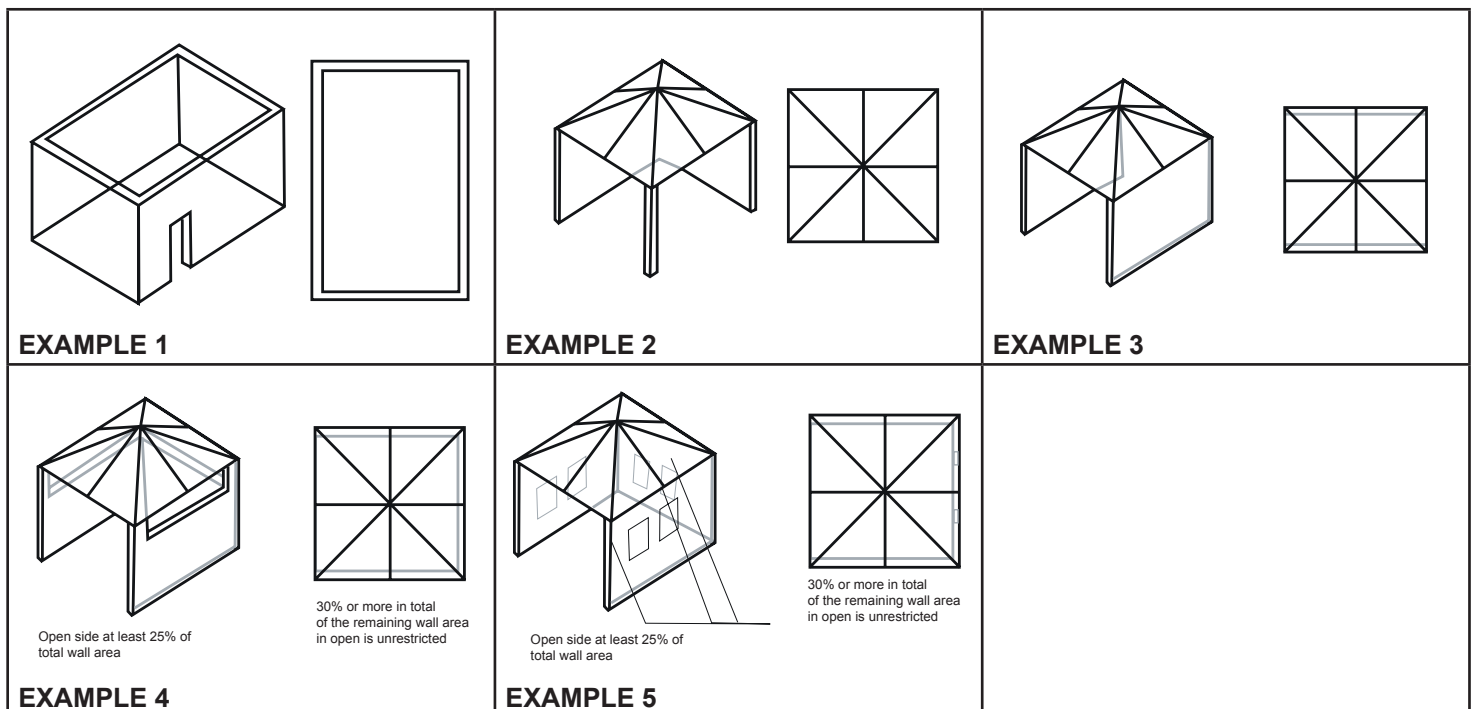

## 2. PRECAUTIONS

### DO NOT OBSTRUCT ANY AIRFLOW PATH OR VENTILATION PATHS OF THE BARBEQUE

- Do not obstruct any ventilation ports on the body of the hood of the barbeque.
- The gas cylinder must be securely placed on the gas cylinder hook as supplied.
- It is important that the gas cylinder is not positioned under the barbeque when in operation.
- The gas cylinder must be kept out of direct sunlight and away from any heat sources.
- During a gas cylinder swap or re-fill ensure that all control knobs are in the '**OFF**' position and there are no naked flames on close proximity.
- Gas hoses must **NOT** be twisted kinked or under any form of tension, the gas hoses should hang freely with no bends, folds, or kinks.
- No part of the flexible hose should come into contact with any part of the barbeque that will become hot during operation.
- A regular inspection of the hose should be made to ensure that it is not cracking, breaking cutting or deteriorating in any other way.
- Any damage to the hose requires an immediate replacement from your local agent or gas expert.

## 3. GAS Cylinder CONNECTION

### DO NOT ATTEMPT TO CONNECT THE GAS CYLINDER TO THE BARBEQUE BEFORE CHECKING AS DESCRIBED IN POINT 3. GAS SIDE BURNER CONNECTION'

- Check that all the control knobs are in the '**OFF**' position before any attempt is made to connect the regulator to the gas cylinder.
- Double check that the gas cylinder valve is securely in the 'off' position before attempting to connect the regulator to the gas cylinder.
- Make the connection of the regulator to the gas cylinder it is important to note that this connection is a '**LEFT HAND THREAD**'. A left hand thread is tightened in an '**ANTI-CLOCKWISE DIRECTION**'.
- Should there be any concern in making the correct regulator connection please contact the customer service centre.

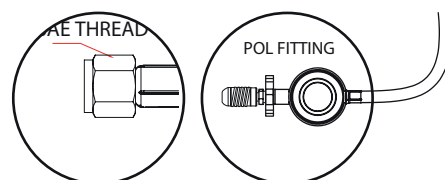

## 4. PRECAUTIONARY LEAK TEST

### LEAK TESTS MUST BE CARRIED OUT IN A WELL VENTILATED AREA

- Confirm all control knobs are in the '**OFF**' position.
- Open the gas control valve on the cylinder or regulator.
- To check for gas leaks a solution of soapy water is required (50% water and 50% soap)

### NEVER USE AN OPEN FLAME TO CARRY OUT A GAS LEAK TEST

- The gas piping system **MUST** be checked for leaks by brushing the soapy water solution across each joint including valve connections, hose connections, wok connections and regulator connections
- If bubbles appear across any joint or connection there is a leak:
  - Immediately turn the gas valve '**OFF**'.
  - Check and retighten all gas connections and joints.
  - Repeat from start of section **4. PRECAUTIONARY LEAK TEST**.
  - If the leak has been corrected then the barbeque can be used.
  - If the leak has not been fixed **DO NOT USE YOUR Barbeque** contact your service agent as listed on the warranty card for assistance.

# OPERATING YOUR BARBEQUE

## 1. WARNINGS:

- Before using the barbeque please ensure you have read and understood the entire instructions manual.

## 2. PRIOR TO COOKING:

- It is advisable to wash the cooking surface with soapy water, then apply a light coating of cooking oil before starting to cook.
- When you are lighting your barbeque for the first time, first read step 3 “STARTING THE BARBEQUE”. Turn the burners to the “LO” position and leave then running for 15 minutes. Your barbeque is now seasoned and ready for first use.
- Check that the grease cup is empty before every barbeque. Never handle the grease cup until it had completely cooled.

**Note: It is quite normal for the paint colours on the grill and hot plates to change during the first few cooking sessions.**

## 3. STARTING THE BARBEQUE:

- Ensure that all the controls are in the “**OFF**” position before attempting to light the barbeque.
- Turn on the gas supply at the gas cylinder.
- Select burner to light. Push and turn the selected control knob to “HI” (automation ignition).
- If ignition does not occur within 5 seconds, turn burner control knob to “OFF”. Wait 5 minutes and repeat the lighting procedure.

## 4 MANUAL LIGHTING:

- Light a 90mm barbeque match or a lighting gun and hold adjacent to the burner underneath the right end of the barbeque.
- Ensure the match remains lit then turn the right hand control knob to the “HI” position, the burner will light from the match.
- Once the burner is lit, repeat the process for the remaining burners.
- Each burner can be adjusted to a low heat setting by turning the control knob to the “LO” position.

**DO NOT TURN A CONTROL KNOB ON UNTIL A LIGHTED MATCH IS INSERTED UNDER THE BARBEQUE**

## 4. AFTER COOKING

- Ensure ALL control knobs are turned “**OFF**” by turning them fully clockwise.
- Once the burners have extinguished turn the gas off at the gas cylinder.
- The barbeque should then be stored in accordance with the storage guidelines in this manual.
- See cleaning instructions on the following page.

# **CARE & MAINTENANCE**

**BEFORE ANY CARE AND MAINTENANCE IS ATTEMPTED PLEASE ENSURE THAT THE BARBEQUE CONTROLS ARE IN THE 'OFF' POSITION AND THAT ALL SURFACES HAVE BEEN GIVEN SUFFICIENT TIME TO COOL DOWN.**

Please note the following when maintaining and caring for your barbeque:

- Cleaning your barbeque regularly will help to keep a pristine look.
- Throwing cold water over any hot surface of the barbeque is NOT recommended and is dangerous.
- Avoid handling and touching hot parts of the barbeque.
- As a good practice, your barbeque should be covered when left unused for long periods especially during the long winter breaks.

## **1. CLEANING THE HOT-PLATE**

After you have finished cooking it is best to clean the cooking surface while it is still warm. Scrape off all excess food using a stiff plastic spatula or paper towel secured with tongs so that you don't burn yourself. DO NOT use metal scraping tools on this hot plate as you will scratch the surface and leave the metal prone to rusting. There is little point in cleaning your cooking surfaces until they sparkle because they'll be black again after your next barbeque. Just remove the excess lumps of food, and ensure a film of oil remains on the plate to protect the cooking surfaces against rust. You should also spray a light film of cooking oil on the plate for additional protection.

## **2. CARE OF THE BURNERS**

- Normal use and the burn off should ensure that any excess food and juices are burnt off and this will help to keep the burners clean.
- The burners should be checked and cleaned yearly. It is important to check that the burner holes are free of debris and insects.
- Blockages and debris should be carefully removed using a pipe cleaner.
- Ensure that when the burners are replaced they are positioned correctly over the control valves, care must be taken not to damage the valves.

## **3. CARE OF THE BARBEQUE BODY**

- Regular care and maintenance of the barbeque body will significantly increase its life and long term appearance.
- Excess grease and fat can be removed with a soft scraper.
- It is not necessary to remove all the grease from the body.
- If required painted surfaces of the barbeque body can be cleaned by using hot soapy water and a soft bristled brush and cloth.
- Care must be taken not to immerse the gas controls (manifold and injectors) in water.
- When re-assembling the barbeque after cleaning it is important to check that the barbeque functions correctly.

## **4. MAINTENANCE OF FIXINGS**

- Over time and with regular use the fixing screws and nuts may start to become loose, a regular check of all fixings is recommended.

## **5. STORAGE**

- To ensure maximum life from your barbeque it should always be stored in a cool dry place.
- During long periods of storage the burners should be covered with aluminium foils to prevent debris and insects from blocking the burner holes.
- If you choose to store the main barbeque inside the gas cylinder must be disconnected and stored outside under the following conditions:
  - o Always store the gas cylinder outside in a well ventilated area
  - o Ensure that the gas cylinder is not stored in direct sunlight or close to heat sources and other dangerous appliances.
  - o Keep the gas cylinder out of reach of children.

# TROUBLESHOOTING GUIDE

Problem	Potential Cause	Corrective Action
Cannot light burners	Gas cylinder is empty	Check and refill/exchange gas cylinder
	Regulator is faulty	Check and replace if required
	Blocked burner	Check and clean all burner holes
	Blocked gas jets	Check and clean gas jets
	Blocked gas hose	Check and clean gas hose
Burners have a low flame or flashback	Gas cylinder maybe too small	Change to a larger cylinder
	Blocked burner	Check and clean all burner holes
	Blocked gas jets	Check and clean gas jets
	Blocked gas hose	Check and clean gas hose
	High winds	Move barbeque to a sheltered position

## SPARE PART LIST

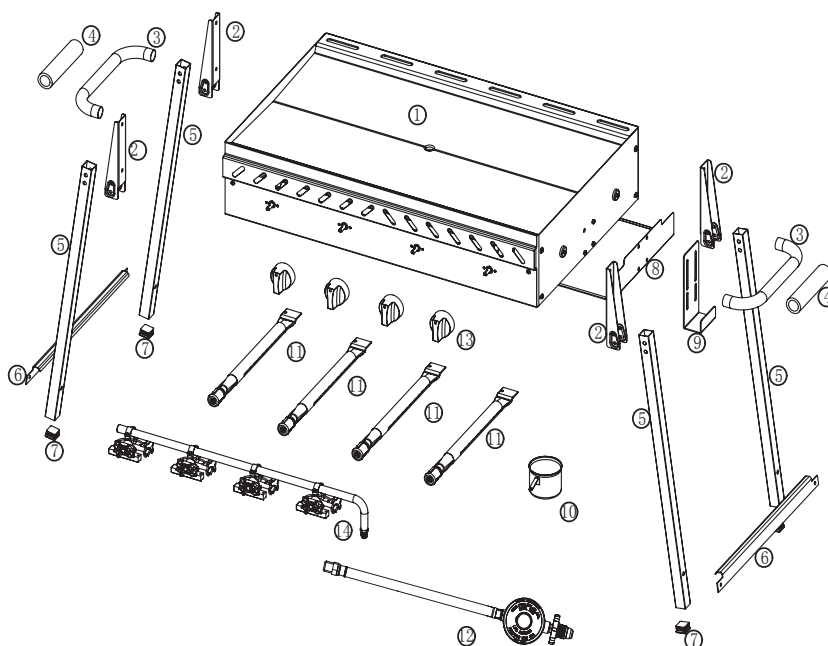

NO	GLG Codes	Description	Barcode	Qty in BBQ
1	G4DLK-S020100	FIREBOX ASSEMBLY	9311715241505	1
2	G4DLK-A0208	LEG SUPPORT BRACKET	9311715242502	4
3	G4DLK-A020300	HANDLE	9311715242526	2
4	G4DLK-A0211	HANDLE COVER	9311715243387	2
5	G4DLK-A0301	LEG	9311715243394	4
6	G4DLK-A0303	LEG CROSS BRACE	9311715243431	2
7	G4DLK-A0302	FOOT	9311715250965	4
8	G4DLK-A0207	HEAT INSULATION PANEL	9311715252075	1
9	G4DLK-A0210	GAS CYLINDER HOOK	9311715252235	1
10	G4DLK-A0209	GREASE CUP	9311715252334	1
11	G4DLK-B0203	BURNER ASSEM	9311715252341	4
12	G4DLK-B021000	REGULATOR	9311715252372	1
13	G4DLK-N0204	KNOB	9311715252402	4
14	G4DLK-S0203	MAIN VALVE	9311715252457	1
15	G4DLK-BP	BOLT PACK	9311715252624	1
16	G4DLK-S0202	CONTROL PANEL	9311715252648	1

# TECHNICAL SPECIFICATIONS

<b>Model</b>	BGW4NH007S
<b>Gas Type</b>	PROPANE ONLY
<b>Burner Injector Size</b>	1.0mm
<b>Burner Gas Consumption</b>	12.4 MJHr
<b>Burner Gas Pressure</b>	2.75 Kpa
<b>Total Gas Consumption</b>	49.6 MJHr
<b>Approval Number</b>	GMK 10011
<b>Barbeque Dimensions (LxWxH)</b>	537mm x 1046mm x 794mm
<b>Air is admitted from the ventilation holes at the back of firebox and the open area under the burner. Please ensure all these locations are not obstructed by anything</b>	

## More Information?

Need more information or assistance in anyway? You can call your nearest Barbeques Galore store where barbeque experts will be happy to help you. Just phone 1300 301 392 for your nearest store.

Or visit our website at

[www.barbequesgalore.com.au](http://www.barbequesgalore.com.au)

GLG AUSTRALIA PTY LTD (ACN 001 185 002).  
Building A2, Campus Business Park, 350-374  
Parramatta Road, Homebush, NSW 2140  
Phone 02 9735 4111