

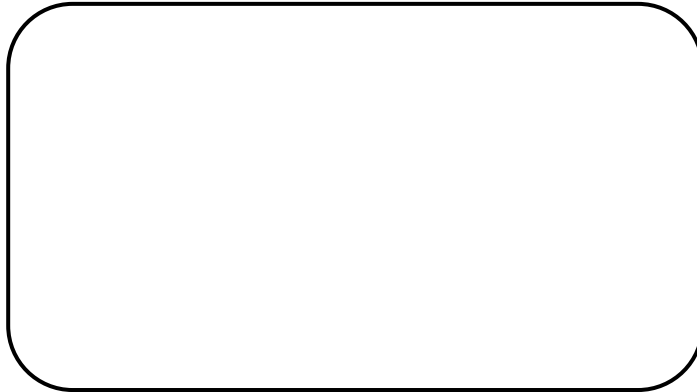

Translation of
Original User Manual

Local distributor & service partner:



Manufactured by:

GMV A/S
Industriparken 1
DK-7182 Bredsten
Denmark

Tel.: +45 7573 8247

www.gmvas.dk

Important!

- **Read these instructions carefully before use.**
- **Familiarize yourself with the running and lifting characteristics of the window robot, and**
- **how it behaves, before you start working with it, in order to be able to use it safely, securely and effectively.**
- **Be aware that you, the user, are responsible for the correct use of the window robot without endangering other people or property.**

Index

Overview and Safety

- 4 Description
- 5 Safety Instructions
- 6 Operation and safety
- 8 Safety test (before starting)

Use of Winlet 575

- 8 Driving
- 9 Lifting and handling

Service/maintenance

- 12 Storage and lifting of Winlet 575
- 13 Lifting points
- 14 Servicing
- 14 Troubleshooting
- 14 Charging the batteries
- 15 Service/maintenance
- 17 Specifications
- 18 CE – EU declaration of conformity

Dear Customer

Thank you for choosing a GMV A/S product. We have more than 25 years of experience in the construction and manufacturing industry as well as other industry. We develop, produce and sell equipment for materials handling designed for industrial use.

For further information, see www.gmvas.dk

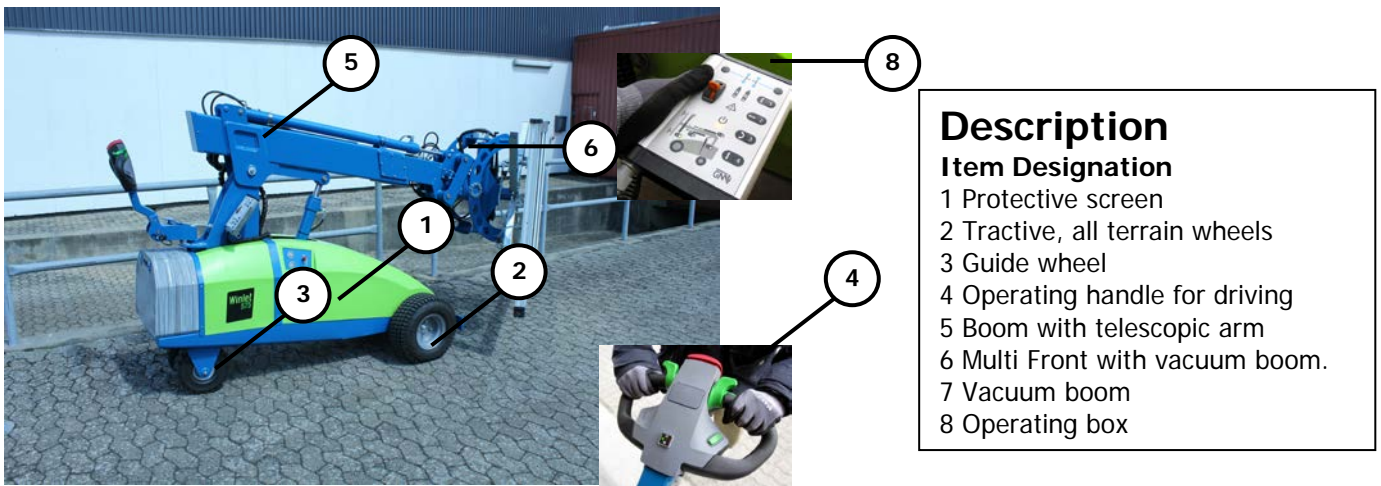

Description

Winlet 575 is a battery-operated window robot with a lifting capacity of 575 kg. The machine is made by GMV A/S to facilitate conveying and mounting of window elements or similar sealed items. Winlet 575 can also be supplied with other specially made lifting and handling fixtures to enable conveying and handling of other types of heavy loads. Winlet 575 is driven by the machine's front, terrain-friendly wheels and has an advanced, electro-hydraulic system for handling the items to be lifted.

The machine is supplied with an integrated vacuum system as standard. Please contact us concerning your conveying needs for items requiring specially made lifting and handling fixtures.

Safety instructions

General

- The window robot must be used as described in these instructions and in accordance with the general safety regulations applicable in the workplace and in the country where the Winlet 575 is used.
- Always wear steel-capped safety footwear when working with the Winlet 575. Depending on the workplace and the type of load, a helmet and protective gloves may also be required.
- To prevent unauthorised personnel from using the window robot, never leave it with the key in the ignition.
- Never leave the Window Robot on an inclined surface. The truck may begin to roll even though it is equipped with a parking brake.
- Before use, check that the Winlet 575 is not damaged in any way that could impair safety.
- Never use the Winlet 575 when the battery indicator is lit up red, as this could ruin the battery. Instead, charge as described elsewhere in this manual.
- Never use or store the Winlet 575 outdoors in wet weather. The machine is designed for use in temperatures ranging from -10 °C to +40 °C.

Driving

- The user must be aware of the surroundings when using the window robot, and must allow a generous safety margin in case unexpected situations arise.
- Plan your path of travel and make sure it is clear and negotiable. Avoid surfaces where there is a risk that the window robot could overturn or slide. Exercise great care at corners and junctions.
- To avoid danger of overturning, the window robot's right-hand wheel set must always be at the same level as the left-hand wheel set of the truck.
- Always drive with the load lowered.
- Be aware that high speed in constricted spaces represents a major safety risk.
- Never make sharp turns at high speed. Turning reduces the stability of the window robot.
- Only use the Winlet 575 in locations with satisfactory lighting.
- Always keep both hands on the manoeuvring handle when manoeuvring.

Vacuum

- The Winlet 575 is designed to transport and mount window elements and other sealed elements as well as other materials using the specialist equipment supplied.
- Always lift the item at its centre of gravity and in the centre; otherwise, the item may tear free from the suction plates.
- Only activate the vacuum function when the suction cups are placed on a sealed, dry, clean surface. Any other use can damage the vacuum system.

Lifting and handling

- The Winlet 575 has moving parts which could give rise to a risk of crushing; accordingly, when lifting and lowering loads, it is important to ensure there is no one in the area of risk where crushing could occur.
- Never lift an item until a sufficient vacuum has been achieved. If the vacuum level diminishes, put down the item immediately.
- Exercise great care when lifting and handling lifted items, as sudden movements or jolts can cause the item to break away from the suction cups.
- Be particularly aware of the capacity limitations of the machine (as stated elsewhere in this manual). The machine's capacity is reduced when items are handled with the lifting arm extended or when lifting at the side of the machine. Pay attention to the warning signals from the machine when maximum capacity is reached.

Operation and safety

Safety functions when driving

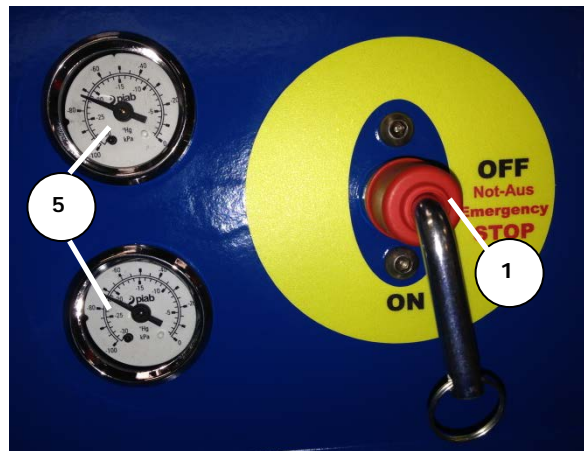
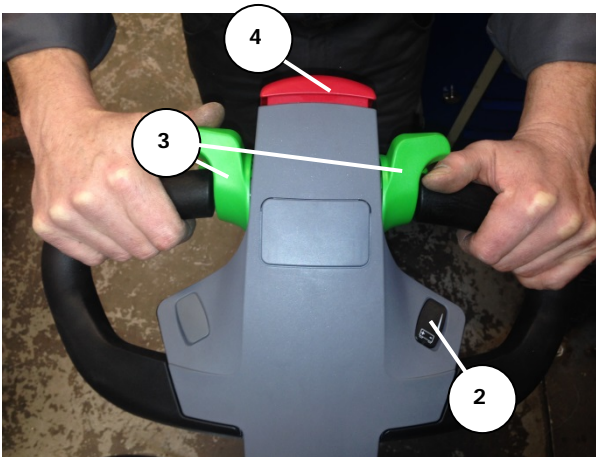

Description

Item. Designation

- 1 On/Off-switch - key contact / Emergency Stop
- 2 Battery indicator
- 3 Drive direction / speed regulator
- 4 Safety cut-out switch (stomach switch)
- 5 Vacuum gauges

Winlet 575 is equipped with a standard type of maneuvering handle. This incorporates a number of safety functions.

- Safety switch ("stomach switch"); when activated, stops the movement of the window robot. Once the window robot has stopped, it moves in the opposite direction to avoid risk of crushing.
- Dead-man function, which ensures all functions stop if the operating handle is taken to the top position.

Winlet 575 is provided with a power switch which has a removable key. The power switch also functions as emergency stop. As soon as the key is turned in the "OFF" position the power supply to the machine's functions turns off. The key switch is spring-loaded so that upon activation of the emergency stop, the key switch remains in the OFF position. This will bring both hydraulic cylinders and drive motor to an immediate stop. By activating the emergency stop, there ALWAYS remains suction in the suction cups - however, one must be especially alert when the vacuum pump for an emergency also loose power. Both vacuum circuits are provided with individual vacuum tanks to ensure sufficient vacuum for at least five minutes if the system is free of any leaks. The current level of vacuum in the suction cups can always be monitored on the 2 vacuum gauges. When the vacuum level is 60% or more, the machine has full lifting capacity.

Safety functions when lifting and handling

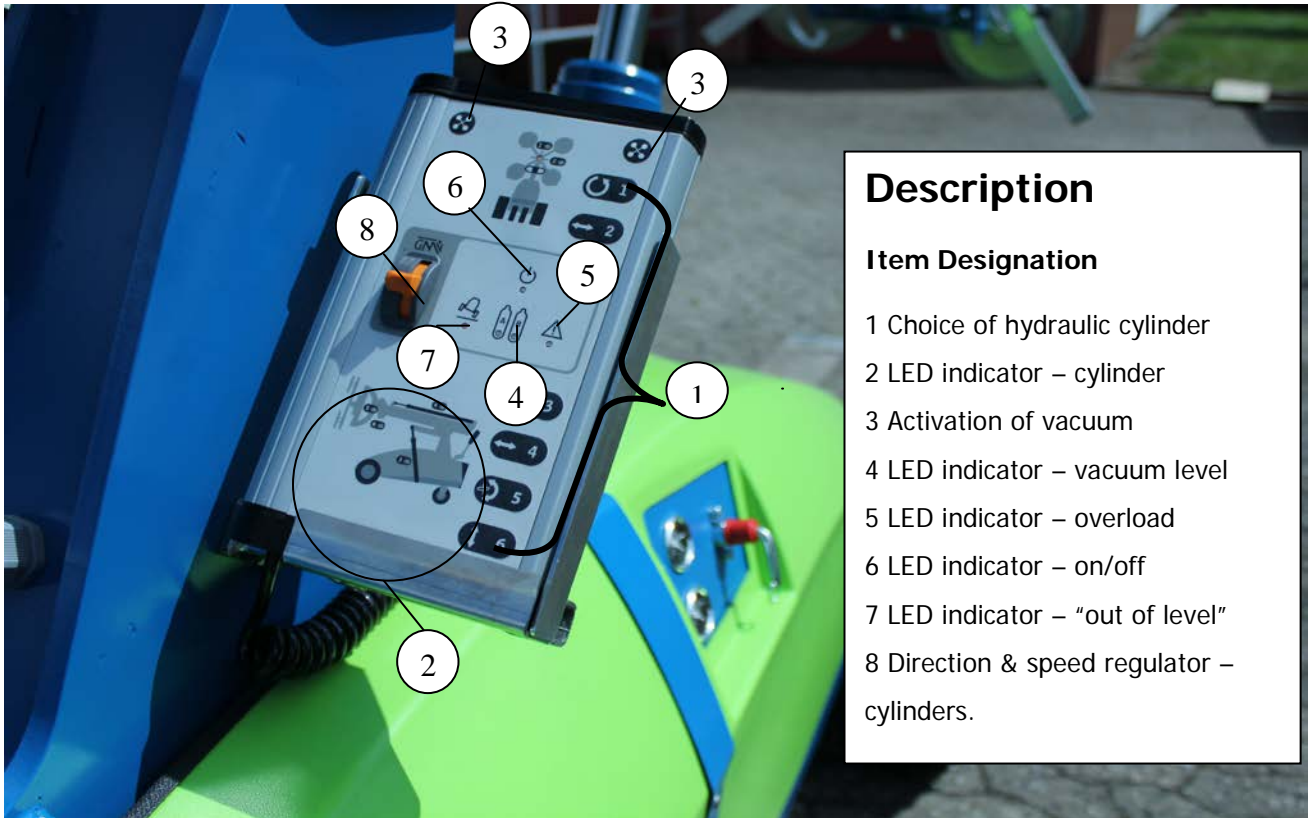

The Winlet 575 is equipped with an operating panel from which all vacuum and hydraulic functions are controlled. The integrated safety functions are:

- 2-button safety operation of the machine's vacuum system. Both buttons must be activated at once either to pick up a load or to put down a load.
- The double-circuit vacuum system of the machine is monitored by two vacuumsensors which, via LED lamps, give a signal if the vacuum is insufficient for safe lifting.
- LED lamps show which cylinder is active.
- LED Lamps show “out of level” status.
- Intelligent overload protection shows when the machine reaches the limits of its capacity.

Note that lifting loads at the side of the machine impairs the stability of the machine, and that these risks are **not fully** monitored by the machine's overload monitoring system. Always use the outrigger when handling loads at the side of the machine. **Always exercise particular care when handling loads at the side of the machine and, as the operator, always consider whether safety is taken care of and ensure that the capacity of the machine is not exceeded.**

Safety test (before driving or lifting)

The window robot must be safety-tested daily before use. This test must be carried out without load.

Important! If any of the items do not pass the safety test, the machine must not be used!

- Carry out an inspection to ensure that the mechanical parts of the window robots are not worn or damaged to such an extent that the safety of the machine is compromised.
- Hold the operating arm down in the normal position and drive the Winlet 575 back and forth. Move the operating arm, without load, to the top position and try driving the machine forwards and backwards. This should not be possible.
- Drive the Winlet 575 towards you and depress the safety switch on the handle. The machine must stop immediately and move away in the opposite direction.
Note! This test must be carried out in an open space where there is no risk of your being crushed between the window robot and any objects or walls.
- Drive the Winlet 575 away from you and release the operating arm. The spring pressure in the operating arm must take the operating arm to the no-load top position, after which the machine must stop at approximately 0.5 m and the driving function must not be usable until the operating handle is back down in the operating position.
- Check the window robot vacuum system for leaks:
Leak test process
Place all suction cups on a level, dry and airtight surface (e.g. a window). Start the Winlet 575 at the on/off button and wait until the red lamps go out on the operating panel. Now activate the vacuum by engaging both buttons on the operating panel at the same time. Both vacuum meters now show the current vacuum in each vacuum circuit. Once a full vacuum has been achieved in both circuits (a vacuum level of approximately 75%), turn the Winlet 575 off again at the on/off button. Now look at both vacuum meters; the vacuum level must not drop more than 10% in the course of 5 minutes.
If the vacuum loss is greater than 10% in 5 minutes, check all hose connections and tighten any connections as required. Check the condition of the suction plates. The seals must not show any signs of scratches.

Driving

Forward/reverse

The speed is steeplessly controlled, and is adjusted by turning the regulator to a greater or lesser degree.

- Keep the operating arm in the normal position and then turn the drive direction and speed regulator to the desired position. Release the regulator to stop the machine.

Braking

- When the speed regulator is released, the window robot brakes and stops. Releasing the speed regulator slowly can produce gentle braking. This is the normal way of braking.
- When the operating arm is released, the transport truck stops suddenly and the parking brake kicks in. This function is only intended to be used in a situation when the user wants to stop the truck as quickly as possible.
Note! To maximise the service life of the Winlet 575, it is recommended to release the speed regulator first, and only to release the operating arm once the machine has stopped.
- When driving with lifted items, all lifting cylinders must always be in the inner position.

Manual pull/push of the machine in the event of breakdown of the electrical drive

The electrically-powered drive shaft, which drives the front wheel-set of the machine, can be disengaged in the brake. This is useful in the event of a breakdown of the machine.

- Remove the protective screen of the machine
- Press the button marked "PUSH" on the main print board.



Lifting and handling

Vacuum lift

The Winlet 575 is equipped with an integrated **double-circuit** vacuum system with intelligent vacuum monitoring, which gives an alarm to indicate insufficient vacuum level. The vacuum pump is equipped with Power Save, to save the batteries when there is sufficient vacuum.

Using the vacuum function:

Start the Winlet 575 with the on/off button. Press both buttons for the vacuum function on the operating panel and wait a moment until both red LED lamps go out. During this time, a vacuum of at least 60% has been created in the vacuum system.

Picking up a load.

Place the suction plates on the item. Press both buttons at the same time on the operating panel. The item has been attached by suction once both vacuum meters show more than 60% and the red lamps have gone out; only then can lifting and transporting proceed!

! Make sure the vacuum level is above 60% in both circuits.

! Always lift the item at its centre of gravity and in the centre; otherwise, the item may tear free from the suction plates.

Conveying of load.

After attaching the item by suction, move the item to the desired position by driving the Winlet 575.

Take note of the following points:

- ! The working area must be clear of any people and/or objects.
Danger of injury by collision!
- ! Never step under a hovering load!
Danger of falling load!
- ! If the vacuum level in only one of the 2 vacuum circuits drops below 60%, put the load down **immediately** !
- ! If one of the red lamps lights up, put the load down **immediately** !

Putting down the load.

Convey the lifted item to the desired place, and put it down. When the load has been placed securely, press both buttons on the operating panel simultaneously. Now the air can flow to the suction plates, and the load will be released immediately. Now a new work process can be undertaken.

- ! Make sure the load is placed securely and that it cannot slide after being put down!

Handling of load (use of hydraulic cylinders)

The Winlet 575 is equipped with an electro-hydraulic system which makes it possible to move the lifting arm and front of the machine in 6 different directions:

1. Rotation
2. Side shift
3. Main cylinder, which positions the item roughly in the vertical position.
4. Telescopic cylinder, which moves the item forward along the longitudinal axis of the machine.
5. Tilting cylinder, which moves items from a horizontal floor – to a horizontal
6. Fine-adjustment cylinder, which moves the item in a 100% vertical line.

The front of Winlet 575 can also be moved on the side of the machine (right side) for easy access via door openings carrying glass elements.

Use of hydraulic cylinders

Press the desired cylinder on the operating panel. An LED lamp will now show the selected cylinder. The cylinder can then be moved in the desired direction at the desired speed by engaging the direction and speed regulator.

Take note of the following points:

- ! The working area must be clear of any people and/or objects.
Danger of injury by collision!
- ! Never step under a hovering load!
Danger from falling load!
- ! If the vacuum level in only one of the 2 vacuum circuits drops below 60%, put the load down **immediately** !
- ! If one of the red lamps lights up, put the load down **immediately** !

“Gyro-function”

Winlet 575 is equipped (optional) with a sensor that measures the vertical position of the front of the machine. When the function is activated there will be an automatic adjustment of the lifted object to ensure that it will stay in the same angle when the main cylinder (cylinder 3) is used. The Gyro is activated like this:

- Press the button for cylinder 5 and keep it pressed for two seconds. The LED for cylinder 5 will now start blinking and the LED for cylinder 3 will be permanently lit. Winlet 575 will now keep the lifted object in the position it was in when activated.
- To deactivate the function, simply press cylinder 5 again until the LED stops blinking.

When using cylinder 3 with the gyro function activated, cylinder 5 will automatically adjust for the change in angle. Please note, that the Gyro is most accurate in an area of ± 45 degrees from vertical.

Note: Be aware that the capacity of the machine is reduced when using the hydraulic cylinders.

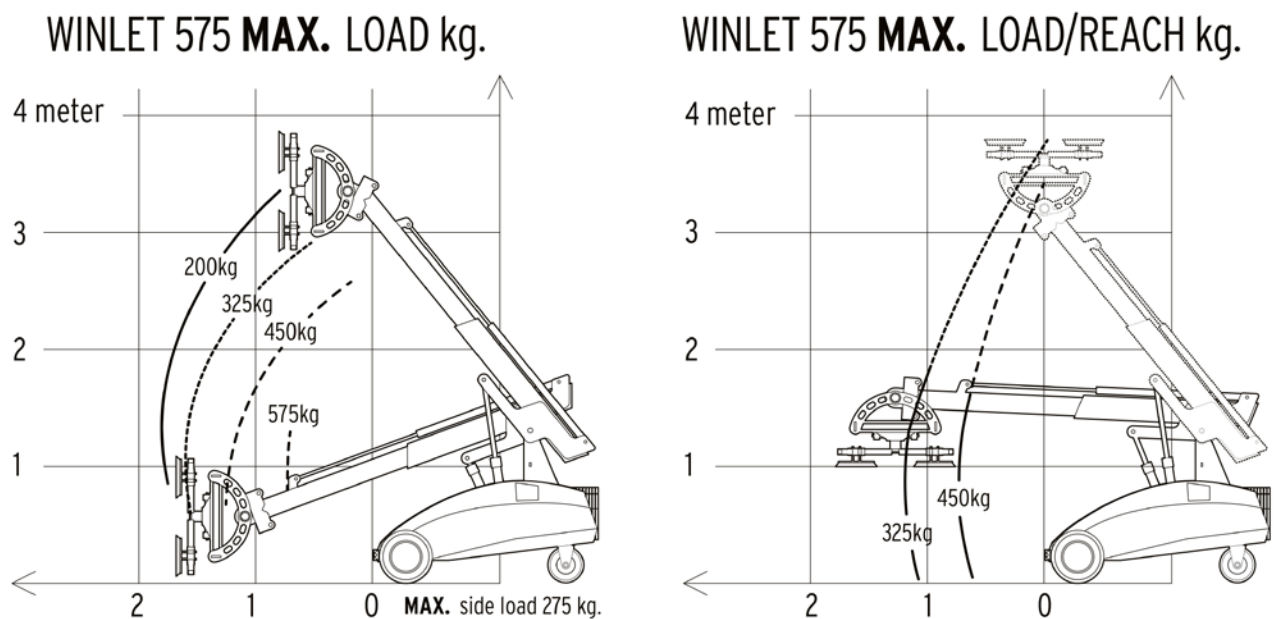

The stated values are for reference. And based on a 100% level surface.

The Winlet 575 is equipped with load monitoring whereby a red LED flashes and on the operating panel when approaching the max. capacity in a given position. At this warning, all cylinders must be retracted. If you continue running the cylinders "outwards", the warning lamp will remain on constantly and an acoustic warning signal will sound. At this point all cylinders can only be retracted.

Your machine is either equipped with an electrical load cell or an hydraulic oil pressure switch. Contact your dealer to know which type your machine is equipped with.

! It is always the operators responsibility only to use Winlet 575 within the capacity limits also in case that the electric warning system is out of function.

! Note if overload protection is with hydraulic pressure switch, it is measuring changes in pressure of the hydraulic oil in the main cylinder (cylinder 3). This means that when using the telescopic cylinder (cylinder 4) there can be situations where the warning and cut-off can be delayed. The operator should therefor pay extra attention to the machines capacity limits when using cylinder 3. To enable function of the overload warning system, the operator should always make sure that cylinder 2 has been activated before using other functions.

Using the machine on non-level terrain/driving surface impairs the stability of the machine, and that these risks are **not** fully monitored by the machine's overload monitoring system. Always use the outrigger if the machine is being used other than on level terrain/driving surface. **Always exercise particular care where the machine is being used on non-level terrain/driving surface, and, as the operator, always consider whether safety is taken care of and ensure that the capacity of the machine is not exceeded.**

Warning signal on not level ground.

If Winlet 575 is not operated on level surface (both front wheels in same level) a LED will flash and an acoustic signal will sound(only if equipped with Gyro-function)

Using the multi-movable front

The front is locked against movement to the side of the machine. If you want to turn the front to the side of the machine, you must unlock the front in top and bottom.

When the front has been brought to the desired position the latch must always be reactivated.

Storage and lifting of Winlet 575

- After use, check the level of charge in the batteries via the battery indicator, and charge as required. See below concerning instructions with regard to charging.

- Never use the Winlet 575 when the battery indicator is lit up red.

Important! Batteries stored for a prolonged period must have a maintenance charge (be fully charged), to avoid damage to the batteries.

- Turn off the window robot. To do so, turn the ignition key/press the off-button.

Important! When storing for an extended period, turn off the machine to avoid damaging the batteries. This is because there is always a certain amount of current consumption as long as the ignition is on.

- Winlet 575 may only be lifted using the three sling-attachment eyes. Always lift the truck in the horizontal position. A three-part lifting sling for the Winlet 575 can be supplied, to ensure correct, safe lifting.

Sling-attachment points at the drive wheel:



Sling-attachment point at the counterweight:

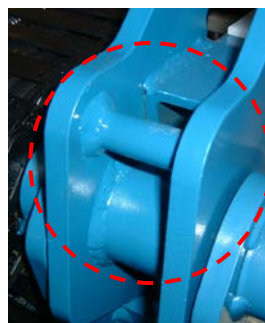

Calculations lifting points Winlet 575 (total weight 1.300 kg)

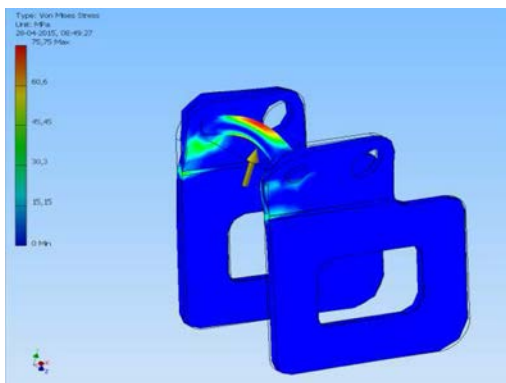
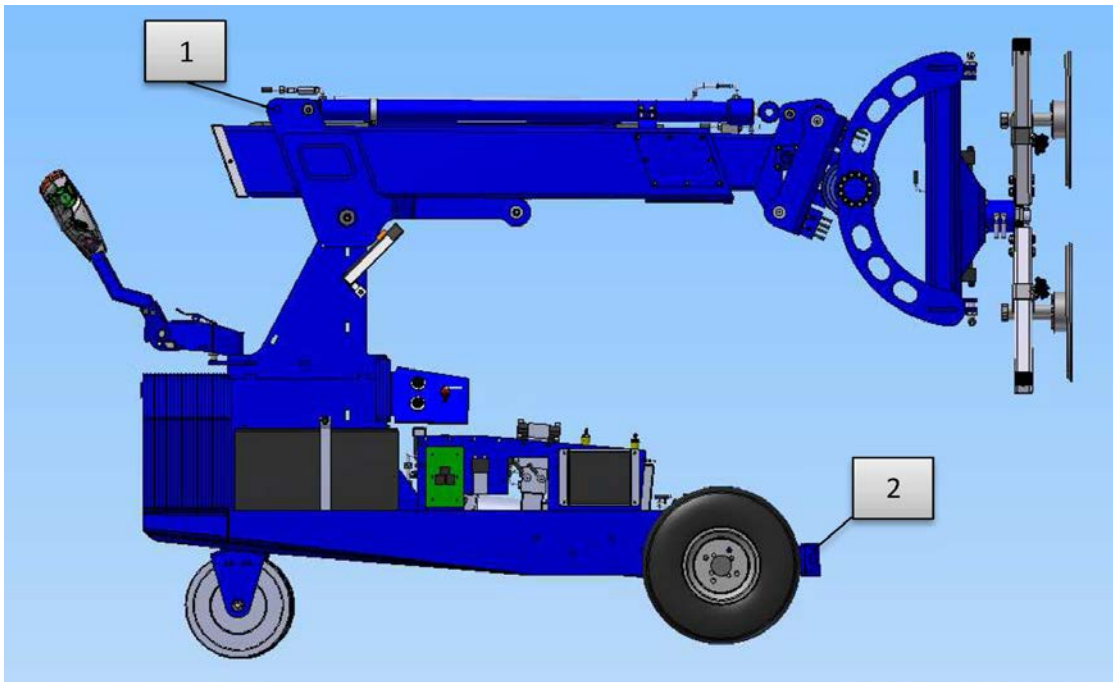

1.
 Lifting weight: 700 kg
 Max stress steel 355 = 355N/mm²
SAFETY FACTOR: 355/75,75 = 4,6

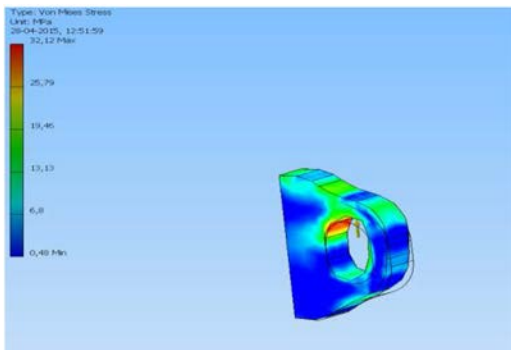

2.
 Lifting weight: 600/2 = 300 kg
 Max stress steel 355 = 355N/mm²
SAFETY FACTOR: 355/32,12 = 11

Servicing

Carry out regular checks of the window robot to ensure that it is not damaged.

Check that:

- The mechanical parts of the window robot have not become worn or damaged to such an extent that the safety or performance of the machine is compromised.
- The suction cups of the window robot have not become worn or damaged to such an extent that the safety or performance of the machine is compromised.
- The manoeuvring handle is securely seated and is not damaged.
- All functions on the manoeuvring handle are working correctly.
- The operating panel is not damaged.
- All functions on the operating panel are working correctly.
- The wheels are not damaged or worn to the point that they need replacing.
- There are no leaks from the gearbox, hydraulic pump, cylinders or batteries.
- All visible electric cables and hydraulic hoses are intact.

Troubleshooting

If the window robot does not work, check that:

- the ignition key/switch is in the correct position.
- the batteries are not flat.
- the red LED on Winlet computer is flashing (Under green cover)

Charging/batteries

General

- Never charge the Winlet 575 if damage is evident on the battery charger connection cable. This could be fatal!
- Charging must always be done at the designated site, which must be dry and well-ventilated. At this site, there must be no sparks from angle grinders, open flames or smoking, for example.
- Do not start charging the batteries immediately after use. Allow the batteries to cool first.
- Batteries stored for a prolonged period must have a maintenance charge (be fully charged), to avoid damage to the batteries.

Charging

- Always charge after use.
- Turn the machine off with the ignition key/at the off-button.
- Connect an earthed plug with voltage 230 V (110 V optional). Charging time is approximately 12 hours, if the batteries are completely empty.

Service/maintenance

General

The Winlet 575 is designed to cope with the demands and the environment extant at a construction site, but its service life and safety can be reduced considerably if the stated service/maintenance items are not complied with.

All mechanical joints must be checked at regular intervals to ensure that no components have worked loose. In general, special attention is required after the initial hours of operation when the machine is brand-new, as well as after the machine has been taken apart/any repairs.

Servicing by specialist personnel

As a minimum requirement, a full overhaul must be carried out by specialist personnel every 12 calendar months. Contact GMV A/S for further information.

Cleaning

Clean the machine regularly with a damp sponge, brush or vacuum cleaner.

Important! Do not wash the machine with running water, as this could ruin the truck components.

Lubrication

The Winlet 575 is primarily constructed using maintenance-free bearings in all moving parts. All these parts must be kept free of dirt, but lubrication is not required. This means the machine should only be lubricated with grease at joints as required:

Extension arm

The bearings in the extension arm is packed with grease at the factory. Check and top up at each main overhaul (at least every 12 calendar months), and apart from that, during normal operating conditions, no additional lubrication should be anticipated. Checking and topping up with grease should only be necessary if operation starts to feel sluggish. In such a case, always contact a qualified service technician, because this requires partial dismantling of the machine.

Bring the extension arm to minimum extension and open the back cover of the main arm. Inside is two nipples that should be used for lubrication.



Remove cover to access the grease nipples

Main Cylinder

The main cylinder has two grease nipples – one in top and one in bottom. Check and top up at each main overhaul (at least every 12 calendar months), and apart from that, during normal operating conditions, no additional lubrication should be anticipated.

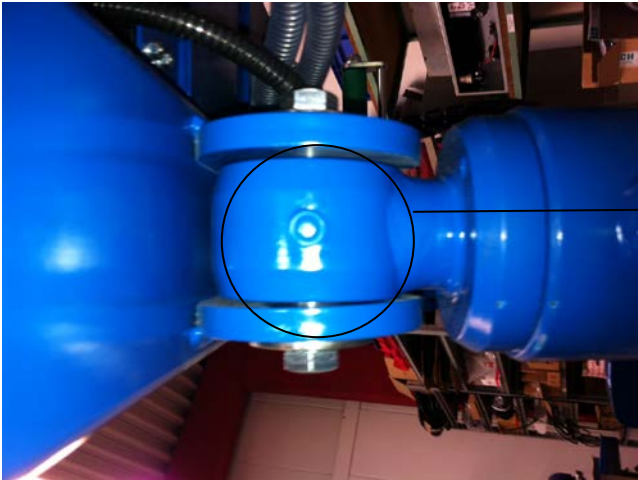

Grease main cylinder at top and bottom.

Important! Be aware that all prolonged and repeated contact with oils and lubricants constitutes a risk to health; whenever necessary, wear protective gloves and goggles when implementing the points below.

Maintenance of the hydraulic system

- Change the oil after every 1500 hours of operation or at least once a year (oil type Gulf Harmony ZF HVI 32 or similar).

Maintenance of the vacuum system

- The vacuum pump contains wearing parts. If the pump cannot achieve a vacuum level of min. 70% (-70 kPa), it must be replaced or serviced by qualified personnel.
- Do not dismantle the vacuum pump while it is under warranty – this would invalidate the warranty.
- The vacuum system is fitted with a filter. The filter is located in the machine's motor compartment, beside the two vacuum tanks. The filter must be cleaned at appropriate intervals, depending very much on how clean and particle-free the items being lifted are.
- The window robot's vacuum system must have all the hose clamps re-tightened as required.
Important! The screwed-on fittings must not be re-tightened because they are sealed with floating, self-hardening thread sealant. Re-tightening them could give rise to a risk of leakage. If they are accidentally re-tightened, the error must be rectified immediately by re-sealing the fittings.

Drive shaft lubrication/maintenance

- Do not open up the drive shaft/motor while under warranty – opening this will invalidate the warranty.
- Service the carbon brushes after every 500 hours of operation – if the length exceeds 12 mm, they should be replaced.
- Service the brake function after every 500 hours of operation – the air gap must be 0.3–0.4mm.
- Check the oil level after every 500 hours of operation.
- Service seals and re-tighten bolts after every 1000 hours of operation.
- Change the oil after every 1500 hours of operation or at least once a year (oil type SAE80W90 GL3).

Specifications:	
Max. load	575 kg
Width	890 mm
External length	1880 mm
Weight	1.025/1.300kg
Min. Extension	700 mm
Max. Extension	1.800 mm
Max. height of centre lifting yoke	3.600 mm
Lateral displacement	100 mm
Fine hoisting in tower	500 mm
Rotation	180 degrees
Suction cups	4 x ø350 mm
Motor	24 Volt
Speed	0–6 km/h
Lifting-lowering function	Electro-hydraulic
Battery	24 Volt - 2 x 150 Ah
Charging – integral charger	230V(110v)

Sound pressure level

The sound pressure level of the machine has been tested during driving with the machine's driving gear, with the machine's vacuum pump running simultaneously. The following values were ascertained:

A-weighted sound pressure level: Below 70 dB(A)

C-weighted maximum sound pressure level: Below 63 Pa (130 dB compared to 20 µ Pa).

CE – EU Declaration of conformity

Manufacturer

Company name: GMV A/S
Address: Industriparken 1
Post code: DK-7182 Bredsten
Tel.: +45 7573 8247

Responsible for the technical dossier

Authorised to prepare the technical dossier:

Jesper Faurskov
GMV A/S
Industriparken 1
DK-7182 Bredsten

hereby declares that

Machine

Designation: Winlet

Type: 575

Machine no.:

- a) conforms to the following Directive:
 - i. Machinery Directive 2006/42/EC
- b) Manufactured in accordance with the following national/international standards and technical specifications:
 - i. The Danish Working Environment Authority, "anvisninger om tekniske hjælpemidler" (instructions concerning technical aids")
 - ii. The Danish Working Environment Authority, "meddelelser om tekniske hjælpemidler" (notifications concerning technical aids")
 - iii. The Danish Working Environment Authority, "vejledninger om tekniske hjælpemidler" (guidelines concerning technical aids")
- c) Manufactured in partial accord with the following harmonized standards:
 - i. EN 13155-2003

Signature

Name: Jesper P. Faurskov

Title: Managing Director

Company: GMV A/S

Date:

Signature: -----