

Translation of the original Documentation

in accordance with EU Machinery Directive 2006/42/EC

Product: **Aluminium Quick-Assembly Gantry Crane (ASP)**
Version: **Moveable under Load**
Model: **Mini – Standard – Maxi**
Article no.: **121000 – 122000 – 123000**
Language: English
As of: 01.02.2017
Revision index: 01



Serial number

Enter the serial number of the crane here!

Please read these instructions carefully before use and retain them for further application!

The documentation should stay with the product when transferred to third parties.

This documentation is issued by:

© Feltes GmbH, Gerätebau - Gerätevertrieb

Marie-Curie-Straße 9
D-40822 Mettmann
Germany

Tel: +49 (0) 2104 8184120
Fax: +49 (0) 2104 8184129
Email: info@feltes-gmbh.de
Website: www.feltes-gmbh.de



Copyright note

Texts, images, graphics, and similar, as well as their arrangement, are subject to copyright protection and other protective legislation. The replication, change, transfer, or publication of the content of this document in part or in whole is prohibited in any form.

This document is informational, its sole purpose being to aid intended use, and does not authorise reproduction of the products concerned.

All designations contained in this document (registered trademarks like logos and business designations) are the property of Feltes GmbH, Gerätebau - Gerätevertrieb or third parties and may not be used, copied, or distributed without prior written approval.

Trademarks of third parties

In this document, trademarks of third parties may be referred to without special identification.

The article number, serial number and load capacity can be found on the identification label.

This is affixed to the carrier!

The illustrations and drawings in this document may vary slightly from the delivered product.

Please note that the load capacity must not be exceeded.

Table of Contents:

	<u>Page</u>	
1	Area of application	3
2	Equipment-specific application guidelines	3
3	Article description	4
4	Carrier load capacity / Trolley travel length	5
5	Diagram	6-7
6	Exploded diagram / Spare parts list	8-9
7	Assembly	10-12
8	Technical data	13
9	Safety hazards	13
10	Safety rules and regulations	14
11	Maintenance, checks, repairs and cleaning	14-15
12	List of hazards	15-17
13	Hazard area	18
14	Safety instructions	18-24
15	EC Declaration of Conformity	25
16	Additional documentation	26-28

1 Area of application

The aluminium quick-assembly gantry crane (ASP) is used for lifting and moving loads on even and hard-surfaced grounds.

2 Equipment-specific application guidelines

- 2.1 The aluminium carrier must be aligned horizontally and the carrier supports of the Side frames must be aligned vertically.
- 2.2 Before the ASP is used under load, all plug-in-bolts must be plugged in and (where necessary) secured with clip pins.
- 2.3 The trolley may only be used on the beam section between the two Side frames.
- 2.4 Loads which do not act in the plane which is stretched through the aluminium carrier and the carrier supports must be avoided (diagonal pulls).
- 2.5 The trolley and possibly a hoist must be removed before dismantling the ASP or the trolley must be secured against rolling.
- 2.6 When adjusting the carrier supports, the operator should grab only the handle and plug-in bolt.
- 2.7 Where wind speeds exceed 40 km/h the equipment must be dismantled or securely anchored to the ground.
- 2.8 The ASP may not be used on icy and slippery ground.
- 2.9 The operating temperature range is from -20 C° to +60 C°.

3 Article description

Aluminium Quick-Assembly Gantry Crane (ASP)

Version: Moveable under Load
Model: Mini – Standard – Maxi
Article no.: 121000 – 122000 – 123000
Load capacity: 500 – 1000 kg (depending on carrier length)

Hook-up point at trolley bolt: "see page 7"
- Total height of assembled crane: "see page 7"

Consisting of:

- 1x Side frame with plug-in support
Side frame width: "see page 7"
Height adjustment range:
 - Carrier support – Adjustment range: "see page 7" - Interval 50 mm
 - Support for rolls: 410 mm in length

- 1x Side frame with horizontal adjuster
(By using the horizontal adjuster, the usable length of the aluminium gantry crane between the Side frames becomes infinitely adjustable.
The runway length of the aluminium carrier is adjustable.)
Side frame width: "see page 7"
Height adjustment range:
 - Carrier support – Adjustment range: "see page 7" - Interval 50 mm
 - Support for rolls: 410 mm in length

- 1 x Aluminium carrier: "Length see page 13"
Carrier receptacle: one side push-in sleeve, other side cover plate

- 1x Trolley 1500 kg

Danger The use and operation of the aluminium quick-assembly gantry crane (ASP) requires proper and careful handling. Please exercise extreme caution when operating this product.

The aluminium quick-assembly gantry crane system is a highly mobile, flexible, height and length adjustable, free-standing construction.
The aluminium quick-assembly gantry crane (ASP) can be easily assembled and dismantled in just a few steps.
There are no structural changes necessary (e.g. no dowel fixation or similar measures).

Customs tariff number (statistic goods number): 84261900, weight: "see page 13"
Serial number: *You will find the serial number on the identification label which is affixed to the carrier.*

4 Carrier load capacity

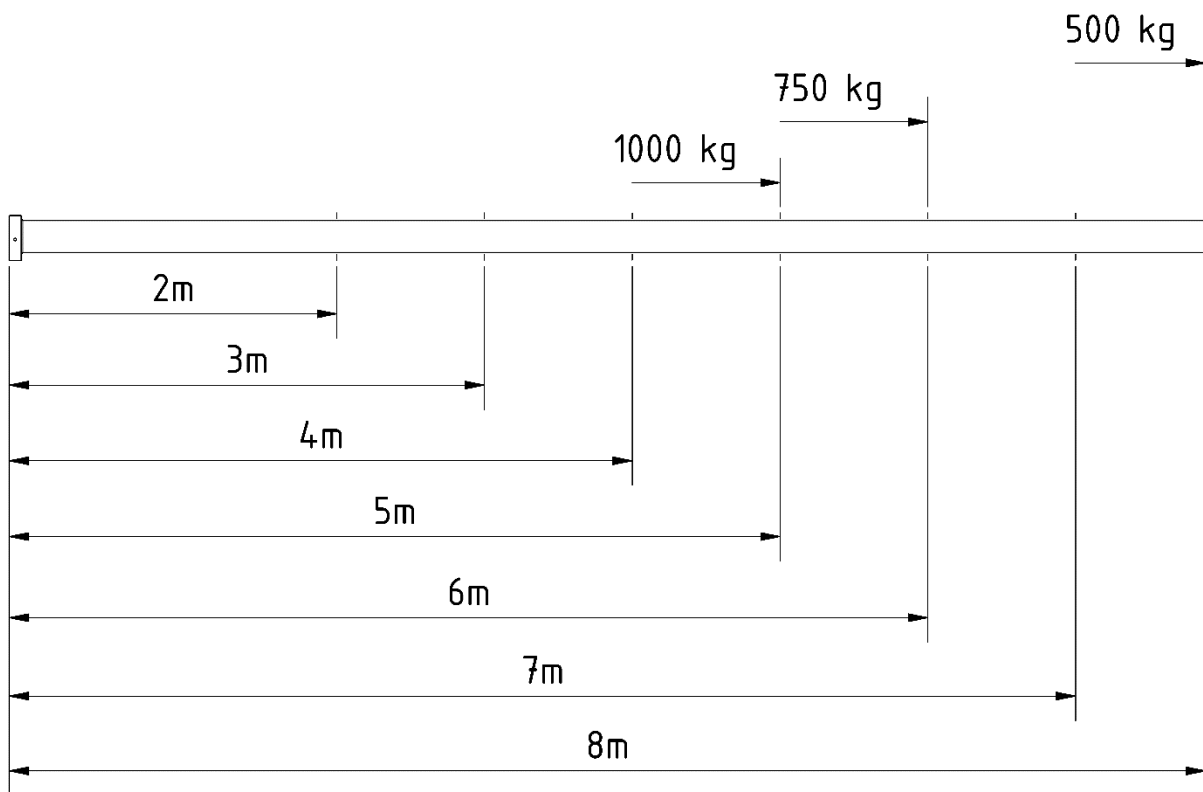

4 Trolley travel length

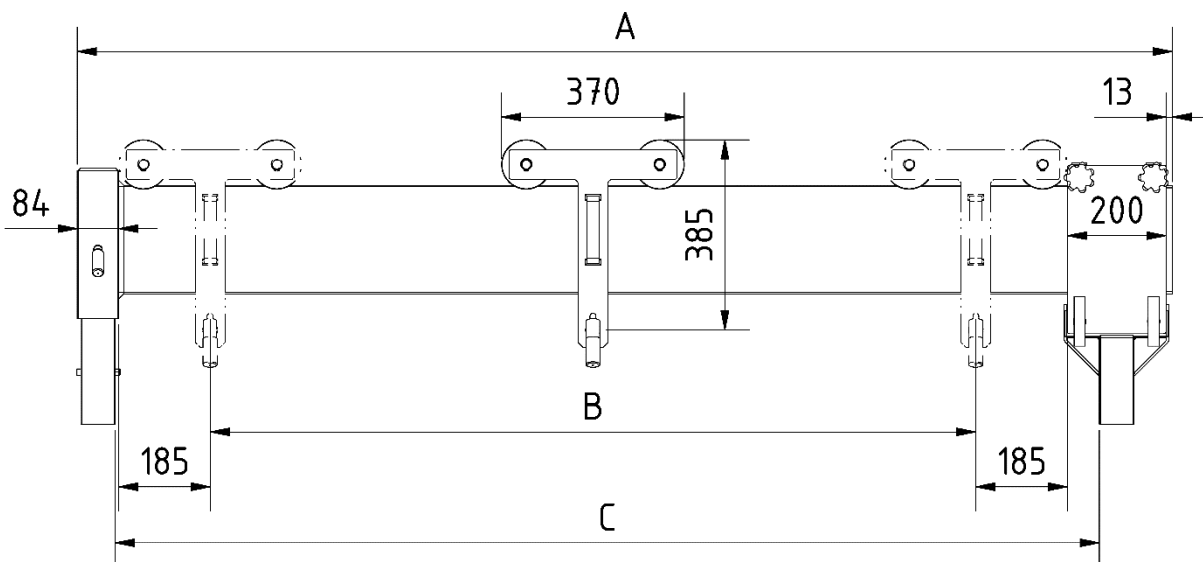

	Carrier length						
	2m	3m	4m	5m	6m	7m	8m
A	2217	3217	4217	5217	6217	7217	8097
B	1550	2550	3550	4550	5550	6550	7430
C	1992	2992	3992	4992	5992	6992	7872

5 Diagram

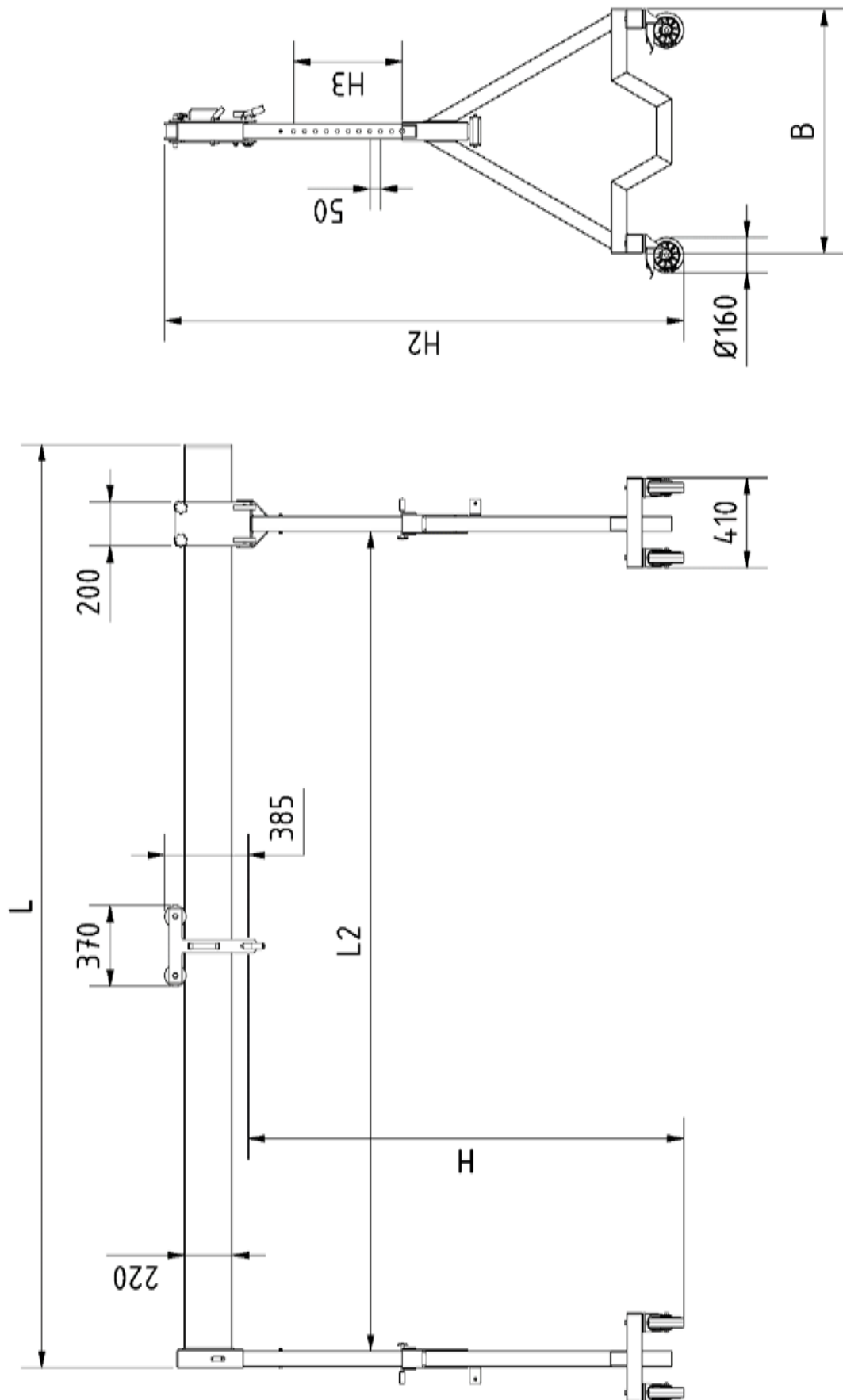

Fig. Crane Moveable under Load model Mini 4m carrier

5 Diagram

	H	H2	H3	B	L	L2
Mini	1500 - 2000	1885 - 2385	500	1120	2217 - 8097	1000 - 7850
Standard	2000 - 3000	2885 - 3385	1000	1695		
Maxi	2250 - 3500	2635 - 3885	1250	1985		

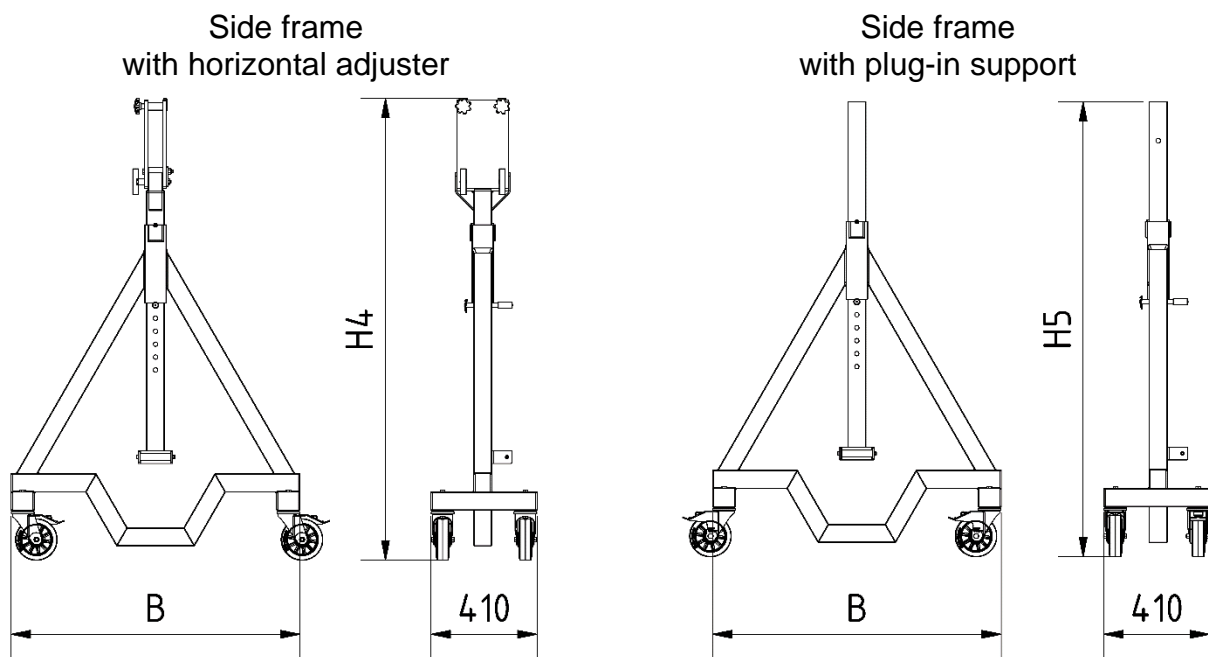

Fig. Side frame crane Moveable under Load model Mini

	H4	H4 no hori.	H5
Mini	1785	1500	1755
Standard	2275	1995	2255
Maxi	2525	2245	2500

6 Exploded diagram

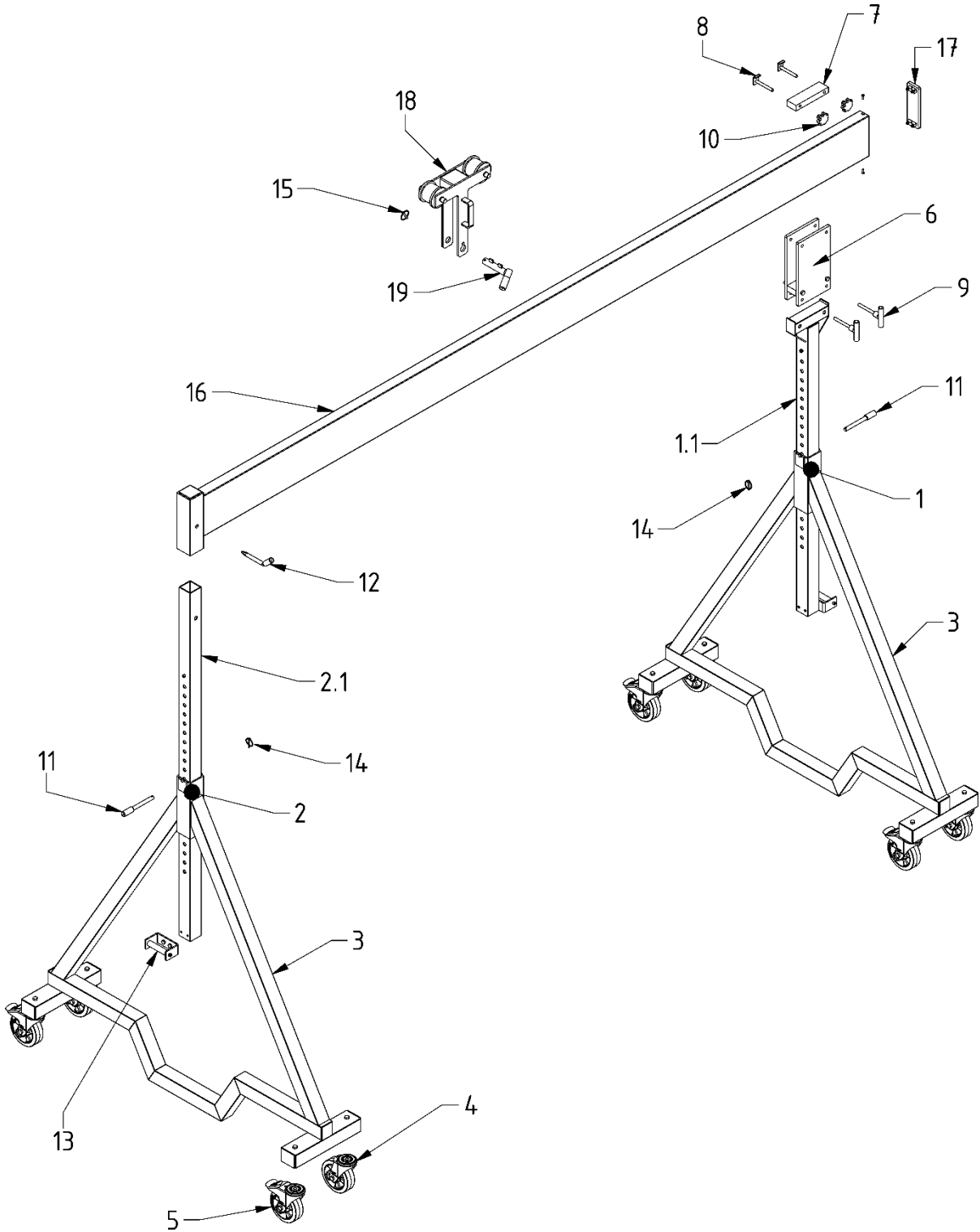

Fig. Crane Moveable under Load model Mini 4m carrier

6 Spare parts list

Pos.	Article no.:	Description	Quantity
1	121100	Side frame *WH Mini (assembly)	1
	122100	Side frame *WH Standard (assembly)	
	123100	Side frame *WH Maxi (assembly)	
1.1	121400	Carrier support *WH Mini	1
	122400	Carrier support *WH Standard	
	123400	Carrier support *WH Maxi	
2	121200	Side frame **WP Mini (assembly)	1
	122200	Side frame **WP Standard (assembly)	
	123200	Side frame **WP Maxi (assembly)	
2.1	121500	Carrier support **WP Mini	1
	122500	Carrier support **WP Standard	
	123500	Carrier support **WP Maxi	
3	121300	Cross beam Mini	2
	122300	Cross beam Standard	
	123300	Cross beam Maxi	
4	041100	Castor wheel no arrestor crane mobile	4
5	041200	Castor wheel with arrestor crane mobile	4
6	192100	Horizontal adjuster (assembly)	1
7	192140	Spacer plate 2	1
8	192150	Clamping screw 1	2
9	192160	Clamping screw 2	2
10	192180	Star handle	2
11	194100	Plug-in bolt	2
12	195100	Carrier safety bolt	4
13	196100	Handle	2
14	197100	Clip pin (small)	6
15	197200	Clip pin (large)	1
16	212000 - 218000	2m - 8m aluminium carrier (assembly)	1
17	219100	Cover plate	1
18	221000	Trolley - assembly	1
19	229000	Trolley plug-in bolt	1

*WH = with horizontal adjuster **WP = with plug-in support

7 Assembling the aluminium quick-assembly gantry crane

- 7.1 Remove the carrier safety bolts of the Side frame with plug-in support as shown in figs. 1 and 2.

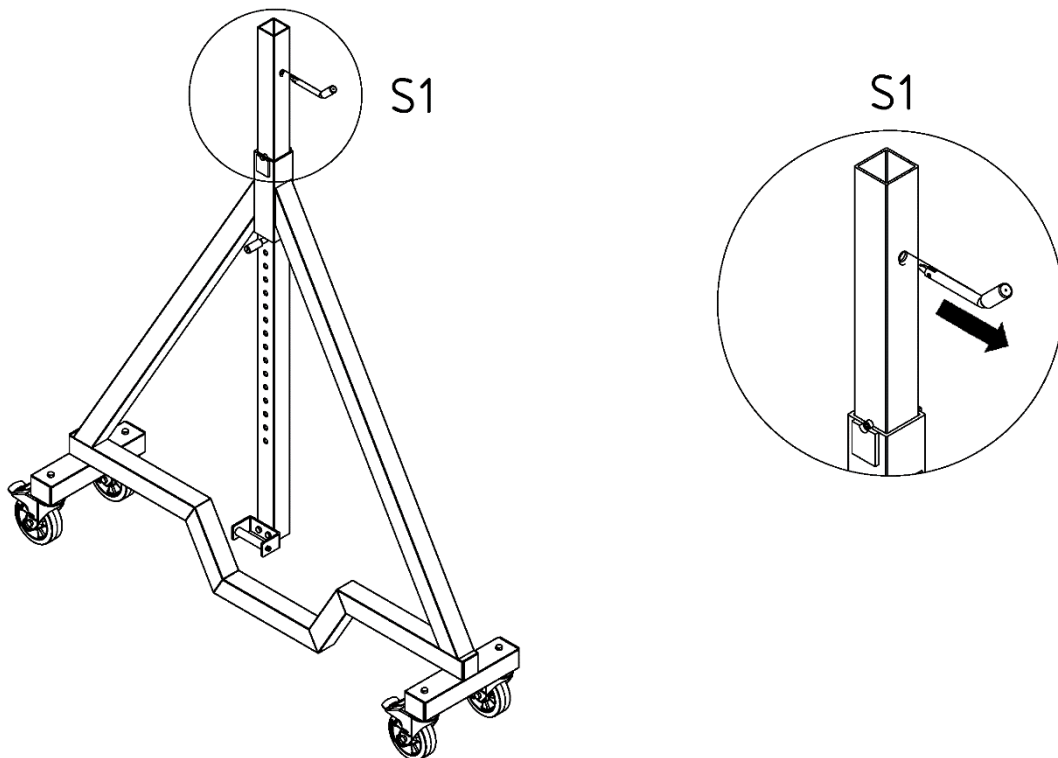

Fig. 1

- 7.2 Loosen clamping screw 2 as shown in fig. 2. Loosen and remove the star knob nuts on the horizontal adjuster. Remove clamping screws 1 and spacer plate 2.

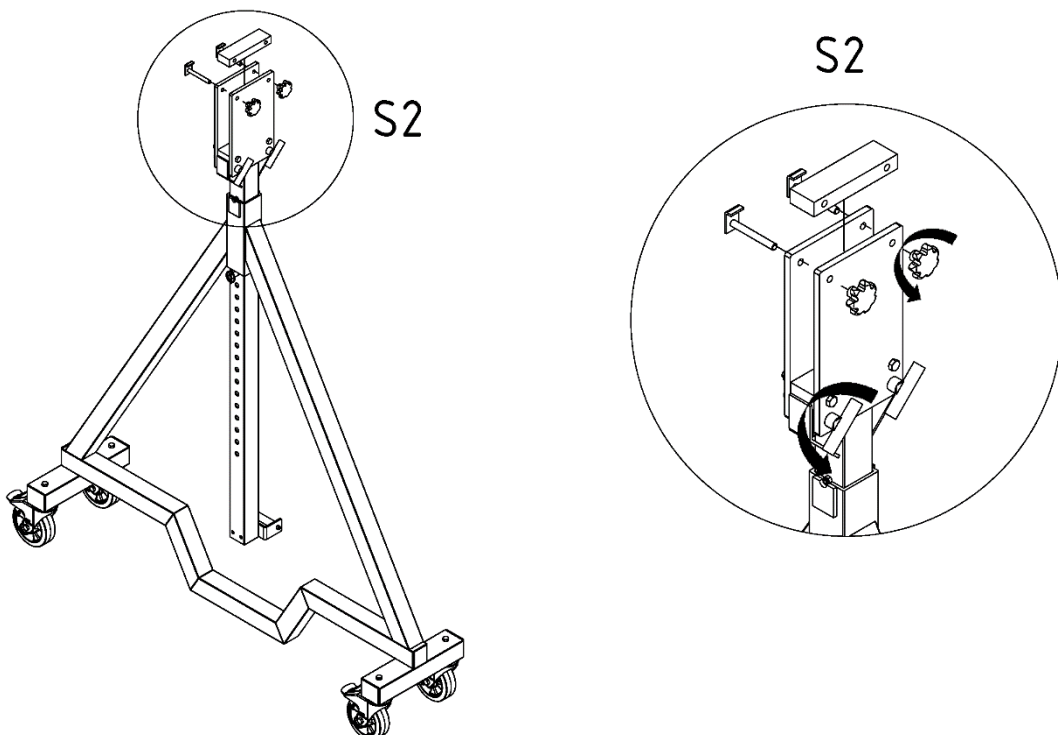

Fig. 2

- 7.3 Now place the aluminium carrier on the Side frames as shown in fig. 3. Make sure that the sleeve reception, which is welded to one end of the aluminium carrier, is placed over the carrier support of the Side frame with plug-in support. The other end of the aluminium carrier is inserted into the horizontal adjuster on the carrier support of the opposite Side frame.
- 7.4 Insert the carrier safety bolt through the hole in the sleeve reception of the aluminium carrier, as shown in fig. 3. Now place spacer plate 2 onto the carrier and re-insert clamping screws 1. Screw on the star knob nuts and retighten clamping screws 2 to clamp the aluminium carrier in this position.

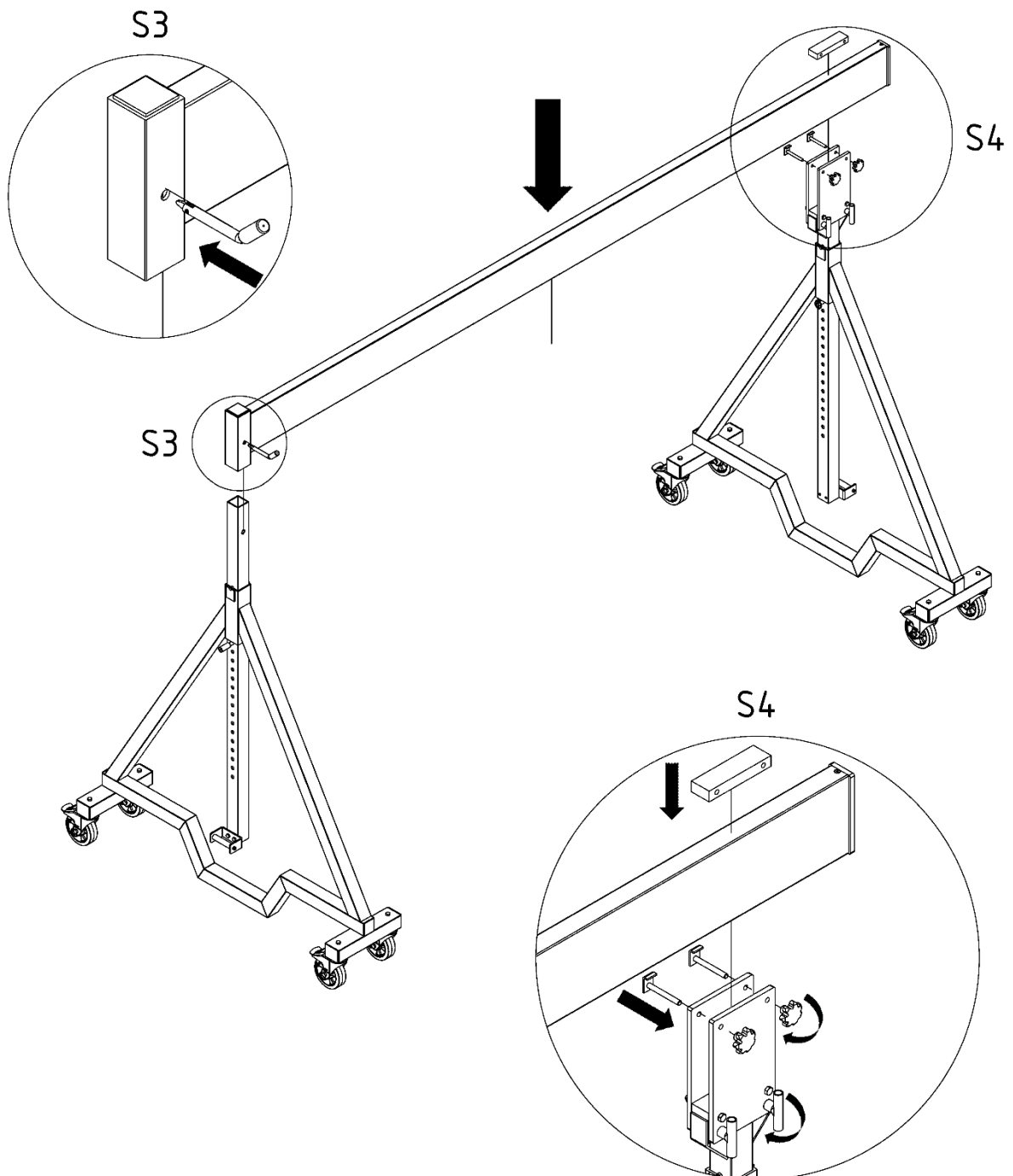

Fig. 3

7.5 Next, place the trolley on to the aluminium carrier as shown in fig. 4 and insert the plug-in bolt for the trolley into the corresponding guide.

Caution: *The trolley safety bolt must always be secured with a clip pin!*

Caution: *Secure the trolley against unwanted rolling!*

7.6 The final step is to set the required working height by extending the carrier supports and setting the appropriate height using the plug-in bolts.

Caution: *The plug-in bolts must always be secured with a clip pin!*

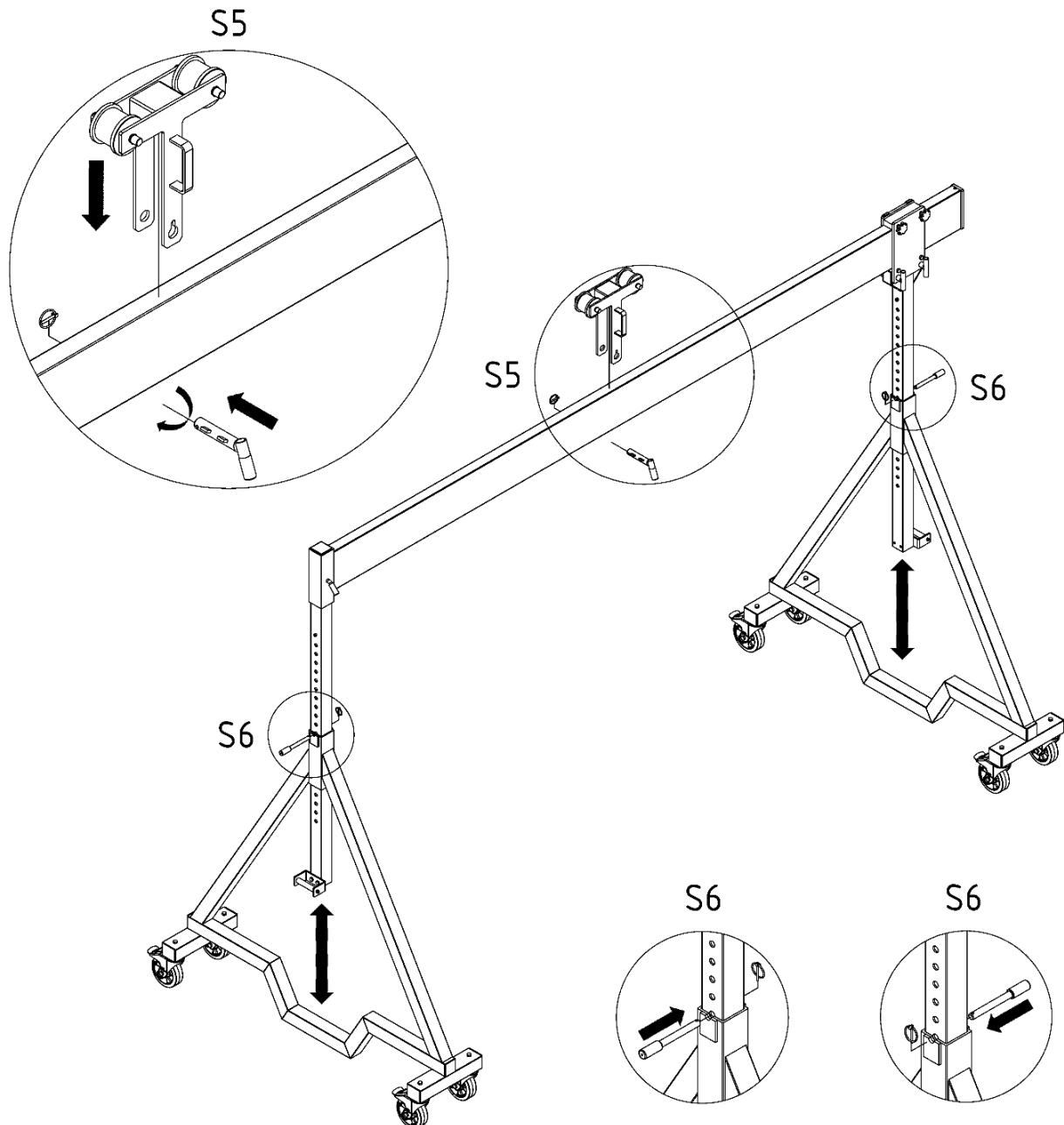

Fig. 4

7.7 Dismantling takes place in the reverse order, while ensuring that the trolley is either completely removed from the aluminium carrier or secured to avoid rolling.

8 Technical data

	Article no.:	Load capacity [kg]	Carrier length		Weight [kg]
Model Mini	121000-2	1000	2 m	2217 mm	117
	121000-3	1000	3 m	3217mm	127
	121000-4	1000	4 m	4217 mm	136
	121000-5	1000	5 m	5217 mm	146
	121000-6	750	6 m	6217 mm	155
	121000-7	500	7 m	7217 mm	165
	121000-8	500	8 m	8097 mm	174
Standard Model	122000-2	1000	2 m	2217 mm	139
	122000-3	1000	3 m	3217mm	149
	122000-4	1000	4 m	4217 mm	158
	122000-5	1000	5 m	5217 mm	168
	122000-6	750	6 m	6217 mm	177
	122000-7	500	7 m	7217 mm	187
	122000-8	500	8 m	8097 mm	196
Maxi Model	123000-2	1000	2 m	2217 mm	149
	123000-3	1000	3 m	3217mm	159
	123000-4	1000	4 m	4217 mm	168
	123000-5	1000	5 m	5217 mm	178
	123000-6	750	6 m	6217 mm	187
	123000-7	500	7 m	7217 mm	197
	123000-8	500	8 m	8097 mm	206

9 Safety hazards

- 9.1 If the trolley is not secured against rolling and the aluminium carrier is slightly in an inclined position, the trolley will start moving.
- 9.2 Inappropriate handling while adjusting the carrier supports may lead to injury.
- 9.3 Adjusting the height of the carrier supports should be done slowly to avoid fingers getting caught.
ATTENTION Risk of crushing fingers.
- 9.4 If the distance between the two cross beams is very low, the structural safety of the ASP must be reviewed.
- 9.5 The ASP may fall over if wind speeds exceed 40 km/h.
- 9.6 If there are cracks in the weld seams, load bearing parts may break and cause the load to drop.

10 Maintenance, checks, repairs and cleaning

10.1 Maintenance

Maintenance intervals depend on the operating time.

In extremely dusty and dirty environments, maintenance intervals must be adjusted accordingly.

Time interval	Maintenance work
1 day after first operation	Check that all safety bolts are locked and pins are installed.
Daily before starting operation	Visual and operational check of all load-bearing parts for damage. Check all weld seams on load-bearing parts.
Weekly	Visual check and cleaning
Yearly	Inspection to be performed by an expert

Improperly performed work

Improperly performed work can lead to immediate or later injuries or damage.

- Only allow any pending maintenance work to be performed by sufficiently qualified personnel.
- Keep the enclosed original documentation to hand.
- Observe the safety regulations.

10.2 Checks

The operating company must ensure that the ASP is inspected whenever necessary, but at least once every year, by an expert.

Recognized faults must be eliminated immediately.

The Employer's Liability Insurance Association regulation for cranes DGUV Regulation 52 must be observed.

10.3 Repairs

Repairs may only be performed by persons having the necessary skills and knowledge.

Before putting the ASP back into operation, it must be subjected to an extraordinary inspection by an expert.

10.4 Cleaning

Clean the ASP from adhering soiling and material encrustations.

Dispose of the cleaned soiling according to the currently valid regulations.

Information: Wrong cleaning agents

When cleaning, do not use:

- *aggressive cleaning agents*
- *easily inflammable solutions*
- *substances that are harmful to health*
- *agents containing trichloroethylene, perchloroethylene, or tetrachloroethylene*

11 Safety rules and regulations

11.1 Regulations

The Employer's Liability Insurance Association regulation DGUV 52 / 53 (previously BGV D6 / GUV-V D6) applies.

11.2 Personnel requirements

The ASP may only be operated by authorised persons.

Each operator must have at least read and understood this documentation.

11.3 Operational and visual check prior to each use

The ASP must be subjected to a visual inspection and functional check prior to each use. Especially load-bearing parts and weld seams must be checked for damage. Do not operate in case of fault. Any fault must be eliminated by a qualified expert.

11.4 Stability

Before assembling, please check that the ground (on which the crane is to stand) is able to withstand the loads to be carried.

11.5 Unauthorised Modifications

Unauthorised modifications of the ASP or self-constructed additional equipment are prohibited.

12 List of hazards as per DIN EN ISO 12100

Pos.	Hazards	Body parts	Solution / Warning
1	Mechanical hazards		
1	- Location - Mass and stability - Mass and acceleration - Insufficient mechanical stability	Persons Operator and third persons Operator and third persons Operator and third persons	Warning label on the crane Briefing/instruction Briefing/instruction Comply with user and maintenance manuals
1.1	Contusion	By load/ operator and third persons	Adhere to safety clearances Observe load oscillation and stopping distances
	Contusion	Operator	Keep safety clearances
	Contusion	Limit stop/Operator	Keep safety clearances
	Contusion	By load on environment / operator/foot	Keep safety clearances

Pos.	Hazards	Body parts	Solution / Warning
1.2	Shearing	Trolley / path / wall / support / operator, hand	Adhere to safety clearances/ observe load oscillation/ensure means of escape and retreat
1.6	Shock	Load oscillation/operator	Keep safety clearances
1.10	Ejection of parts	Load/Operator	Keep safety clearances
1.11	Stability	Ground, floor/ operator	Leave danger zone If possible, lower load immediately, stop the crane Place crane and load only on sufficiently load-bearing ground
1.12	Slipping, stumbling, falling	Insufficient stability/ operator	Keep gangways free, ensure sufficient stability
2	Electrical hazards		
2.1	Electrical contact	Damaged insulation of elec. conductors, supply cables/operator	Halt operation, cut off power supply, replace elec. conductors Move supply cables securely. Operator contact prohibited
2.4	External effect	E.g. on supply cables by other means of transportation/ operator and third persons	Observe crane, load and environment closely
3	Temperature-related hazards		
3.1	Burns	Elec. operated crane/operator	Observe regulations in particular in potentially explosive area
7	Hazards caused by materials and substances		
7	Materials (oils, greases, lubricants)	Swivel drive, hoist Operator/third persons/environment	Refer to special user manual for hoists and drives
7.2	Fire and explosion	Elec. operated crane/ operator and third persons	Not suitable for potentially explosive areas
8	Hazards caused by neglecting ergonomic principles		
8.4	Inappropriate localised lighting	Operator/third persons	Ensure sufficient visibility and light
8.6	Human error	Operator	Training

Pos.	Hazards	Body parts	Solution / Warning
10	Hazards caused by unexpected starting, unexpected racing/overrun		
10+ 10.3	Disruption of energy supply Malfunction of control system	Operator/third persons	Activate emergency stop and initiate troubleshooting measures by a qualified expert
10.4	Incorrect assembly	Operator	Halt operation, troubleshoot
10.5	Racing, unexpected loss of machine stability	Operator	Lower load, secure crane
11	No means to take the machine out of operation under optimal conditions		
11	Failure/wrong arrangement of protective measures	Operator / third persons	Take all necessary measures to reduce the risk potential
11.1+ 11.2	Protection devices	Operator / third persons	Check protection devices
11.3	Starting and braking systems	Wheel + steering stop/Operator	Before starting, press wheel + steering stop
	Starting and braking systems	Control panel/Operator	In case of faulty control button activate emergency stop. Replace parts
11.4+ 11.5	Safety symbols/signals Information device and alarm.	Main switch, emergency stop/operator	Before starting operation, check functionality
11.6	Energy supply cut-off device	Main switch, emergency stop/operator	Before starting operation check functionality
11.7	Emergency measures	Working area/Operator	Activate emergency stop if this reduces the danger
11.9	Equipment for safe adjustment and/or maintenance	Operator	Before performing any work on the crane lock the main switch to the "OFF" position.

13 Hazard areas:

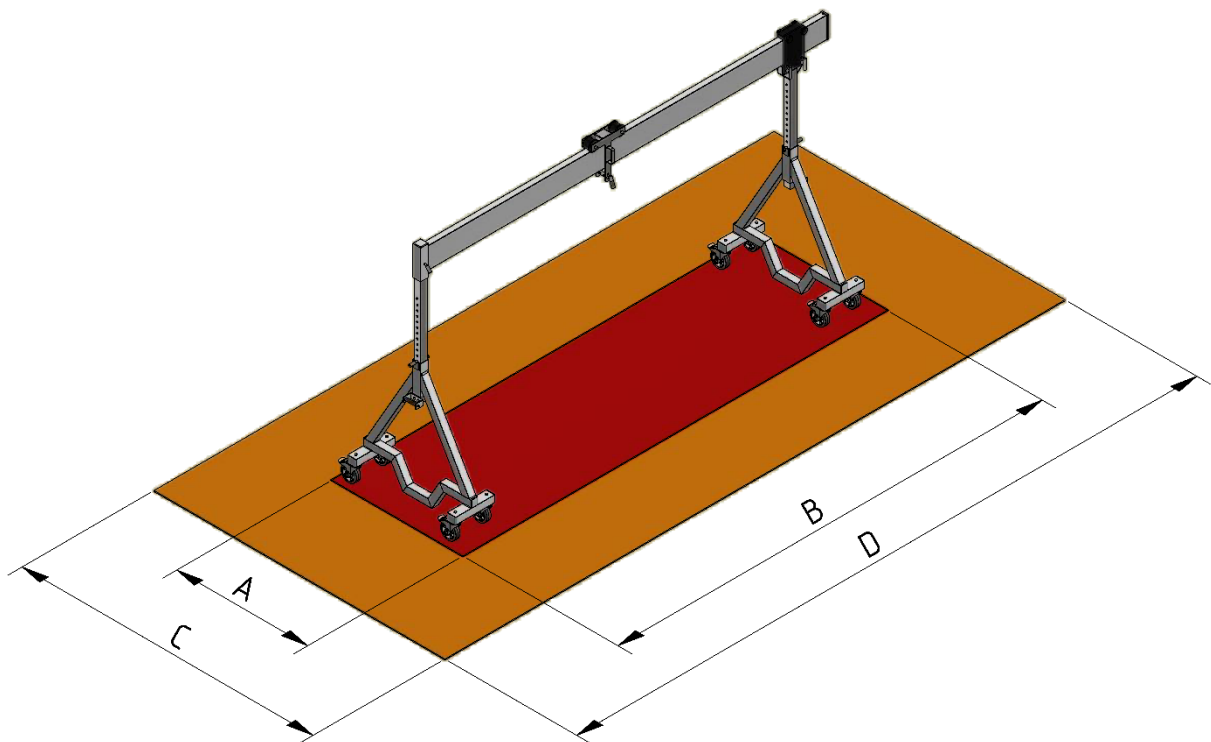

Fig. Crane Moveable under Load model Mini 4m carrier



Red area – Risk of death!

In this area there is risk of death! No access to this area as this is where loads are lifted and moved.



Orange area – Danger!

In this area there is risk of injury should the crane tip over. For *dimensions* please refer to the following table.

	A	B	C	D
Mini	1400	2217 - 8097 (carrier length)	4770	4217 - 10217 (carrier length + 1 m on each side)
Standard	2000		6770	
Maxi	2300		7770	

14 Safety instructions

14.1 Warnings and Symbols

The following designations and symbols are employed in the user manual for particularly important information:

- Note** Special information on economic use of the equipment/machine
- Caution** Special instructions, dos and don'ts to avoid damage
- Danger** Information, dos and don'ts for prevention of extensive property damage and personal injuries

14.2 Non-observance of safety instructions

Failure to observe the safety instructions can lead to severe or even deadly injuries.

Always observe the following safety instructions:

- Observe and follow this user manual.
- Always wear the required personnel protection equipment, see Personnel protection equipment - PPE.
- Operate the crane only, when the aluminium carrier is exactly aligned in horizontal and vertical direction.
- Do not operate the crane on slippery surfaces like for example on frozen surfaces.
- Secure the trolley against unnoticed movement with or without load due to an inclined position.
- Do not operate the crane in potentially explosive environments.
- Do not operate the crane if it is obviously damaged.
- Do not operate the crane if unauthorised persons are staying in the hazard area.
- Do not step or reach out under loads, which are suspended on the crane.
- Use only approved ladders or similar equipment to work on the crane. Never use components of the crane, e.g. side panels, to climb on to the crane.
- Always observe the generally applicable safety standards.

14.3 Personnel protection equipment – PPE

The personnel protection equipment depends on the loads to be moved.

It must be provided by the operating company and must be worn by the operator.

The personnel protection equipment may include:

- **Safety helmet**
- **Safety gloves**
- **Safety shoes**

All parts of the personnel protection equipment must comply with all legal directives.

The personnel protection equipment must be appropriate for the loads to be moved, according to the operating company's guidelines.

14.4 Fundamentals, intended use

14.4.1 The machine/equipment has been built using cutting-edge technology and according to approved safety regulations. However, operating the machine can present risk to life and limb of the operator or third persons or damage to the machine or other material assets.

14.4.2 Use the machine/equipment only in perfect technical condition and according to intended use, with an awareness of safety and risk and taking the user manual into account! In particular any faults arising that may impair safety must be repaired immediately!

14.4.3 The machine/equipment should only be used for lifting and moving loads. Any other use or any use beyond that, e.g. pulling loads, is considered as contrary to the intended use. The manufacturer/supplier is not responsible for any damages resulting from that. The user alone bears all risks. The intended use also includes observing the user manual as well as the conditions of inspection and maintenance.

14.5 Organisational measures

- 14.5.1 Keep the user manual continuously available at the place of installation of the machine/equipment (in the tool compartment or in the compartment provided for this purpose)!
- 14.5.2 In addition to the user manual, all general legal regulations as well as other binding rules concerning prevention of accidents and environmental protection should be instructed and observed!
- 14.5.3 Complete the user manual with regulations incl. supervision and notification obligations, taking into account the special features of the company regarding work organisation, operating processes and deployed personnel.
- 14.5.4 The personnel assigned to work on the machine must have read the user manual and especially the chapter on Safety Instructions before starting work. Reading the manual during work is too late. This applies in particular to personnel working only occasionally on the machine, e.g. set-up or maintenance.
- 14.5.5 Check at least occasionally that personnel work safely and with an awareness of risk in accordance with the user manual!
- 14.5.6 Personnel may not have long hair worn loose, nor may they wear loose clothes or jewellery including rings. There is risk of injury, e.g. by getting caught or being pulled in.
- 14.5.7 Use personnel protection equipment where necessary or where required by regulations.
- 14.5.8 Observe all safety and hazard warnings on the machine/equipment!
- 14.5.9 Make sure all safety and hazard warnings on the machine/equipment are present and legible!
- 14.5.10 In case of changes regarding safety of the machine/equipment or its performance, stop the machine/equipment immediately and inform the responsible department/person of the fault!
- 14.5.11 Do not perform any changes or modifications of the machine/equipment that could affect the safety without the prior approval of the supplier. This also applies to the installation and adjustment of safety devices and valves and to any welding work on load-bearing parts.
- 14.5.12 Spare parts must correspond to the technical requirements defined by the manufacturer. This is always guaranteed when using original parts.
- 14.5.13 Prescribed intervals for regular maintenance work or else intervals as specified in the user manual must be adhered to!
- 14.5.14 Workshop equipment appropriate to the task in hand is imperative for carrying out maintenance work.
- 14.5.15 Inform personnel of the location and operation of fire extinguishers!
- 14.5.16 Observe fire alarm and firefighting contingencies!

- 14.6 Personnel selection and qualification; basic duties**
- 14.6.1 Work on/with the machine/equipment must only be performed by reliable personnel. Observe the legal minimum age!
 - 14.6.2 Only deploy trained or instructed personnel; clearly define their responsibilities for operation, set-up, maintenance and repair!
 - 14.6.3 Make sure that only authorised personnel work on the machine!
 - 14.6.4 Define the responsibility of the machine operator – also regarding traffic regulations – and permit them refusal of instructions given by third persons that are contrary to safety!
 - 14.6.5 Any personnel in need of training, induction or instruction or working within the scope of general training may only work on the machine/equipment under permanent supervision by an experienced member of staff!
 - 14.6.6 Work on the electrical equipment of the machine/equipment must only be performed by an electrically skilled person or other instructed persons under the direction and supervision of an electrically skilled person in accordance with electrotechnical regulations.
 - 14.6.7 Work on running gears, braking and steering systems must only be performed by specially trained personnel!
- 14.7 Safety regulations regarding different phases of operation**
- 14.7.1 Normal operation
 - 14.7.1.1 Avoid any procedures that raise safety concerns!
 - 14.7.1.2 Get acquainted with the work environment on site before starting work. The work environment includes e.g. obstacles in the work and traffic areas, load capacity of the ground and required safeguarding of the building site from the public traffic zone.
 - 14.7.1.3 Take measures to operate the machine/equipment only in a safe and functioning state! Operate the machine only if all protection and safety equipment such as detachable protective equipment, emergency stops, sound insulation equipment, suction devices are available and functioning!
 - 14.7.1.4 Check the machine/equipment at least once per shift to detect any external damage or fault. Inform the responsible department/person immediately of any changes (incl. changes in the operating behaviour)! If necessary, shut the machine down immediately and secure it.
 - 14.7.1.5 In case of malfunctions, stop and lock the machine/equipment immediately! Have the malfunctions repaired without delay!
 - 14.7.1.6 Observe indicator lamps and procedures for switching on and off in accordance with the user manual!
 - 14.7.1.7 Before switching on/starting the machine/equipment, ensure nobody is put at risk of harm by starting the machine/equipment!
 - 14.7.1.8 Check before starting the operation/work that brakes, steering, signalling and lighting systems are fully operational!
 - 14.7.1.9 Before moving the machine make sure that the accessories are safely stored to avoid accidents!
 - 14.7.1.10 Always switch on the lights in case of reduced visibility or darkness!
 - 14.7.1.11 Always ensure sufficient clearance when negotiating subways, bridges, tunnels, overhead lines, etc!
 - 14.7.1.12 Always ensure sufficient clearance to edges of foundation ditches and slopes!

- 14.7.1.13 Avoid any working method that affects the stability of the machine!
- 14.7.1.14 Do not drive crosswise on slopes; always carry the equipment and the loaded material near the ground, especially when driving down a slope!
- 14.7.1.15 When leaving the machine, always lock it in order to prevent it from moving unintentionally and protect it against unauthorised use.
- 14.7.2 Special work while operating the machine/equipment and maintenance work as well as troubleshooting during work flow; disposal
- 14.7.2.1 Observe the working procedures and dates specified in the user manual for set-up, maintenance and inspection incl. information on replacing parts/equipment parts! These operations must be performed by qualified personnel only.
- 14.7.2.2 Inform the operating staff before proceeding with special and maintenance work! Appoint a supervisor!
- 14.7.2.3 For all work regarding operation, adjustment of production, changing and setting of the machine/equipment and the safety equipment as well as inspection, maintenance and repair, please observe the start-up/stop sequences according to the user manual and the guidelines concerning repair work!
- 14.7.2.4 Cordon off any necessary maintenance areas including the space around them!
- 14.7.2.5 If the machine is completely switched off for maintenance and repair work, it has to be protected against unexpected restart:
 - lock the main control units and remove the key and/or
 - put a warning sign on the main switch.
- 14.7.2.6 Only proceed with maintenance or repair work when a machine is on even and solid ground and secured against moving and buckling!
- 14.7.2.7 When replacing individual parts and larger subassemblies, these must be fixed and secured to hoisting devices to avoid any dangers that may arise. Only use suitable hoisting devices in perfect technical condition and load suspension devices of sufficient carrying load! Do not stand or work under suspended loads.
- 14.7.2.8 Only experienced personnel should be charged with attaching loads and instructing crane operators! The instructor should either be in sight of or have voice contact with the operator.
- 14.7.2.9 For performing assembly work above body height, use the climbing aids or platforms provided for this purpose or similar safety-compliant equipment. Do not use parts of the machine as climbing aids! Wear a safety harness when carrying out maintenance work at greater heights! Make sure that handles, steps, rails, platforms and ladders are free from dirt, snow and ice!
- 14.7.2.10 Before proceeding with maintenance/repair work, remove any oil, fuel or cleaning agents from the machine, especially from the connections and screw fittings! Do not use any aggressive cleaning products! Use lint-free cloths!
- 14.7.2.11 Before cleaning the machine with water, steam jet (high-pressure cleaning device) or other cleaning agents, cover/tape up all openings where for operational or safety reasons no water/steam/cleaning agents should get in. Electric motors and switch cabinets are particularly at risk.
- 14.7.2.12 Completely remove covers/tapes after cleaning!

- 14.7.2.13 Always tighten slackened screw fittings during maintenance and repair work!
- 14.7.2.14 If it is necessary to remove safety equipment for set-up, maintenance and repair, this must be reinstalled and checked immediately following the maintenance and repair work.
- 14.7.2.15 Ensure the safe and environmentally friendly disposal of operating materials and auxiliary supplies as well as replacement parts!

14.8 Information regarding special hazard types

- 14.8.1 Electric power
 - 14.8.1.1 Only use original fuses of the prescribed amperage! Stop the machine/equipment immediately in case of disruption of the power supply!
 - 14.8.1.2 Make sure that there is sufficient clearance between the machine/equipment and the electric overhead lines! When working near overhead lines make sure that the equipment is not near the lines. Risk of death! Acquaint yourself with the required safety clearances!
 - 14.8.1.3 After each contact with power lines - Do not leave the machine - Move the machine out of the danger zone - Caution external persons against getting closer and touching the machine - Arrange for power supply to be cut off - Only leave the machine if the touched/damaged line is definitely disconnected from the power supply!
 - 14.8.1.4 Work on the electrical equipment of the machine/equipment must only be performed by an electrically skilled person or other instructed persons under the direction and supervision of an electrically skilled person in accordance with the electrotechnical regulations.
 - 14.8.1.5 If specified, the power supply of machine/equipment parts on which inspection, maintenance and repair work is performed must be cut off. The disconnected parts must first be inspected to determine they are volt-free, before being earthed and short-circuited and also insulate neighbouring live parts!
 - 14.8.1.6 The electrical equipment of a machine/equipment must be checked/inspected at regular intervals. Immediately repair faults such as slackened connections or scorched cables.
 - 14.8.1.7 If work on live parts is necessary, call in a second person to operate the emergency stop or main switch in case of emergency. Close off the work area with a red/white safety chain and a warning sign. Use only insulated tools!
- 14.8.2 Gas, dust, steam, smoke
 - 14.8.2.1 Observe the applicable regulations for the respective place of use!
 - 14.8.2.2 Only perform welding, burning and grinding work if explicitly authorised; this entails severe risk of fire and explosion!
 - 14.8.2.3 Remove any dust and combustible material from the machine/equipment and its environment and ensure sufficient ventilation (risk of explosion) before proceeding with welding, burning and grinding work!
- 14.8.3 Hydraulics and pneumatics
 - 14.8.3.1 Check all lines, hoses and screw fittings at regular intervals in order to detect leaks and any damage visible from the outside! Have the malfunctions repaired without delay! Splashing oil may lead to injuries and fire.

- 14.8.3.2 Depressurise all system sections to be opened and pressurised pipes (hydraulics, compressed air) before beginning repair work according to the components descriptions!
- 14.8.3.3 Lay and mount hydraulic and pneumatic pipes correctly! Do not mix up the connections! The fittings, lengths and quality of the hoses must comply with requirements.
- 14.8.4 Noise
 - 14.8.4.1 The sound insulation devices on the machine/equipment must always be in protective position during operation.
 - 14.8.4.2 Compulsory ear protection equipment must be worn!
- 14.8.5 Oils, greases and other chemical substances
 - 14.8.5.1 When handling oils, greases and other chemical substances, observe the product-related safety regulations!
 - 14.8.5.2 Be careful when handling hot operating materials and auxiliary supplies (risk of burning and scalding)!
- 14.9 Transportation; restarting**
 - 14.9.1 Use only suitable means of transport and hoisting devices of sufficient lifting capacity!
 - 14.9.2 When restarting, proceed in accordance with the user manual!

EC declaration of conformity

in accordance with EU Machinery Directive 2006/42/EC, Appendix II A

We herewith declare that the

Equipment: Aluminium Quick-Assembly Gantry Crane (ASP)
Version: Moveable under Load
Model: Mini – Standard – Maxi
Article no.: 121000 – 122000 – 123000
Load capacity:
Carrier length 2 m – 5 m 1000 kg
Carrier length 6 m 750 kg
Carrier length 7 m – 8 m 500 kg
Carrier length: 2m – 8m (2217 mm – 8097 mm)

complies with the safety regulations.

The CE marking is fixed visibly at the product.

Manufacturer or Supplier: Feltes GmbH, Gerätebau - Gerätevertrieb
Marie-Curie-Straße 9
D-40822 Mettmann

Relevant EC directives: Machinery Directive 2006/42/EC

Applied harmonised standards: DIN EN ISO 12100 - Safety of Machinery
DIN EN 13001-3-1:2013-12 (Steel)
DIN EN 1999-1-1:2014-03 (Aluminium)

Applied national standards and technical specifications, where appropriate and in particular: DIN EN 15011:2014-09
DGUV Regulation 52 (hitherto BGV D6)
DGUV Regulation 53 (hitherto GUV-V D6)

Place, date: Mettmann, 01 February 2017

Identification of the signatory: Norbert Feltes (Managing Director)

Signed: _____



16 Additional documents

Recurring inspection

Product: Aluminium Quick-Assembly Gantry Crane
Version: Moveable under Load
Model: Mini – Standard – Maxi
Manufacturer: Feltes GmbH, Gerätebau - Gerätevertrieb
Year of manufacture: 2017
Article number: 121000 – 122000 – 123000
Load capacity: 500 kg – 1000 kg
Serial number: *You will find the serial number on the identification label which is affixed to the carrier.*
Weight: *Chapter 8 (see page 13)*

1) Inspection before delivery

Visual and functional inspection of the aluminium gantry crane and its components is completed. The product was developed, constructed and produced according to the rules of engineering.

Date: Dispatch day (see delivery note)

Signature: _____

Identification of the signatory: Norbert Feltes (Managing Director)

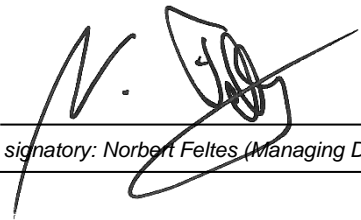

Maintenance log

Date	Signature	Work completed / Remarks

