

PHT-140

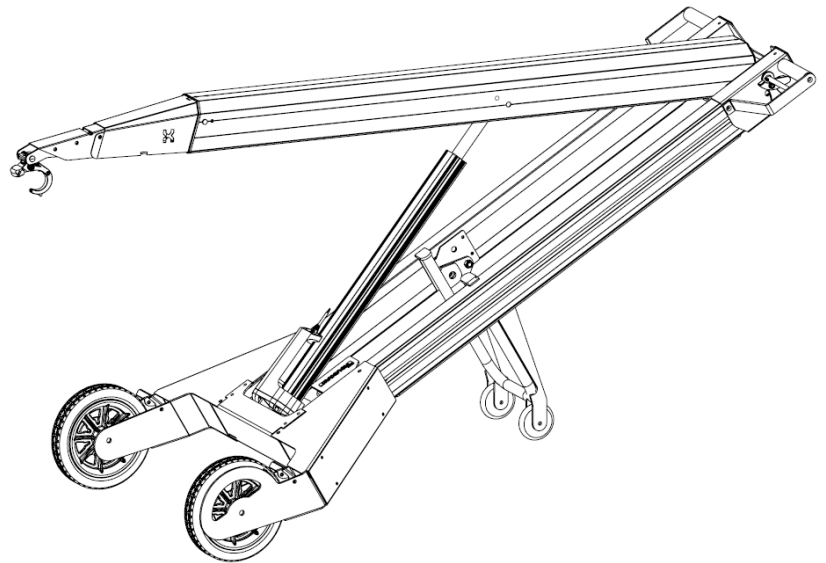

OPERATOR'S MANUAL

CONTENTS

FORWARD.....	3
DISCLAIMER.....	3
1. INTRODUCTION.....	4
2. SAFETY INFORMATION.....	6
2.1 Training.....	6
2.2 Preparation.....	6
2.3 Operation.....	6
2.4 Maintenance and Charging.....	7
2.5 Transport and Storage.....	8
3. OPERATION.....	9
3.1 Controls/Layout.....	9
3.2 General.....	10
3.2.1 Control Hook Reach.....	10
3.2.2 Control Hook Lateral Movements.....	10
3.2.3 Lift and Lower <i>Powered Lifting Arm</i>	10
3.2.4 Steering while unloaded.....	11
3.2.5 Loading and unloading at ground level.....	12
3.2.6a Hook Operation.....	13
3.2.6b Hook Operation.....	14
3.2.7 Operating Brakes.....	15
3.2.8 Ground Conditions.....	16
3.2.9 Transporting load across ground.....	16
3.3 Lift Technique.....	17
3.3.1 Raising & lowering load.....	17
3.3.2 Loading & Unloading at height.....	18
3.3.3 Increased Risk Position.....	20
3.3.4 Topple Scenario.....	20
3.4 Charging.....	21
3.5 Power failure unload procedure.....	21
3.6 Transport and Storage.....	22
4. LOAD AND REACH DATA.....	24
5. SLOPE GUIDE.....	25
7. SAFETY AND INSTRUCTION DECAL.....	28
8. TECHNICAL DATA AND SPECIFICATIONS.....	28
9. LIMITED WARRANTY.....	3139
WARRANTY: (Ex-factory/ Reseller premise).....	31
Warranty exclusions:.....	32
Normal Wear.....	32
Installation, Use and Maintenance.....	32
Other Exclusions.....	32
Responsibility of the consumer under this Limited Warranty:.....	32
Claim Procedure:.....	32
WARRANTY CONTACT INFORMATION:.....	34
10. SALES AND SPARE PARTS.....	35

FORWARD

This manual provides information and procedures to safely operate and maintain the *PHT-140* device. For yours and/or other's safety and protection from injury, carefully read, understand and observe the safety instructions described in this manual.

Keep this manual or a copy of it with the machine. If you lose this manual or need an additional copy, please contact Makinex. This machine is designed and built with user safety in mind; however, it can present hazards if improperly operated and/or serviced. Please follow the operating instructions carefully. If there are any questions regarding operating or servicing of this machine, please contact Makinex.

The information contained in this manual was based on machines in production at the time of publication. Makinex reserves the right to change any portion of this information without notice.

All rights, especially copying and distribution rights are reserved.

Copyright 2014 by Makinex

No part of this publication may be reproduced in any form or by any means, electronic or mechanical, including photocopying, without express written permission from Makinex.

Any type of reproduction or distribution not authorized by Makinex represents an infringement of valid copyrights and will be prosecuted. We expressly reserve the right to make technical modifications, without due notice, which aim at improving our machines or their safety standards.

DISCLAIMER

Makinex and its affiliates take no responsibility for any damage, injury or death resulting from the incorrect or unsafe use of this product. Use of this product should be undertaken by competent persons only. It is the operator's responsibility to ensure that the following safety procedures are followed. If you are unsure, do not operate this product.

EC Declaration of Conformity

In accordance with EN ISO 17050-1:2004

We **Makinex Pty**
of **15 Waltham Street, Artarmon, New South Wales NSW 2064,
Australia**

in accordance with the following Directives:

2004/108/EC	The Electromagnetic Compatibility Directive
2006/42/EC	The Machinery Directive
2011/65/EU	The Restriction of Hazardous Substances Directive

herby declare under our sole responsibility that:

Equipment	Powered Hand Truck
Model number	PHT-140
Serial Number	12000 - 12250

is in conformity with the applicable requirements of the following documents:

Ref. No.	Title	Edition/date
BS EN ISO 12100	Safety of machinery. General principles for design. Risk assessment and risk reduction	2010
BS EN 14492-2	Cranes. Power driven winches and hoists. Power driven hoists	2006+A1:2009
BS EN 61000-6-1	Electromagnetic compatibility (EMC). Generic standards. Immunity for residential, commercial and light-industrial environments	2007
BS EN 61000-6-3	Electromagnetic compatibility (EMC). Generic standards. Emission standard for residential, commercial and light-industrial environments	2007+A1:2011

I hereby declare that the equipment named above has been designed to comply with the relevant sections of the above referenced specifications and is in accordance with the requirements of the Directives.

Signed by: 

Name: **Rory Kennard**
Position: **Director**
Done at: **Sydney**
On: **20.01.2016**



Document ref. No.
PHT CE JAN 2016

The technical documentation for the machinery is available from

Morris Site Machinery
Station Road, Four Ashes, Wolverhampton
West Midlands, WV10 7DB

1. INTRODUCTION

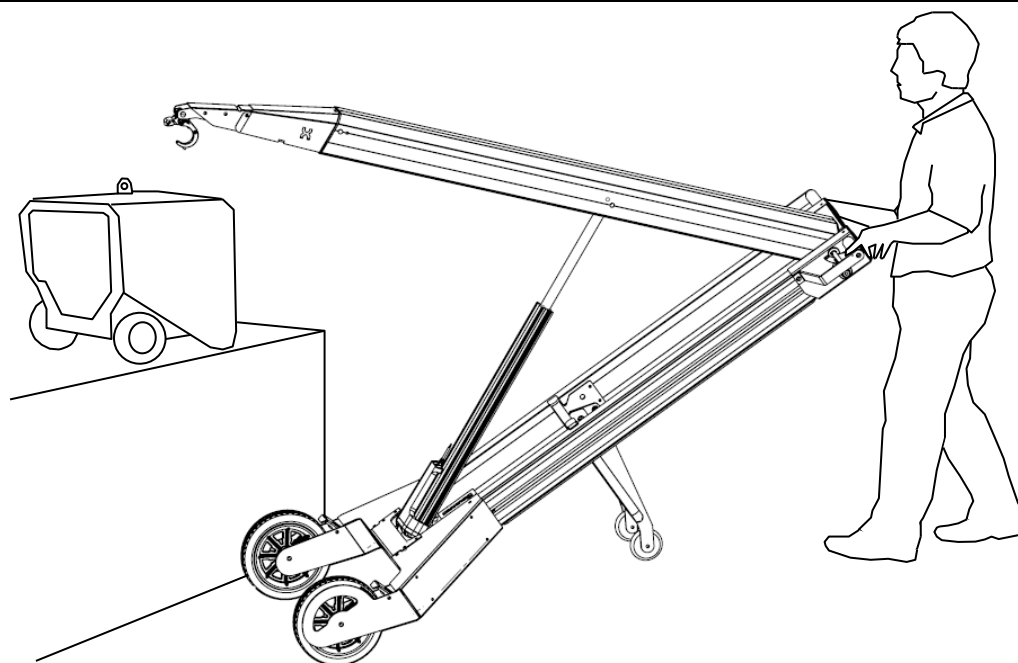

The PHT-140 device is a *hand truck* with a powered lifting arm which can be fitted with various attachment tools. The basic PHT-140 device is configured in combination with a hook attachment fitted to the lifting arm. Typically the device is used for loading small machinery fitted with a lifting eye onto or off vehicles – such as a generator or pressure washer onto a Ute. Operated by a single user, items of up to **140kg** can be ergonomically transferred from ground height to bench height and vice versa as well as transported across the ground as with traditional hand trucks. Because of this capability, the PHT-140 device is a powerful, practical and versatile tool which can be used to reduce the risks of back injury involved in awkward two or three man lifts and without the inherent unwieldiness of large plant like a Forklift.

This operator's manual provides an important guide to using the PHT-140 device safely. As with most wheeled Hand Trucks and Wheelbarrows the PHT-140 device is "user-stabilized" while in use. This is not a "walk behind machine" like a *counterbalanced pallet stacker* or *straddle stacker* which operate on "dead man control" principles. With user-stabilized hand trucks, or even when moving a load with your own hands, load stability depends on load awareness and active load management by the user in response to the feel of the load. For example – in circumstances of managing heavier loads, the user is warned about higher risk by a feeling of increasing force required to control the handles. Increased caution and slower movements should then be exercised.

The instructions contained in this guide will inform the user about considerations such as handling technique, safe ground slope limits, machine tilt and height limits and load weight limits. When used correctly the PHT-140 device is a powerful enhancer of your own body's manual handling versatility.

2. SAFETY INFORMATION

2.1 Training

- All operators should be trained. The owner is responsible for training the users.
- Never let children or untrained people operate or service the equipment.
- Read all attachment manuals.
- The owner/user can prevent and is responsible for accidents or injuries occurring to himself or herself, other people or property.
- Read the Operator's Manual and other training material. If the operator(s) can't read English, it is owner's responsibility to explain this to them.
- Become familiar with the safe operation of the equipment, operator's control, and safety signs.

2.2 Preparation

- Check brakes are operating.
- Inspect machine for deformation damage.
- Check battery power level using the indicator button on the battery.
- Evaluate the terrain to determine what accessories and attachments are needed to properly and safely perform the lift and/or translation of the load. Only use accessories and attachments approved by the manufacturer.
- Check terrain to determine slope + ground condition suitability.
- Try to avoid slopes.
- Wear appropriate Personal Protective Equipment (PPE) clothing; long pants and safety shoes.
- Warn bystanders of planned operation to stay clear.

2.3 Operation

- Keep bystanders away.
- Only operate in good light, keeping away from holes and hidden hazards.
- Do not operate machine in slippery environment.
- Do not operate the machine under the influence of alcohol or drugs.
- Remove obstacles from work area, watch for holes, ruts, or bumps and make sure work area is free of clutter.
- Only operate the machine from behind the handles with each hand on a respective handle, thus avoiding potential pinch or crush injuries.
- Do not exceed the rated lifting capacity – **140kg.**
- Understand the LOAD DATA page and operate within comfortably manageable limits – the PHT-140 device's capacity should never be more than comfortably manageable by user and always less than or equal to **140kg.**
- Do not lift item bulky enough to hit the lift arm in lifted position - some fixed lifting eyes may be positioned so that parts of the load hit the lift arm in raised position.
- Do not lean beyond balanceable point for user as per training procedure.
- Keep each hand on a respective handle while machine is loaded.
- Lower or raise the load while wheels are stationary.
- Do not rest machine on rear wheels with a load
- Do not walk away from the machine even if it seems stable. Machine may tip forward.

- Do not swing the load.
- Do not let person sit on the lift arm.
- Do not raise the load when not in the presence of raised platform or potential bracing wall.
- Always position load at a safe distance from edge of elevated platform.
- Have load at low height when moving across the ground.
- Use the brakes while engaging or disengaging the load at height.
- Move handles slowly with heavy load at height.
- Avoid slopes altogether if possible.
- Never load or unload at height across a slope of any significance – see SLOPE GUIDE in section 5.
- Understand recommended limits on SLOPE GUIDE section 5 and work within these limits.
- Do not exceed slope recommended limits while moving load across ground.
- Do not exceed slope recommended limits while loading or unloading at height.
- Slow down and use extra care on slopes.
- Increase risk of load topple forward when loading up hill.
- Do not tow trailers with the machine.
- Do not lift or lever with any part of machine except the hook.
- Never use the machine as a step or ladder.

2.4 Maintenance and Charging

- Park the machine on level ground.
- Never allow untrained personnel to service the machine.
- Keep all parts in good working condition and all hardware tightened. Replace any worn or damaged decal.
- Keep equipment in good condition.
- Stop and inspect the equipment if you strike an object. Make any necessary repairs before reusing.
- Check for loose fasteners.
- Do not disassemble any part of machine.
- Charge battery regularly.
- DO NOT leave machine switched ON when it is not in use as this will drain the battery and effectively destroy it.
- Charge in a well-ventilated area.
- Do not use damaged leads for charging.
- Do not modify the machine.

2.5 Transport and Storage

- Do not leave machine propped against wall (in flattened state) where it could fall over and cause injury or damage, always lock wheels by applying brakes.
- Store clear of bystanders and make sure it's not obstructing fire exits or walk ways
- Use correct lift posture (bend knees and use leg muscles instead of your back) when loading PHT-140 device on or off transport
- Pack the device for transport so that on/off switch can't be accidentally turned ON during transport
- Store out of weather, do not leave the machine in the rain or wet conditions.

3. OPERATION

3.1 Controls/Layout

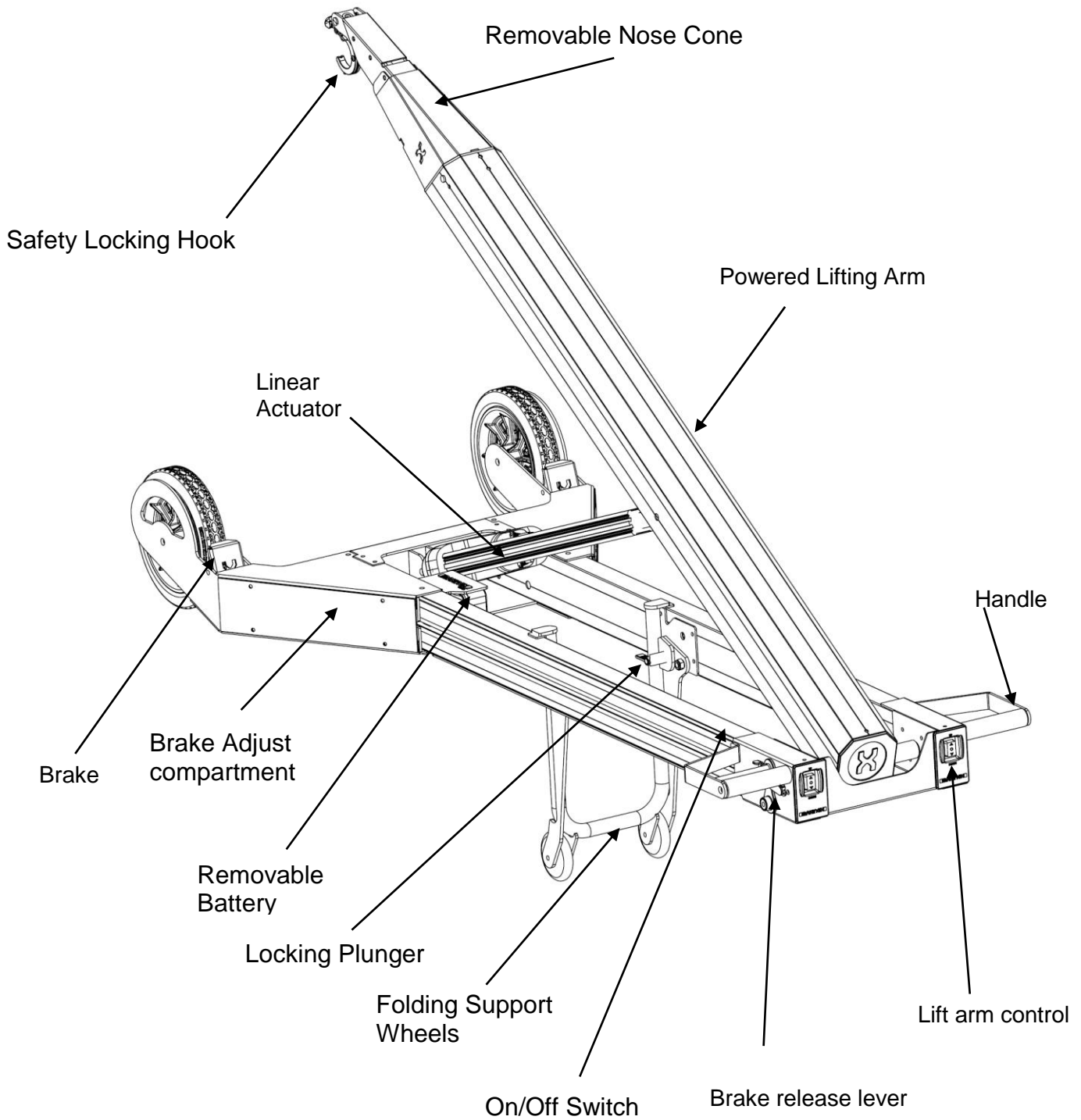

3.2 General

3.2.1 Control Hook Reach

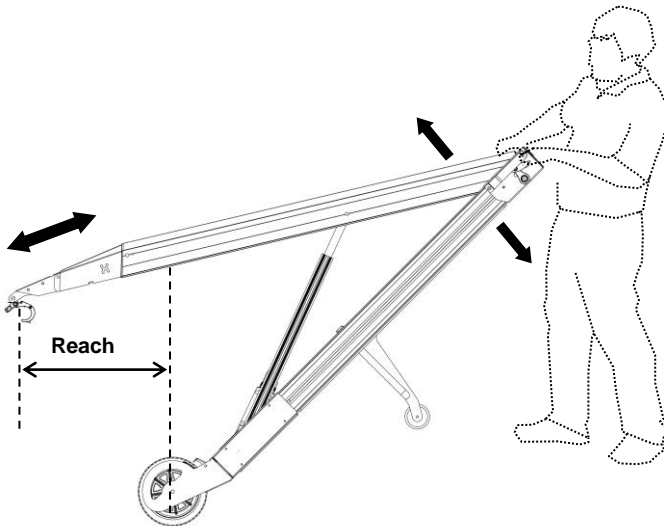

- Hook Reach is the horizontal distance between the wheel axle and the hook.
- Being able to 'reach out' with the hook is fundamental to the operation and function of the PHT-140 device.
- Hook Reach can be varied by raising or lowering the handle.
- With no load on the hook, the weight of the machine must be overcome to lift the handle, but with load on the hook the handles become lighter.

3.2.2 Control Hook Lateral Movements

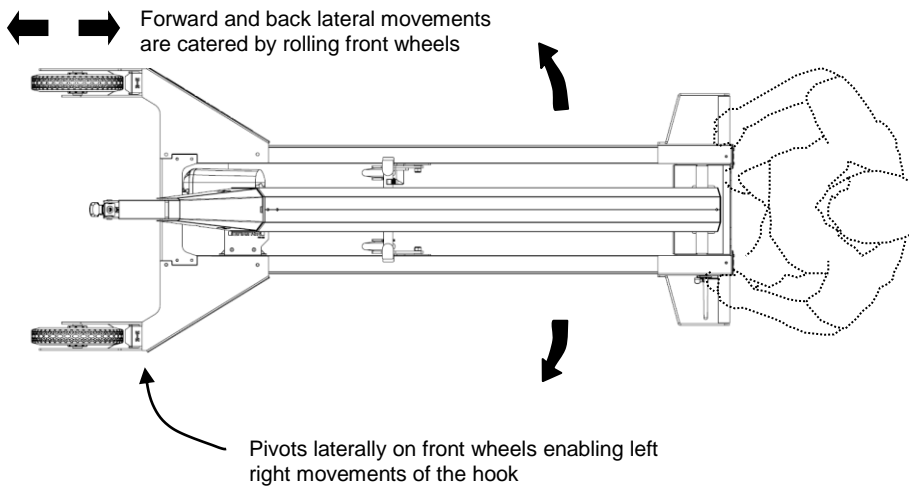

- The hook is moved laterally by making lateral movements with the handles in the opposite direction because laterally the PHT-140 device pivots around the wheels as indicated.

3.2.3 Lift and Lower Powered Lifting Arm

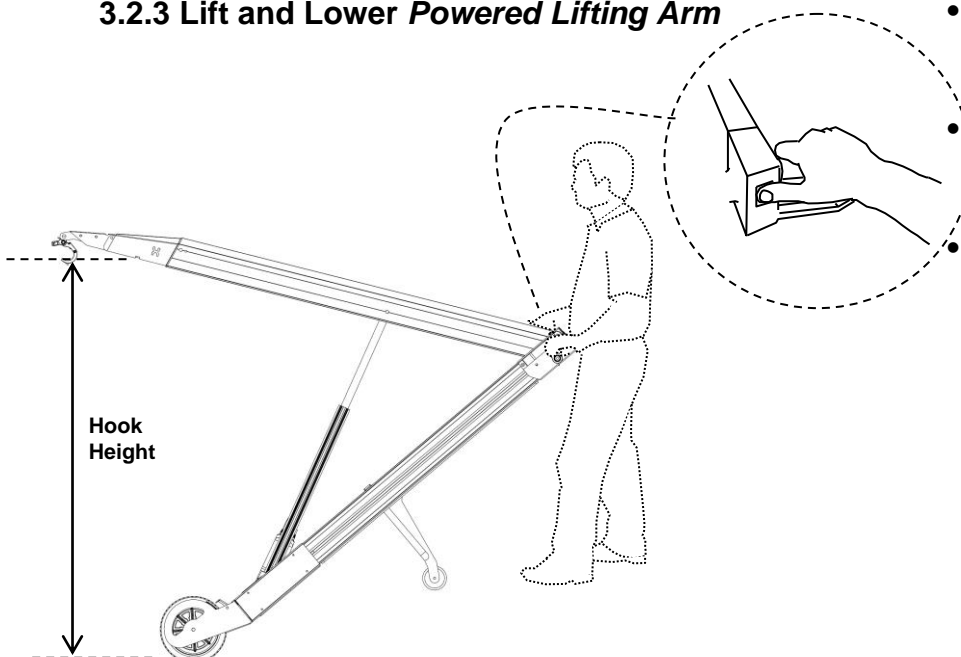

- Lifting the hook and load against gravity is a power-assisted movement.
- To raise or lower the load, operate the up-down rocker switch with the right hand thumb.
- The up-down rocker switch will only operate when the PHT-140 device's switch is set to ON.
- Powered Lifting Arm is currently limited to 140kg Maximum lifting capacity.

3.2.4 Steering while unloaded

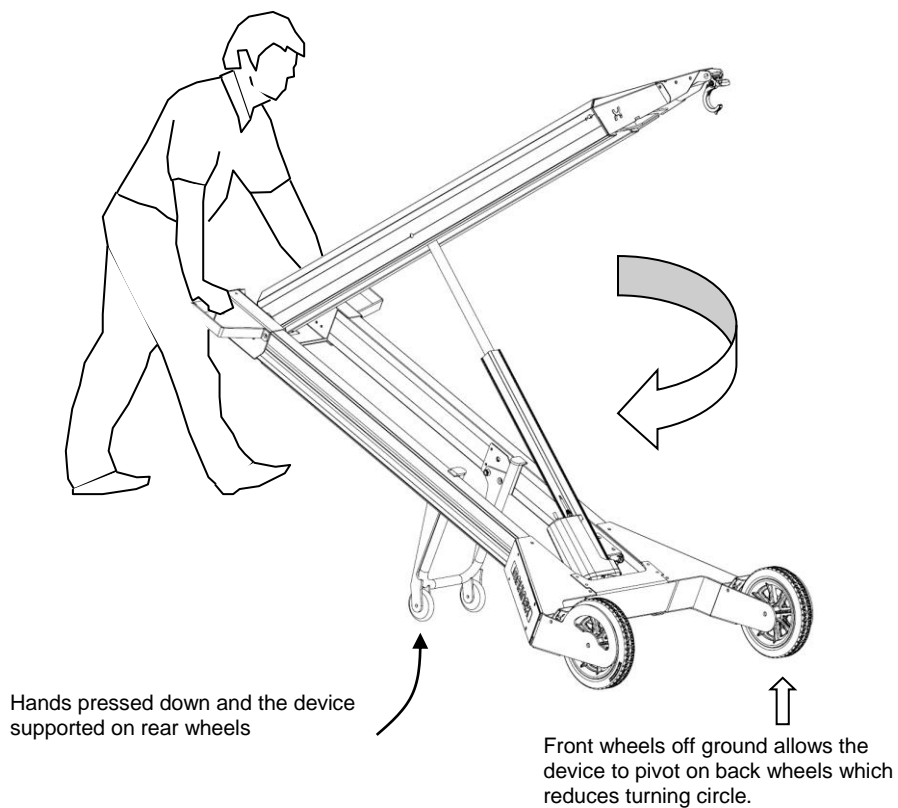

- With rear wheels down, the machine can be easily pushed along in a straight line with no weight on the user's hands. To turn corners, press down on the handle bars to raise the front wheels and allow the machine to be manoeuvred around corners in a tight turning circle.
- This function of laterally pivoting the machine on the rear wheels is particularly useful when lining up the PHT-140 device for a lift.
- The device can be crabbed sideways in order to position the lifting hook in line with lifting eye.

3.2.5 Loading and unloading at ground level

This section explains how to get a load at ground level engaged onto the device and in a hands neutral position. A *hands neutral position* is when the device is loaded and the load is balanced against the weight of the device resulting in minimal balancing force required by the hands.

LOADING PROCEDURE

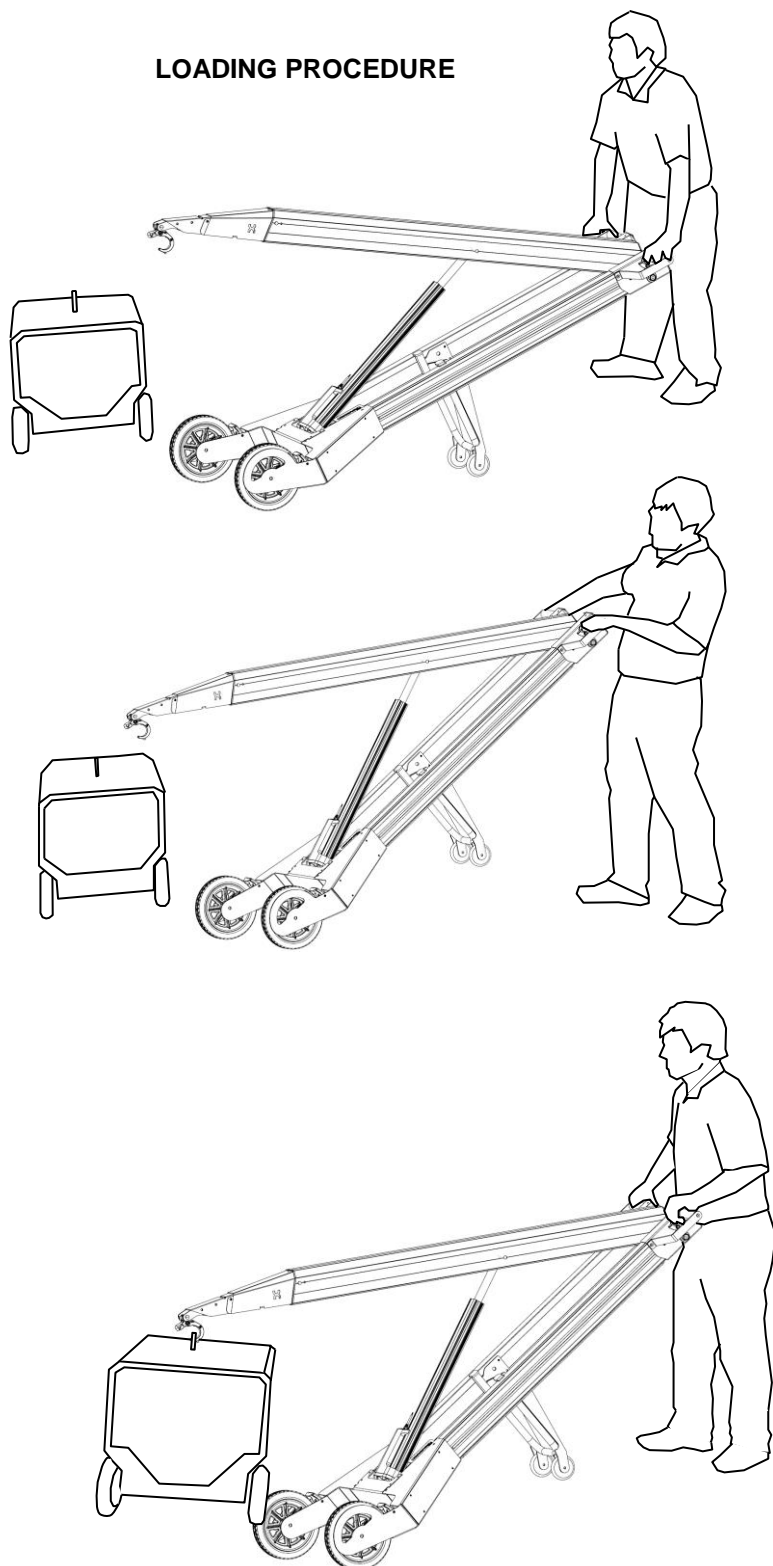

- Prepare hook.
See 'Hook Operation' section 3.2.6 for details of how the hook functions
- Position the device with lift arm slightly higher than the lifting eye
- Bring wheels close to load
- Raise hands to reach hook out sufficiently to engage hook into lifting eye
- Once hook is engaged, raise powered lifting arm and lower hands simultaneously
- Raise lifting arm sufficiently so that the load is clear of wheels
- Adjust hand height to hands neutral position

REVERSE PROCEDURE – UNLOADING AT GROUND LEVEL

- Lift handles and lower lifting arm to put load on the ground
- Disengage hook
- See 'Hook Operation' section 3.2.6 for details of how hook functions

3.2.6a Hook Operation

- Hook operation is designed to enable one man hook engagement and disengagement in a fixed lifting point.
- For flexible lift point such as a sling, second person may be required to engage or disengage the hook from the sling
- Second person should stay clear of the lift operator by 4m while load is not supported by ground or elevated platform

Front on Hook Engagement

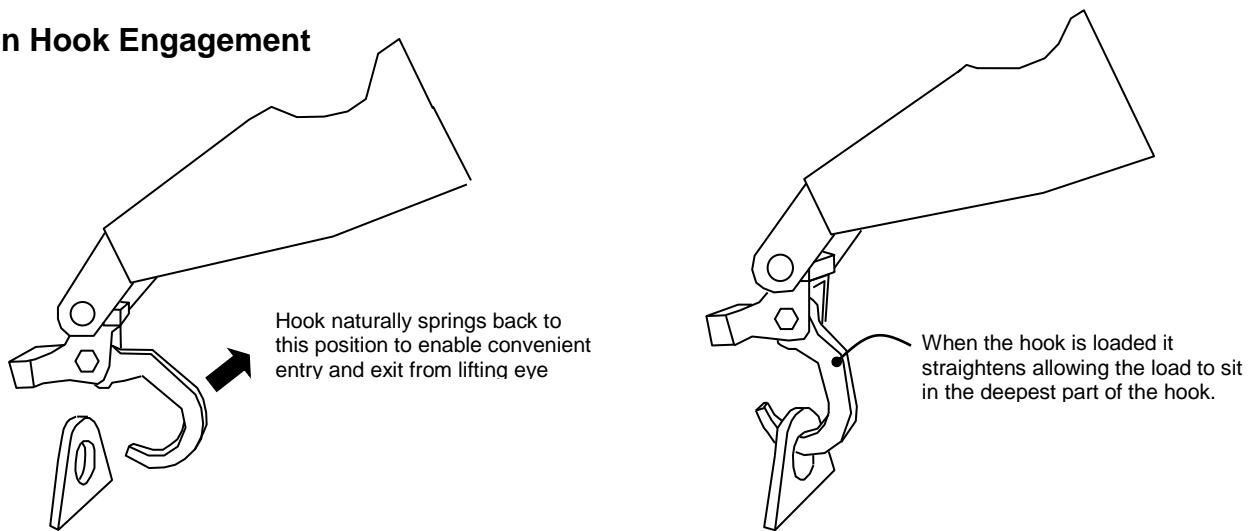

Side on Hook Engagement

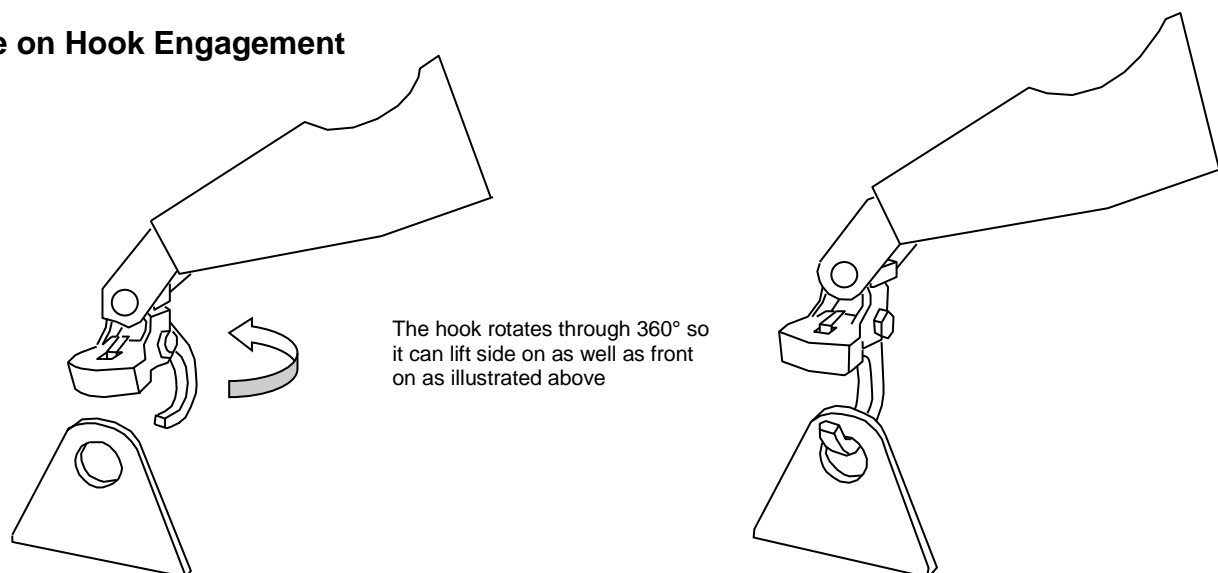

Removing a hook is a two stage process-

1. Lift the handles to take load off the hook
2. Guide the hook back out of the lifting eye by laterally manipulating the handles

3.2.6b Hook Operation

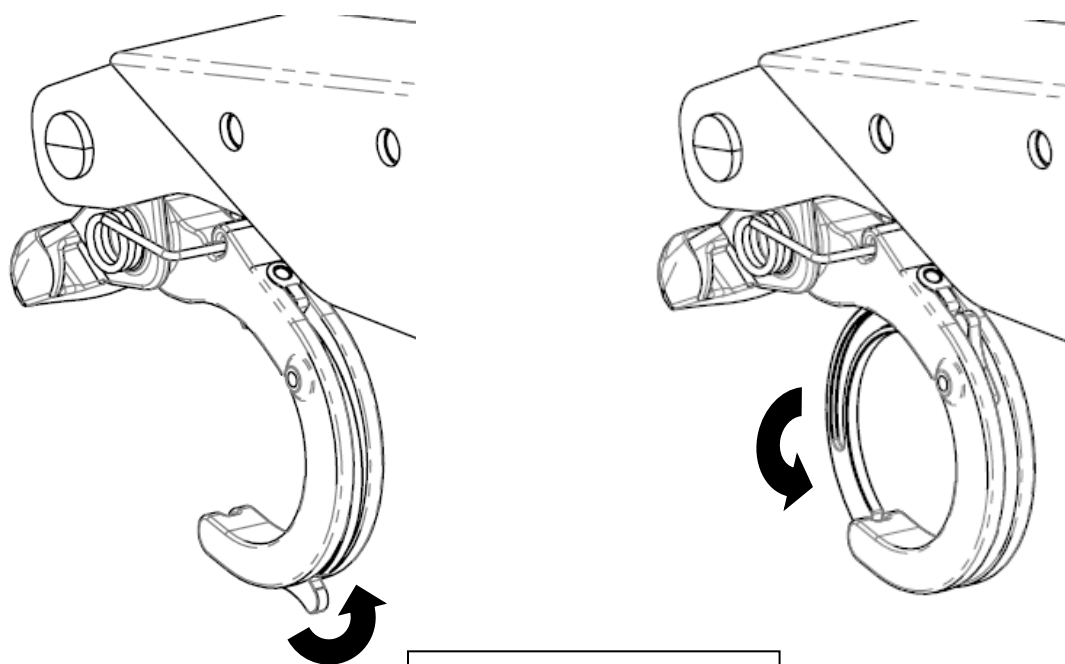

Push the tab upwards and the spring on the top of the hook will lock into the groove on the catch

In circumstances where the hook must be locked for safety, a safety catch is available to use.

TO RELEASE, PUSH THE TAB IN THE REVERSE DIRECTION

3.2.7 Operating Brakes

- Brakes work like the park brakes on a car
- Once engaged, it will automatically stay on until released

Brake Disengaged

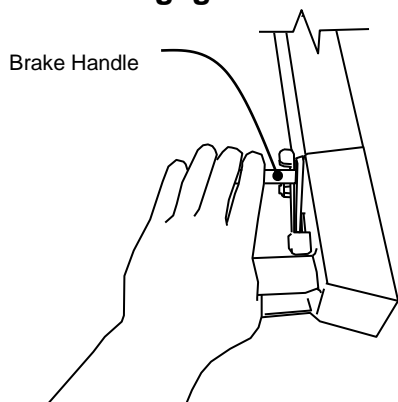

Brake Engaged

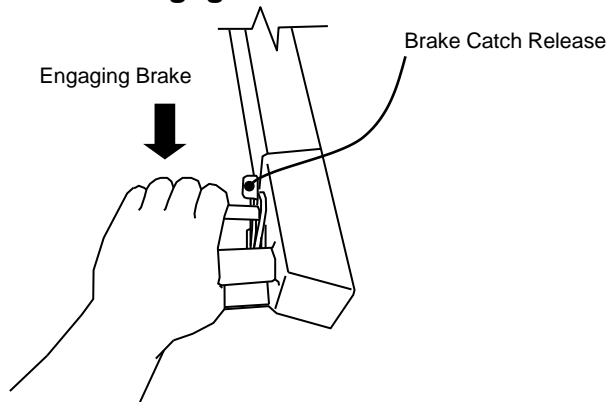

Releasing Brake

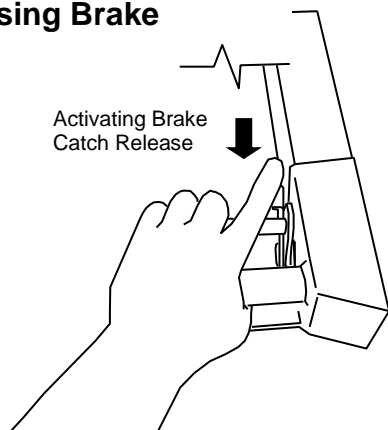

- Brakes can be easily applied by pulling the brake handle towards the handle bar
- Release brakes by pressing down the brake release lever

Direction of uncontrolled load movement with BRAKES ON

Direction of uncontrolled load movement with BRAKES OFF

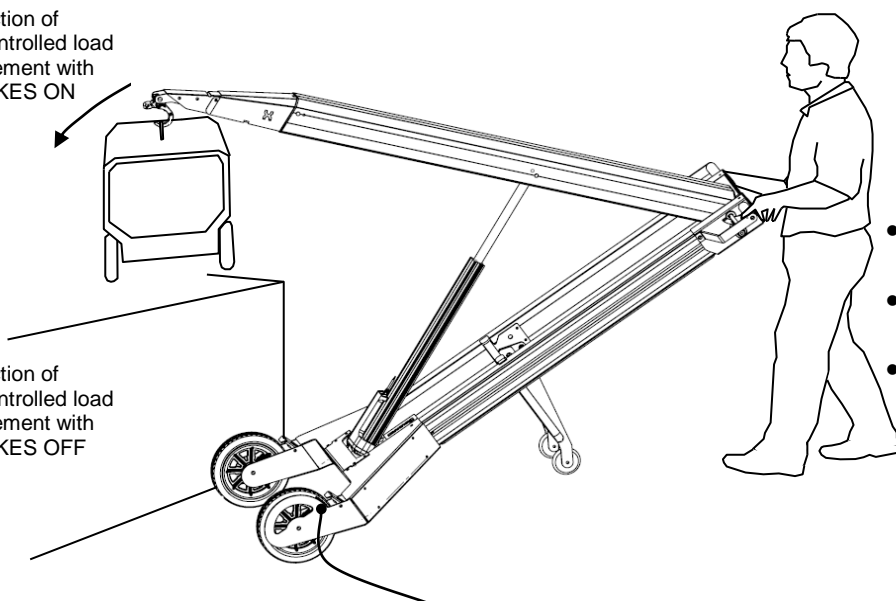

- In this loaded-reach position the brakes must be applied.
- When 'reaching' load at height, always apply brakes.
- Applying the brakes fixes the pivot point at the wheel position and improves leverage on the load.

Locking the front wheels with the brakes turns the device into a 'first class lever' improving controllability of load in loaded high-reach situations

3.2.8 Ground Conditions

- Firm ground is required for loading and unloading with the PHT-140 device. Concrete, asphalt, rolled road base are suitable.
- Small stones or bumps can reduce the ability to manoeuvre the loaded device into a good position for executing a lift.
- If sloped, try to approach lift up or down hill – not across the slope. For more information on this, see 'SLOPE GUIDE section 5'.
- For transporting the load across ground, firm and smooth ground is required.
- If ground is not firm and smooth, it may be more convenient to unload and use other means to transport the load across ground. For example, some small machinery has pneumatic wheels built in which can be more appropriate for transportation across earth or turfed areas.
- When unloading, beware of any features of the ground such as pot holes which could cause sudden movements or unexpected resistance or shifts of balance.

3.2.9 Transporting load across ground

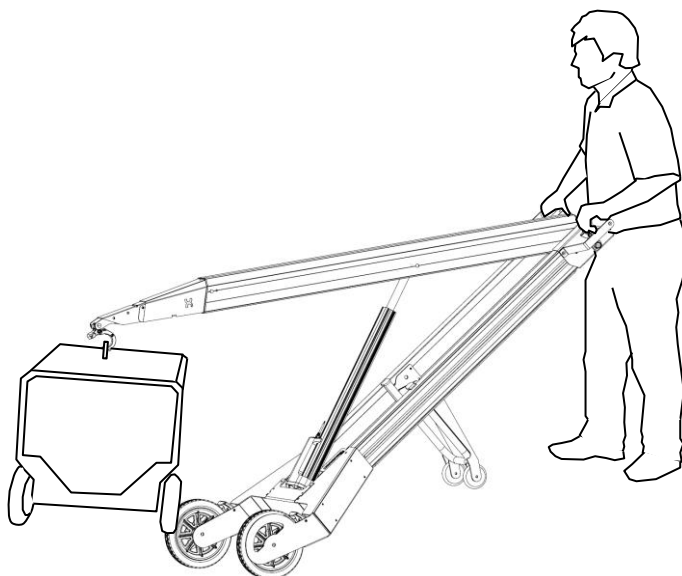

- Keep the load low at all times while moving across the ground in a *hands neutral position* (defined in section 3.2.5 and 4.0).
- The wheels are designed for hard smooth surfaces.
- If moving on a slope, obey the guides shown in the 'SLOPE GUIDE' section 5 of this document.
- Only carry a load in a forward direction.
- Consider using the wheels already fixed to the unit which might be more appropriate for rough or soft ground.
- Don't take hands off the machine while loaded.

3.3 Lift Technique

3.3.1 Raising & lowering load

- These figures show different load heights in the *hands neutral position*

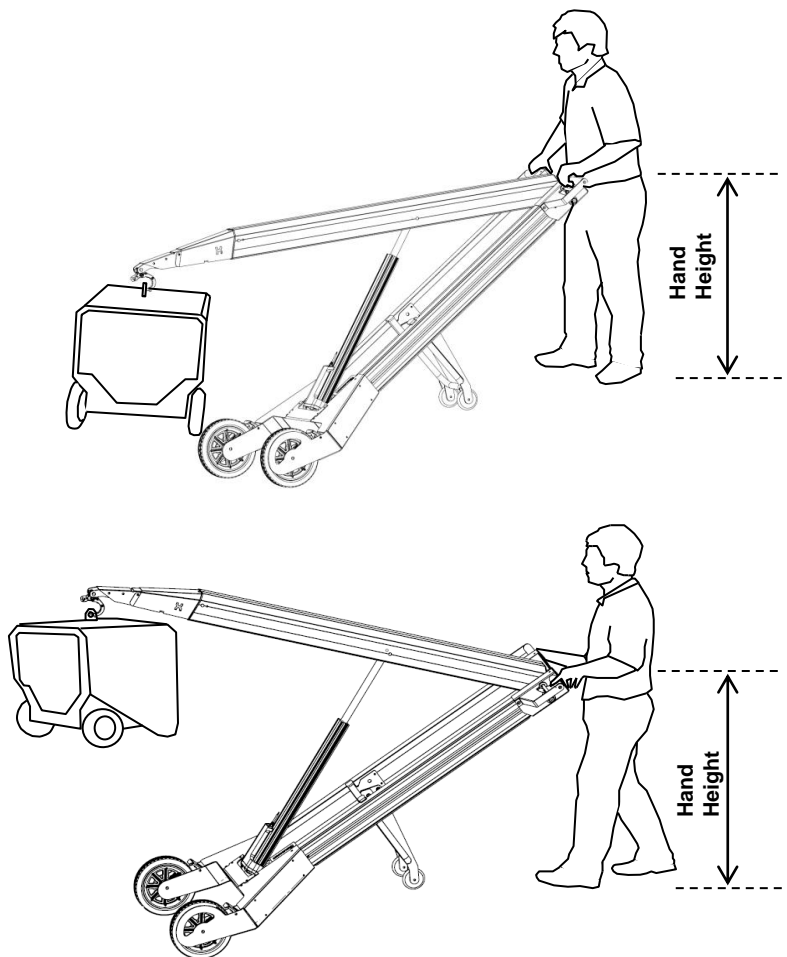

- Keep device stationary while raising load.
- Once load height clear of platform, carefully move wheels closer.
- Apply brakes and begin the unload procedure.
- To lower load, apply procedure in REVERSE.

Note - as load is lifted higher, the *hands neutral position* requires hands to be higher from ground

3.3.2 Loading & Unloading at height

- Be certain the platform can take the weight of the load.
- Only attempt to transfer the load to an elevated platform that can take the weight.
- Have a firm footing – device can pull user towards load in high load, high reach situations.
- Examine ‘LOAD AND REACH DATA’ section 4 and beware that manageable limits of the load can be dependent on user (described in section 4).
- Train and practice on loads of mid-range weight.
- Always move handles slowly with heavy load at height.

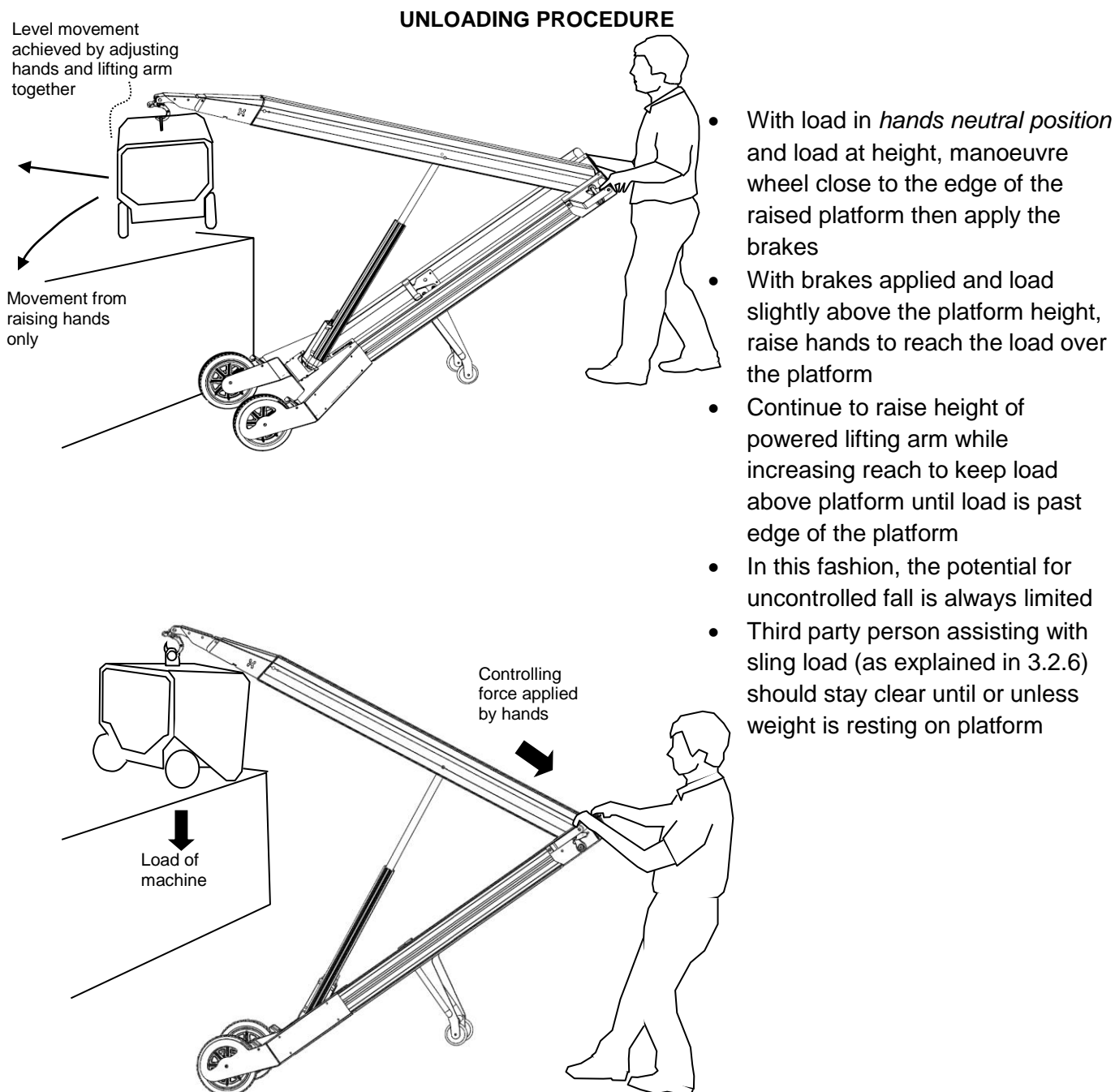

- With load in *hands neutral position* and load at height, manoeuvre wheel close to the edge of the raised platform then apply the brakes
- With brakes applied and load slightly above the platform height, raise hands to reach the load over the platform
- Continue to raise height of powered lifting arm while increasing reach to keep load above platform until load is past edge of the platform
- In this fashion, the potential for uncontrolled fall is always limited
- Third party person assisting with sling load (as explained in 3.2.6) should stay clear until or unless weight is resting on platform

- **Note:** if simply raising handles and not operating lifting arm, the load will travel in a downward arc. Therefore both actions are needed to keep load just above the lift platform

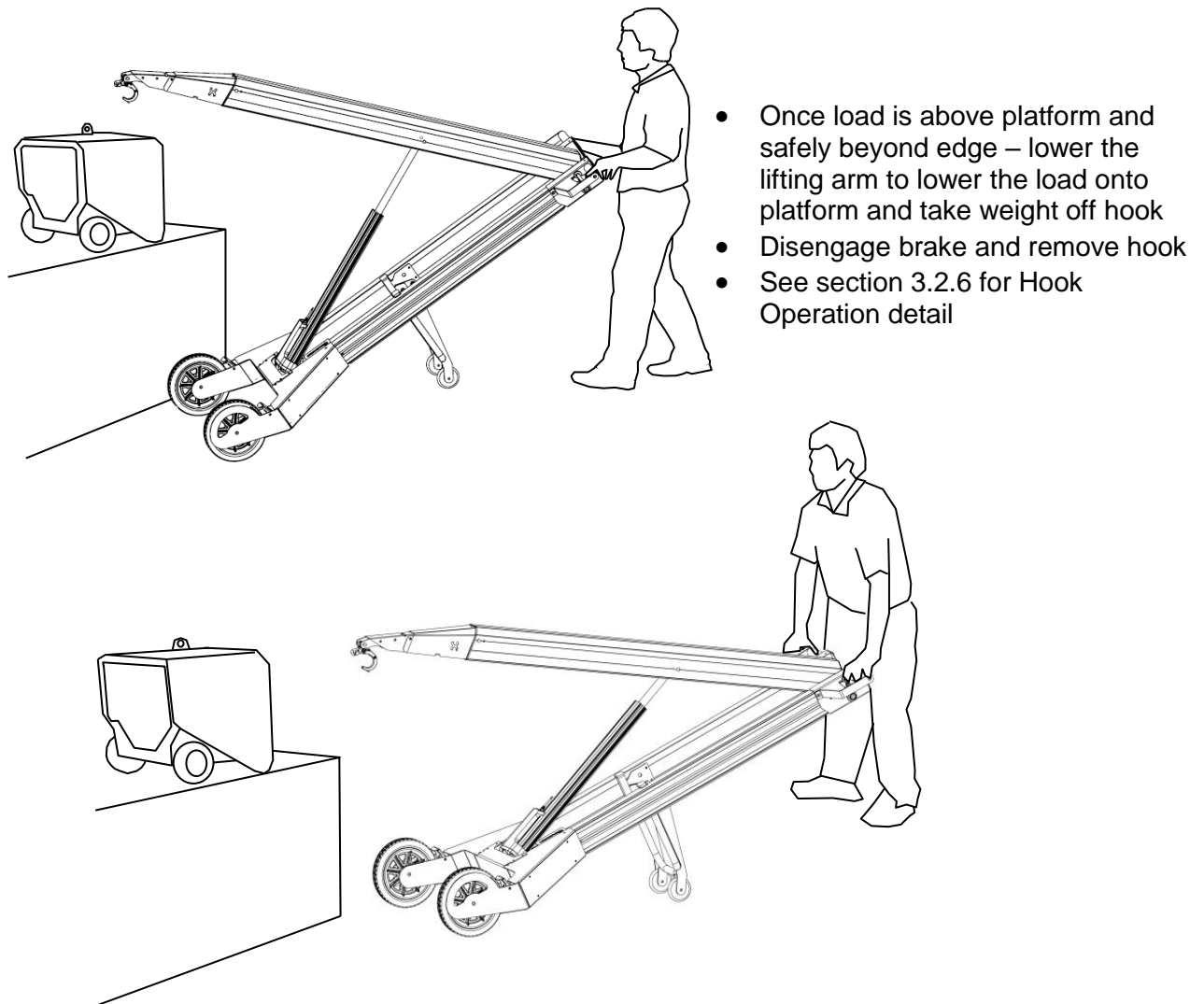

- Once load is above platform and safely beyond edge – lower the lifting arm to lower the load onto platform and take weight off hook
- Disengage brake and remove hook
- See section 3.2.6 for Hook Operation detail

Figure shows backing device away from unload procedure whilst lowering the lifting arm

REVERSE SEQUENCE – LOADING AT HEIGHT

- Once load is engaged on hook, lower handles whilst also lowering the arm in order to maintain minimal load height above the platform.
- Only release the brake once the load is in a **Hands Neutral Position** (as described in section 4- Load and Reach Data)
- Then back the load up only as much as necessary to fully lower the load and clear the platform using the procedure described in 3.3.1

3.3.3 Increased Risk Position

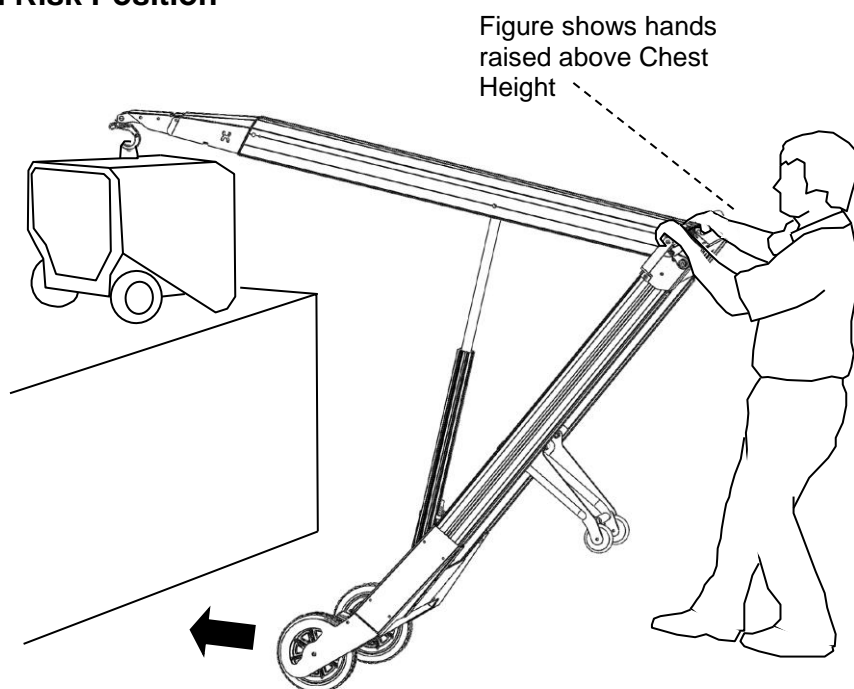

If wheels were closer to the platform the operator would require less Reach

- The above position shows extended reach and hands raised above chest height.
- It is in this region that heavy load can become unmanageable because of the force required to control the handles.
- See 'LOAD AND REACH DATA' section 4 for more details (Beware that manageability limit of load size and reach can be dependent on user).
- There should be no reason to use this position because only enough reach is required to position along beyond the edge of the platform.
- If procedure performed properly, edge of the platform should be close to vertically in line with the front of the wheels.
- If wheels are too far from edge of the platform, resume *hands neutral position* and place wheels closer to perform then perform operation again. This time requiring less reach.

3.3.4 Topple Scenario

In the event of loss of control of load while reaching out-

- Allow load to fall forward onto platform, if possible try to control what should be a fall of a short distance.
- If control is completely lost, let go of handle and step back away from the device and platform in case load comes free of hook and falls off platform

3.4 Charging

- The 18V Lithium Ion battery can be recharged with an external charger.
- Top up battery regularly.
- Full charge from the low battery level will take 2 hours.
- A full battery will sustain around 45 load and unload cycles at 90kg.
- The external charger will not over charge battery – It has built-in cut off.
- Charge on 240V lead protected by Residue Current Device.
- If battery after charging won't reach 18.4V, then it may need to be replaced.

- DO NOT leave machine switched ON when it is not in use as this will drain the battery and effectively destroy it.

3.5 Power failure unload procedure

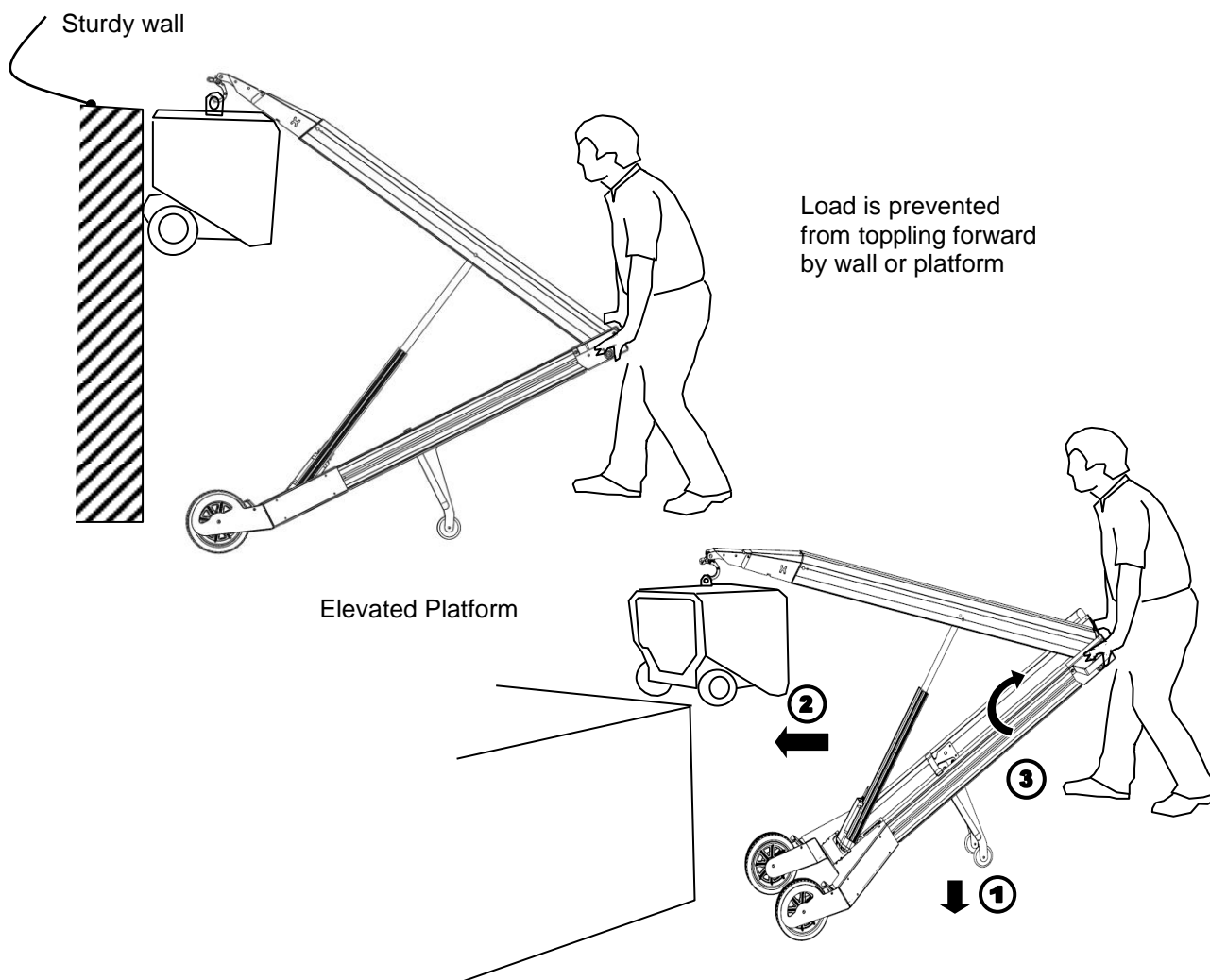

NOTE: In most cases, it could just be that the battery is flat and replacing the battery would solve this issue.

If linear actuator or power fails preventing the ability to lower the Powered Lifting Arm, follow these instructions:

- If lifting arm is low enough, place load on the ground and disengage it, if lifting arm is close to a bench or platform, place load on the platform and disengage it.
- Otherwise need to stabilise the loaded device so you can temporarily leave the device unattended.
- **1.** Put the back wheels on the ground and **2.** Push the load against a wall or the edge of an elevated platform and **3.** put the brakes ON – this will stop the load being able to tip forward, making it stable enough to take hands off the controls.
- Beware of extra risk associated with rearward topple if on an upward slope. In this case, lean with rear wheels off ground the load into the platform so the load is strongly biased to fall forward into platform then put on brakes.
- With the device stabilized, the objective now is to prepare to remove the load from machine if possible.
- Depending on circumstances, the following strategies may be convenient
 - Get more people for a three man lift
 - Get a suitable height platform and position it so the load can be dropped off without needing to lower the lifting arm
 - Get a forklift and disengage load onto a pallet
- Alternatively, make arrangements for such strategies.
- Once device is unloaded, get it repaired by a qualified person.

3.6 Transport and Storage

- The device conveniently folds to a flat state for storage and transport.
- It is designed to be easily transported in utility vehicles and vans.
- If leaning against walls for storage like a step ladder, be sure that it can't fall and cause injury or damage.
- When loading onto a utility vehicle, first lean the handles on the tray edge then lift wheels from ground and slide.
- Lift using good posture. The wheels end of the device weighs about 25kg although it will feel less depending on support from tray.
- Device will not be damaged by getting wet from rain while in yard or on the utility vehicle. Do not store upside down in vehicle, do not store in rain.
- Do not pressure wash.
- Do not leave machine outdoors. Avoid getting it wet.

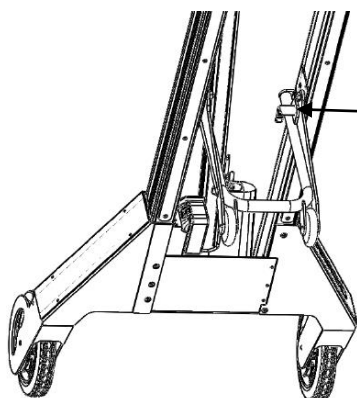

- Rear wheels fold out and lock into place
- To fold away apply plunger and engage it into hole positions allocated

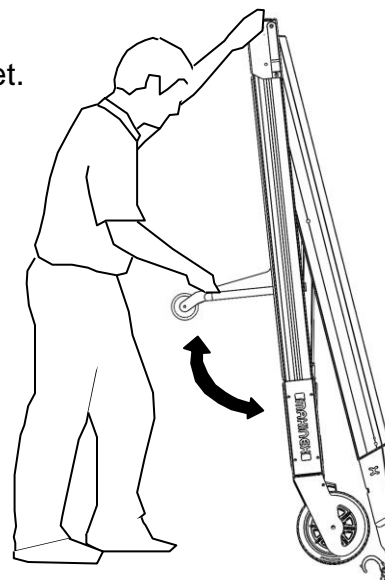

- Lifting arm folds up and down as operated by thumb switch

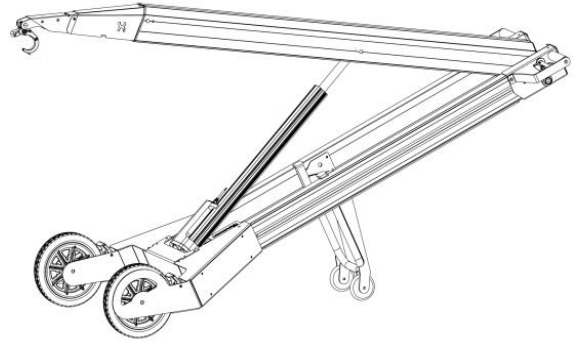
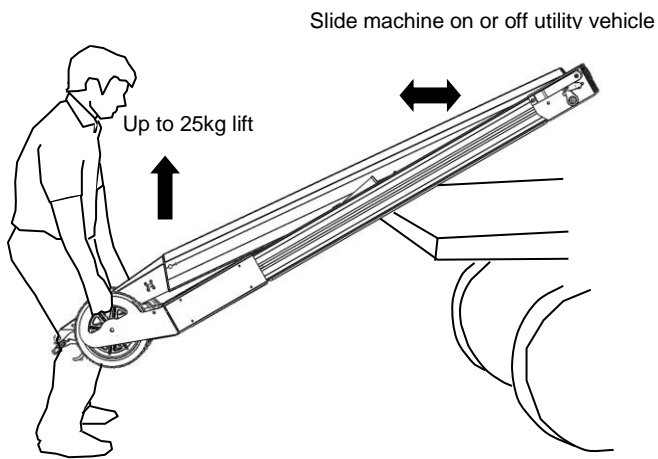

- When using device on a day to day basis – time and battery power is saved by leaving the device as illustrated between uses.

4. LOAD AND REACH DATA

Unloaded, Pre-Pick Up

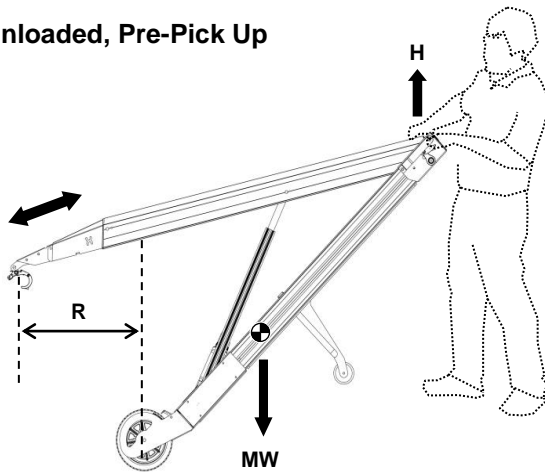

- MW** Weight of PHT-140 device (40kg)
- H** Balancing Force applied by Hands
- L** Weight of the Load (up to 140kg)
- R** Reach – horizontal distance from wheel axle to hook

- With no load engaged, to lift the handles and adjust the reach the user must overcome the weight of the machine.
- The amount of force H is about 13kg

Loaded Hands Neutral Position, Transporting or Lifting, No brakes applied

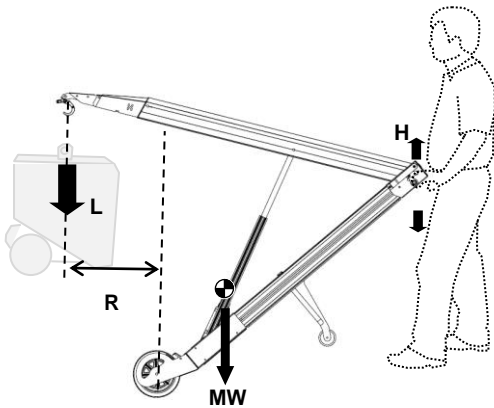

- This is called the '**Hands Neutral Position**' where the weight of the load balances against the weight of the PHT-140 machine leading to little (neutral) weight in the users hands.
- Force applied by the hands is to adjust height and maintain balance of load. It can vary as force applied up or down but tends to be less than 10kg either way.

Reach Out at height, Loaded, Brakes applied

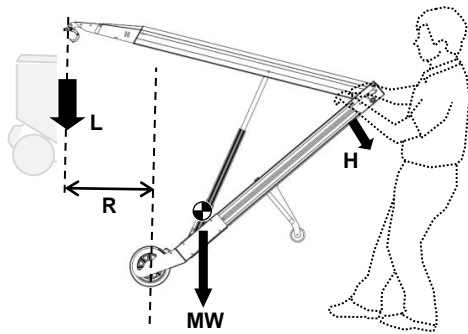

- With brakes applied H is no longer Up and Down but is pivoting about the front wheels – giving better control

Variation of H with different Load (L), Fixed Reach (R)

L	50kg	80kg	110kg	145 0kg
H	5kg	15kg	23kg	32kg
R	60cm	60cm	60cm	60cm

Note about user comfort limit.

Each user must limit the load and reach combination to what they can manage. With a heavy load, a user may only be able to comfortably reach out so far. With a lighter load the same user may be comfortable reaching out further.

Extended Reach Out, Loaded, Brakes applied >CAUTION<

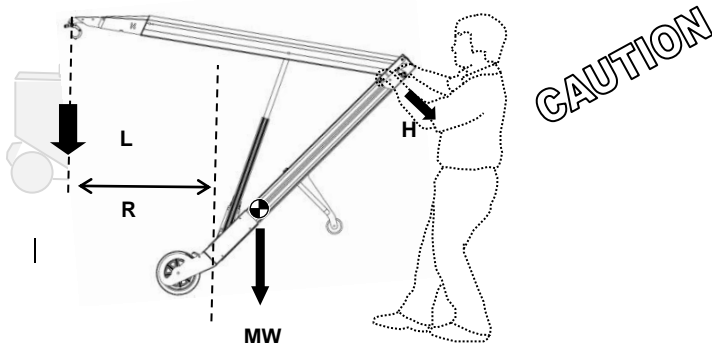

Increased risk of forward topple

- In this position with hands raised above the chest the body's reaction tends more toward pulling the handles rather than holding the handles down.
- At a point the user can be pulled off balance

Variation of H with different Load (L), Fixed Reach (R)

L	50kg	80kg	110kg	150 kg140kg
H	9kg	20kg	32kg	39kg
R	75cm	75cm	75cm	75cm

Possible user comfort limit!

5. SLOPE GUIDE

Loading / unloading downhill

Max - 4% or 3 degrees

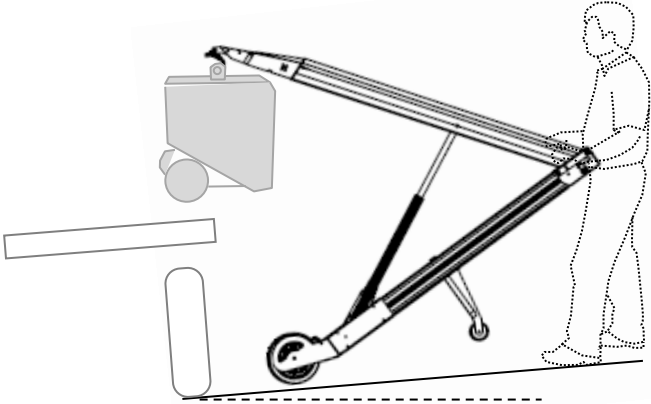

Loading / unloading uphill >CAUTION<

Max - 2% or 1 degree –VIRTUALLY FLAT

- rear wheel 18mm lower than front when grounded

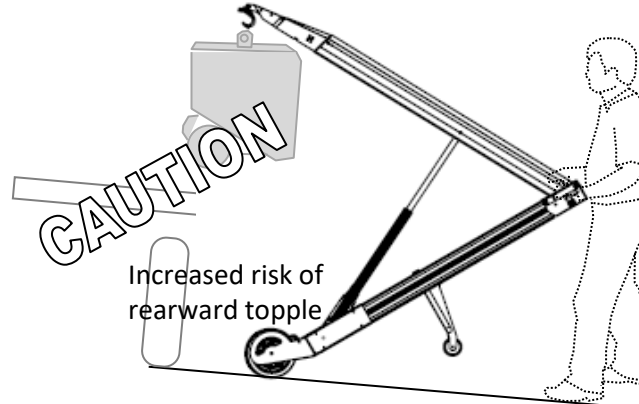

Loading / unloading across-hill >CAUTION<

Max - 2% or 1 degree –VIRTUALLY FLAT

- One wheel 13mm higher than other

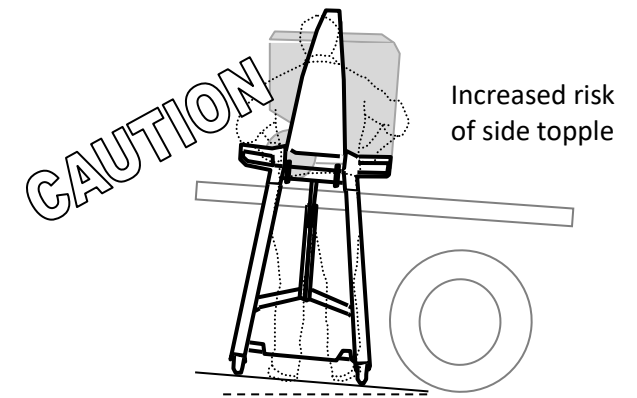

Transporting downhill

Max - 8% or 5 degrees

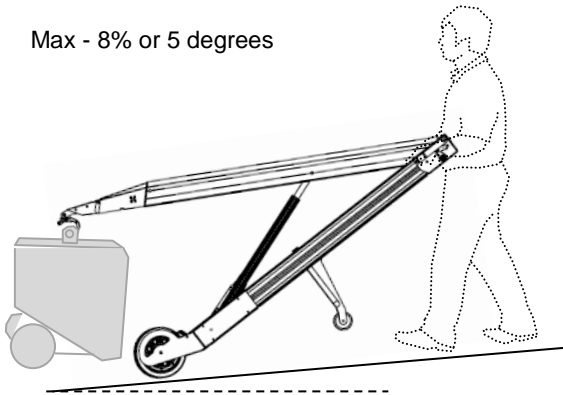

Transporting uphill

Max - 8% or 5 degrees

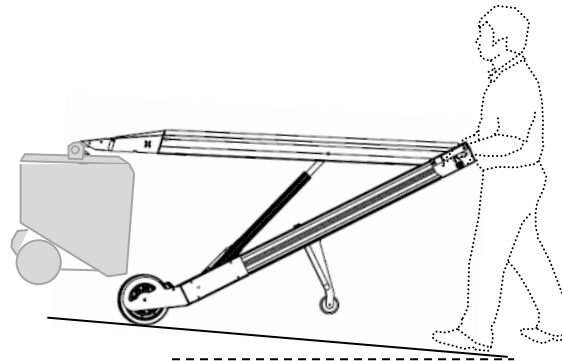

Transporting across-hill

Max - 6% or 3.5 degrees

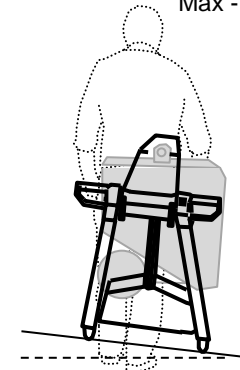

- These slopes are for recommendations maximum slope for maximum load
- As a guide for 50% less than maximum load, add 50% to the max slope

SLOPES SHOWN ARE NOT TO SCALE

6. QUICK REFERENCE HAZARD ASSESSMENT

PRODUCT RISK / HAZARD ASSESSMENT TABLE			
PRODUCT NAME:	PHT-140	Assessment Carried Out	Michael Chen
MANUFACTURER:	MAKINEX	Document Revision Number:	002
OPERATOR COMPETENCY:	PLANT LICENCE NOT REQUIRED	Date Created:	21/01/2016

No:	TYPE / NATURE OF RISK or HAZARD		LIKELIHOOD	CONSEQUENCE	RISK LEVEL	CONTROL ACTION
1.0	CRUSH/PINCH	1.1 UNSTABLE GROUND CAUSING LOAD TO TOPPLE -SIDE WAYS FROM HEIGHT	2 LIKELY	3 MINOR	2 MEDIUM	- KEEP CLEAR OF BYSTANDERS - FOLLOW SAFE OPERATING PROCEDURE
		1.2 UNSTABLE GROUND CAUSING LOAD TO TOPPLE -IN TRANSPORT SCENARIO	2 LIKELY	4 NEGLIGIBLE	2 MEDIUM	- KEEP CLEAR OF BYSTANDERS - FOLLOW SAFE OPERATING PROCEDURE
		1.3 USER LOSS OF CONTROL CAUSING LOAD TO TOPPLE FORWARD	2 LIKELY	3 MINOR	2 MEDIUM	- KEEP CLEAR OF BYSTANDERS - FOLLOW SAFE OPERATING PROCEDURE
		1.4 USER LOSS OF CONTROL CAUSING LOAD TO TOPPLE TOWARDS USER	3 UNLIKELY	3 MAJOR	2 MEDIUM	- KEEP CLEAR OF BYSTANDERS - FOLLOW SAFE OPERATING PROCEDURE
		1.5 FAILURE OF MACHINE STRUCTURE CAUSING LOAD TO FALL	3 UNLIKELY	3 MINOR	3 LOW	- KEEP CLEAR OF BYSTANDERS - FOLLOW SAFE OPERATING PROCEDURE
		1.6 BUMPS IN GROUND CAUSING LOSS OF CONTROL	2 LIKELY	3 MINOR	2 MEDIUM	- STEER AWAY FROM THE BUMPS - CHECK AND GET RID OF BUMPS IN WORKPLACE
		1.7 STEEP GROUND CAUSING LOSS OF CONTROL	3 UNLIKELY	3 MAJOR	2 MEDIUM	- AVOID SLOPES - FOLLOW SAFE OPERATING PROCEDURES - AFTER OPERATION OR ,WHEN NOT IN USE; THE BRAKE IS TO BE APPLIED
		1.8 UNBALANCED LOAD CAUSING TO TOPPLE FORWARD	3 UNLIKELY	3 MINOR	3 LOW	- CORRECT THE HOLDING POSITION BETWEEN THE WAIST AND CHEST - FOLLOW SAFE OPERATION PROCEDURE - CHECK AND FOLLOW USER MANUAL
		1.9 HAND PINCHING AT THE NIP POINT	3 UNLIKELY	3 MINOR	3 LOW	- USE BOTH HAND DURING OPERATION - FOLLOW SAFE OPERATING PROCEDURES - KEEP CLEAR OF BYSTANDERS
		1.10 OPERATOR DOES NOT LOCK THE FOLD WHEEL PROPERLY CAUSING THE MACHINE TO COLLAPSE	2 LIKELY	3 MINOR	2 MEDIUM	- CHECK FOLD WHEEL BEFORE USE - CHECK FOR CORRECT OPERATION BEFORE USE - CHECK IF THE PLUNGER FEEDS IN THE HOLE COMPLETELY BEFORE USE - CHECK IF THE PLUNGER FEEDS EASILY INTO THE HOLE
		1.11 BRAKE NOT WORKING PROPERLY CAUSING ACCIDENT WHILE OPERATING	4 VERY UNLIKELY	4 NEGLIGIBLE	3 LOW	- CHECK AND FOLLOW USER MANUAL - FIX THE ALIGATOR CLIP, TIGHTEN IF NEEDED - CHECK THE BRAKE CABLE FOR WEAR AND BROKEN STRANDS, IF FOUND REPLACE IMMEDIATELY.

2.0	STRAIN	2.1	LOADING PHT-140 ONTO UTE CAUSING BACK INJURY	3	UNLIKELY	2	MAJOR	2	MEDIUM	<ul style="list-style-type: none"> - CHECK AND FOLLOW USER MANUAL - ALWAYS LIFT CLEAR OF BYSTANDERS
		2.2	BATTERY DISCHARGED AFTER LIFTING THE LOAD LEAVING THE OPERATOR STRANDED	3	UNLIKELY	3	MINOR	3	LOW	<ul style="list-style-type: none"> - ENSURE BATTERY IS FULLY CHARGED BEFORE OPERATING. - CHECK THE BATTERY FOR WEAR SIGNS; DO NOT USE IF LEAKING - IN CASE OF POWER FAILURE WHILE THE LOAD ON, FIND A STURDY WALL AND LEAN IT NEXT TO THE WALL OR, FIND AN ELEVATED PLATFORM TO PLACE THE LOAD ON IT.
3.0	ELECTRICUTION	3.1	FAULTY LEAD/SWITCH ON MACHINE	4	VERY UNLIKELY	3	MINOR	3	LOW	<ul style="list-style-type: none"> - PERIODIC SERVICE OF MACHINERY - DO NOT USE DAMAGED OR SEVERED LEADS,CHECK BEFORE EACH USE - DO NOT WASH THE MACHINE WITH PRESSURE WASHER
		3.2	FAULTY LEAD ON CHARGER	4	VERY UNLIKELY	1	FATALITY	2	MEDIUM	<ul style="list-style-type: none"> - DO NOT CHARGE OUTDOORS OR IN WET ENVIRONMENT - CHARGE THROUGH RED PROTECTED CIRCUIT - PERIODIC SERVICE OF MACHINERY - DO NOT USE DAMAGED OR SEVERED LEADS,CHECK BEFORE EACH USE - DO NOT WASH THE MACHINE WITH PRESSURE WASHER

NOTES:

- > THIS PRODUCT HAS BEEN DESIGNED AND MANUFACTURED AS A HAND TRUCK WITH A POWERFUL LIFTING ARM ONLY
- > THIS DOCUMENT HAS BEEN PREPARED ACCORDING TO GUIDELINES AND RECOMMENDATIONS FOUND IN:
 1. 'HAZPAK' PRODUCED BY THE WORK-COVER AUTHORITY AND
 2. THE AUSTRALIAN STANDARDS 4024.1.4/5 - 1996 "SAFEGUARDING OF MACHINERY - PART 1: GENERAL PRINCIPLES AUSTRALIAN STANDARD, AS/NZS 3760 IN-SERVICE SAFETY INSPECTION AND TESTING OF ELECTRICAL EQUIPMENT.

<p>"LIKELIHOOD LEVEL" REFERS TO THE PROBABILITY OF AN EVENT HAPPENING. THE FOLLOWING SCALE HAS BEEN USED TO DESCRIBE THE LIKELIHOOD OF A DEFINED RISK / HAZARD EVENT OCCURING DURING NORMAL OPERATION OF THE EQUIPMENT. NOTE THAT LIKELIHOOD EVALUATION IS QUALITATIVE AND BASED ON BEST ESTIMATION VIA CONSULTATION AND EXPERIENCE:</p> <ol style="list-style-type: none"> 1. VERY LIKELY 2. LIKELY 3. UNLIKELY 4. VERY UNLIKELY 	<p>"CONSEQUENCE" REFERS TO THE SEVERITY OF INJURY CAUSED DUE TO AN EVENT OCCURING, USING THE FOLLOWING SCALE AS DEFINED BY THE "HAZPAK" DOCUMENT:</p> <ol style="list-style-type: none"> 1. FATALITY = INJURIES RESULT IN DEATH 2. MAJOR = NORMALLY IRREVERSIBLE INJURIES 3. MINOR = REVERSIBLE INJURIES REQUIRING SEVERAL DAYS OFF 4. NEGLIGIBLE = ABLE TO BE TREATED USING FIRST AID 	<p>"RISK LEVEL" REFERS TO THE SEVERITY OF A RISK BASED ON THE "LIKELIHOOD LEVEL" AND "INJURY LEVEL".INHERENTLY, AS THE CONSEQUENCE INCREASES IN SEVERITY, RISK INCREASES - EVEN WHEN LIKELIHOOD IS LOW - THE FOLLOWING SCALE HAS BEEN USED:</p> <ol style="list-style-type: none"> 1. HIGH = POTENTIAL DEATH, PERMANENT DISABILITY, OR MAJOR STRUCTURAL DAMAGE. 2. MEDIUM = POTENTIAL TEMPORARY, DISABILITY, OR MINOR STRUCTURAL DAMAGE. 3. LOW = POTENTIAL INCIDENT THAT HAS THE POTENTIAL TO CAUSE PERSONS TO REQUIRE FIRST AID.
---	--	--

7. SAFETY AND INSTRUCTION DECAL

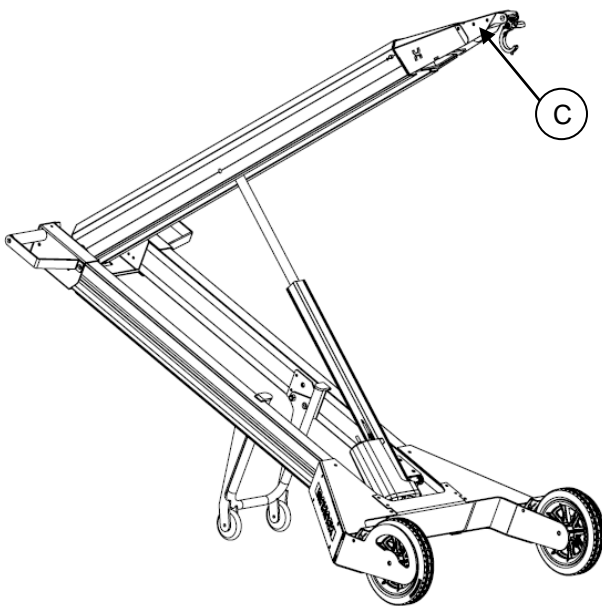

A

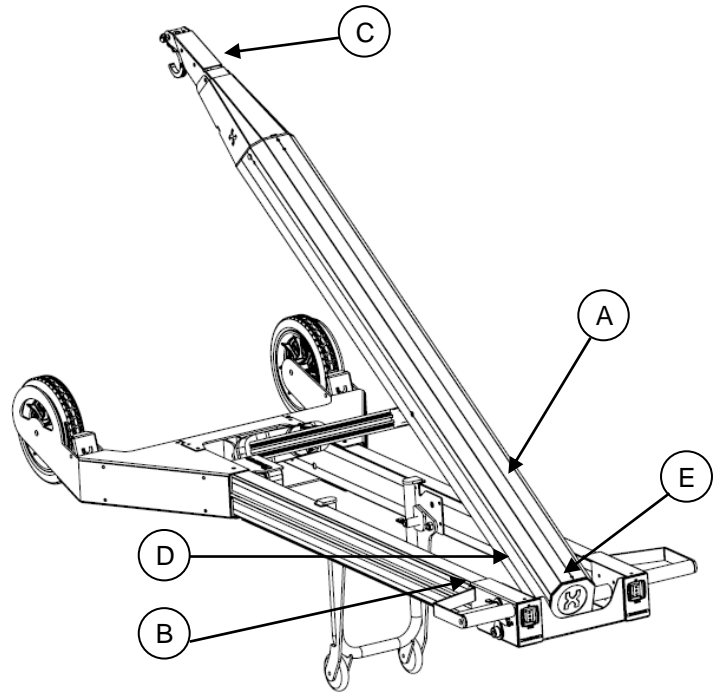

E

MAKINEX POWERED HAND TRUCK PHT-140

CAUTION

- Operator **MUST** be skilled and trained in operation
- ALWAYS keep hands on handles while machine is loaded
- ALWAYS lower or raise the load while wheels are stationary
- ALWAYS have load at low height when moving across the ground
- ALWAYS use the brakes while engaging or disengaging the load at height
- ALWAYS move handles slowly with heavy load at height
- Charge battery daily

OPERATING INSTRUCTIONS

CONTROL REACH

LIFT or LOWER handles to vary hook REACH

CONTROL HEIGHT

USE thumb switch to control hook HEIGHT

SPECIFICATIONS

SWL 140kg/308lbs max	Lift range hook height 0 - 1.9m/6ft 2in fork height 0-1.55m/5ft 1in
Power 18v 4Ah Lithium Ion battery with LED power level indicator	Machine weight 44kg/97lbs
12v 20A linear actuator	Weather resistance Store Indoors
2 hours full charge	Truck Type designations Type E

WARNING

Operator **MUST** be skilled and TRAINED in operation!
READ MANUAL AND WATCH TRAINING VIDEO BEFORE USE

Go to Makinex.com for more production information
Patent Pending, Designed in Australia, Made in China

Scan QR code for more information

B

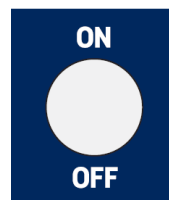

C

WLL
140kg/
308lbs

D

MAKINEX CONSTRUCTION PRODUCTS

Makinex Pty Ltd
15 Waltham Street
Artarmon NSW 2054 Australia
P +612 9460 8071
W makinex.com.au

CE

MODEL	PHT-140
SERIAL NUMBER	12000
YEAR OF CONSTRUCTION	FEB 2016
MASS (kg/lb)	40kg 88lb
RATED VOLTAGE	18v
RATED CURRENT	24 amp
MAXIMUM HEIGHT (m/ft)	1900mm 6ft 2in
SAFE WORKING LOAD (SWL)	140kg 309lb

8. TECHNICAL DATA AND SPECIFICATIONS

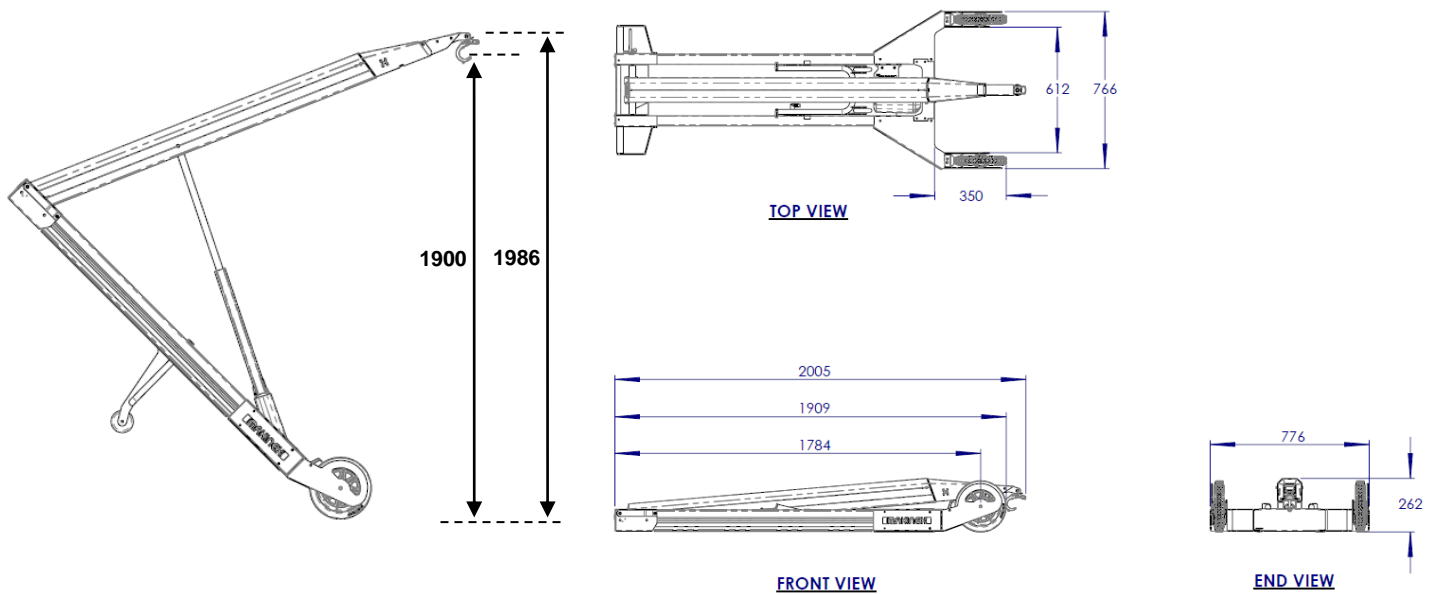

MACHINE SPECIFICATIONS	
Lift Capacity	Up to 140kg / 308lbs
Linear Actuator	12V 25Amp
Hook Height Range	Ground to 1.9m
Weight of Machine	Total 40kg <ul style="list-style-type: none"> ▪ Handle end - 15kg ▪ Wheel end - 25kg
Battery	18V 4AH rechargeable power tool battery
Battery Capacity	40-50 Operations – (load or unload average 90Kg load to or from 1.1m height)
Weather Resistance	Do not use or store in wet conditions, Store indoors
Charge Method	Battery Charger for the 18V power tool battery (AUS version) Different power plug for USA/EU
Speed	Average lift 15 seconds

CHARGER SPECIFICATIONS

Charger Type :	For Li-ion Battery(NI-CD/ NI-MH need extra adapter)
Input Voltage :	100V-240V
Input Frequency:	50-60HZ
Output Voltage:	16.8V / 21.0V
Output Current:	1.5A /3A
Max Output Power:	31.5W
Storage Temperature:	-20℃ - 85℃,
Operating Temperature:	0℃~ -40℃
Relative Humidity:	5%(0℃)~90%(40℃),
Efficiency:	80%
Charger method:	CA-CV(contant current- contant voltage)
Replace Part No.:	DC18RA DC18RC
Fit battery model:	BL1430, BL1415, BL1830, BL1840,BL1850,BL1815
Turn light current:	200mA
Certification:	CE
Plug:	EU, USA, Au, UK
Dimension:	185x155x100mm
NW:	600g
GW:	720g
LED indicator	<80% : green light
	<80%<100% : green light +red light
	=100%: green light
	Red light and green light blink: Battery broken
Note:	1. This battery is designed for makita battery
	2. Keep aways from children
	3. Used indoor only
	4. Do not insert cracked/ damaged battery into charger
	5. Do not probe with conductive metal object during charging
	6. Keep away from water

Image:



9. LIMITED WARRANTY

In order to take advantage of the MAKINEX limited warranty, you must have maintenance performed according to the schedule (contained in relevant owner's manual supplied with this product), by an authorised MAKINEX dealer or MAKINEX service technician. You are free to have your MAKINEX product serviced by any suitably qualified mechanic or electrician (depending on the mechanical or electrical requirement) and this will not affect your statutory warranties, however, failure by the owner to have the recommended servicing carried out by an authorised MAKINEX dealer/service technician means that you cannot take advantage of the MAKINEX limited warranty.

In order to ensure your safety, we strongly recommend that you only use an authorised MAKINEX dealer for servicing. Only authorised MAKINEX dealers have access to all the special tools, technical information, parts and training required to maintain your MAKINEX product in peak operating condition.

MAKINEX warrants each new Powered hand truck to be free from defects in material and workmanship under normal domestic and industrial use and service for the period specified below, conditional to the limitations and exclusions printed on this page. This warranty applies only to new MAKINEX pressure washers distributed by us and by our authorised MAKINEX dealers.

Our goods come with guarantees that cannot be excluded under the Australian Consumer Law. You are entitled to a replacement or refund for a major failure and compensation for any other reasonably foreseeable loss or damage. You are also entitled to have the goods repaired or replaced if the goods fail to be of acceptable quality and the failure does not amount to a major failure.

WARRANTY: (Ex-factory/ Reseller premise)

MAKINEX warrants to the original purchaser:

- Frame and Jib will be free of defects in material and workmanship for a period of one (1) year from the original date of purchase.
- Linak Actuator are subject to 1 year warranty
- 1 year warranty on Batteries and Chargers (Misuse and over discharge of the battery is not covered under warranty)

Warranty exclusions:

This warranty does not cover the following repairs and equipment:

Normal Wear

This warranty does not cover repair when normal use has exhausted the life of a part or the equipment as a whole.

Installation, Use and Maintenance

This warranty will not apply to parts and/or labour if the Powered hand truck is deemed to have been misused, neglected, involved in an accident, abused, loaded beyond the Powered hand truck's limits, modified, installed improperly.

Other Exclusions

This warranty excludes:

- Cosmetic defects such as paint, decals, etc.
- Wear items such as wheels, brake components
- Failures due to acts of God and other force majeure events beyond the manufacturer's control.
- Problems caused by parts that are not original MAKINEX parts.

Responsibility of the consumer under this Limited Warranty:

- Proper maintenance and safety checks need to be performed before operation of the machine.
- Strict adherence to the maintenance daily checks and schedule with proof of scheduled maintenance service required by an authorised agent or qualified mechanic and/or electrician.
- Maintenance services are not covered under warranty.
- It is the consumer's responsibility to deliver the machine in question to our service premises or to the premises of our appointed agent at the consumer's expense for replacement or repair as applicable.

Claim Procedure:

- Contact MAKINEX by phone or email informing us of your machine's problem or defect.

- Once the extent of the claim has been assessed, we retain the right to compensate the consumer for such defect, or repair (pars & labour), or replace the machine under warranty.
- All warranties will be carried out by MAKINEX authorised staff or appointed agents at a premises to be determined by the Manufacturer.
- Transportation charges on product submitted for repair or replacement under this warranty are the sole responsibility of the purchaser. This warranty only applies to the original purchaser and is not transferable.
- It is the responsibility (and cost) of MAKINEX or our appointed agent to return the machine to be repaired or replaced under warranty to the consumer- this is valid for domestic territories only (e.g. Australian units will be delivered within Australian territory, USA units will be delivered within USA territory and European units will be delivered within its designated country's territories).
- Where the specific warranty component (e.g. Actuator) is under a Manufacturer's warranty other than MAKINEX (e.g. LINAK), the consumer can either contact MAKINEX or the applicable Manufacturer for repairs where such warranty was registered with that manufacturer at purchase.
- Warranty calls will only be carried out by our representatives and not via client's choice of repairer. We will not accept back charges for any work not carried out by our representatives, or accept any charges due to equipment being un-operational for any reason even during its warranty period.

WARRANTY CONTACT INFORMATION:

AUSTRALIA

Tel + 61 2 9460 8071
Fax +61 2 9439 9815
d.lobban@Makinex.com.au
15 Waltham St, Artarmon, NSW
2064 AUSTRALIA

USA

Tel 855-625-4639

EUROPE

Tel +31 (0)6 24881203
+31 (0)6 50841849

SERVICE & PART ORDERING

For service and ordering parts, please call

AUS: 1300 795 953 or +61 2 9460 8071

USA: 855-625-4639

EUROPE: +31 (0)6 24881203 or +31 (0)6 50841849

Or your nearest MAKINEX distributor

We have very knowledgeable, experienced staff to assist you with help and advice.

10. SALES AND SPARE PARTS

For sales and spare parts for all Makinex products; please refer to your distributor below:



AUSTRALIA/ NEW ZEALAND
UNITED STATES OF AMERICA
EUROPE

W makinex.com
E sales@makinex.com

