

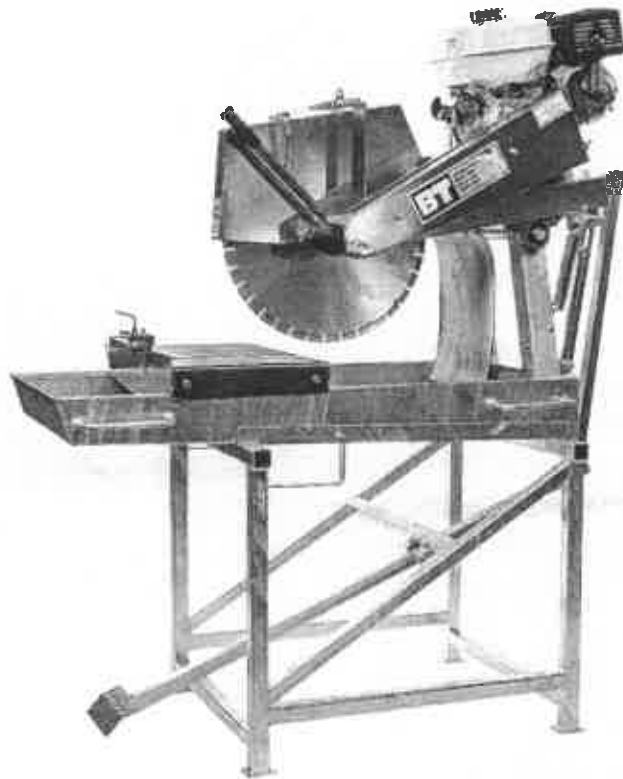









**BLSAWP
Honda Petrol Blocksaw
20" Blade**



DO NOT operate unless you have been instructed in its safe use and operation.

	Appropriate safety footwear with substantial uppers must be worn.		Hearing protection
	Respiratory masks		Close fitting/protective clothing with high visibility must be worn.
	Sunglasses / safety glasses		Tight fitting safety gloves
	No Smoking		Do not operate under the influence of alcohol or drugs
	Heavy equipment - 150kg		Danger - moving parts

Contents

1. Introduction	2
1.1. Welcome	2
1.2. General Safety	2
1.3. About the BT Block Saw	3
2. Lifting	5
3. Operation and Control	7
3.1. Set up	7
3.2. Start-up sequence	9
3.3. Cutting Techniques	11
4. Maintenance	13
4.1. Cleaning	13
4.2. Blade Change	14
4.3. Belt change and tension	16
4.4. Carriage wheel replacement	18
4.5. Check vertical blade alignment	19
4.6. Correcting vertical blade alignment	20
4.7. Check vertical blade alignment	21
4.8. Correcting vertical blade alignment	22
5. Spare Parts list	23
6. Conditions of Warranty	24

Introduction

Welcome

Congratulations for purchasing the BT Engineering Block Saw and welcome to the family. BT Engineering has spent the last 50 years working with brickies like yourself to develop a product that will work as hard and as long as you do. This is the why are the name brickies trust.

This operation manual contains important information relating to the safe operation and maintenance of you BT Block saw. Please take the time to carefully read this manual prior to using the equipment.

General Safety

The BT Block saw is designed to give you safe and reliable cutting if operated and maintained in accordance to this manual. Please ensure that the following general safety measures are taken prior to every cut.

1. The saw is positioned in a well-ventilated area. The engine emits toxic carbon monoxide gas.
2. The stand is positioned on a flat and even surface.
3. The base is securely fastened to the stand.
4. The work area is well lit and free from trip hazards.
5. The blade and belt guards are in place.
6. The water hose is securely attached and there is adequate water supply.
7. Only 20" diamond impregnated blades are used and inspected for cracks or flaws that may render the blade unsafe.
8. You are familiar with the operation of the on/off functionality.
9. The saw is never left running unattended.
10. Allow to cool prior to refueling.
11. The use of appropriate personal protective equipment (PPE).
12. Compliance with any other local and or site-specific procedures.



About the BT Block Saw

The BT Block saw is the largest saw we manufacture. It has been designed to cut through cement blocks from one direction, there is no need to turn the block over to complete the cut. This heavy-duty saw is built to last, serving those who know what is needed to get the job done right.

Item		Specification
Blade diameter		510mm (20")
Blade cutting depth		200mm (8")
Carriage table size		560 x 350 (22"x 13.5")
Motor fuel		Unleaded Petrol / Gasoline
Fuel tank Capacity		5.3 L (1.4 US qt, 1.17 Imp gal)
Motor oil - Ambient Temp	10 TO 40°C (50-105°F)	SAW 10W-30
	-15 TO 10°C (5-50°F)	SAE 5W
Engine oil Capacity		1.1 L (1.2 US qt, 1.0 Imp gal)
Assembled dim.		1450 x 700 x 1700 (57 x 28 x 67")
Packed / Transport dim.		1450 x 700 x 1070 (57 x 28 x 42")
Weight - Dry		150 kgs (330lbs)
Weight - Wet		160 kgs (355lbs)
Warranty – Motor (Honda)		3 years
Warranty – Saw (BT Engineering)		1 Year

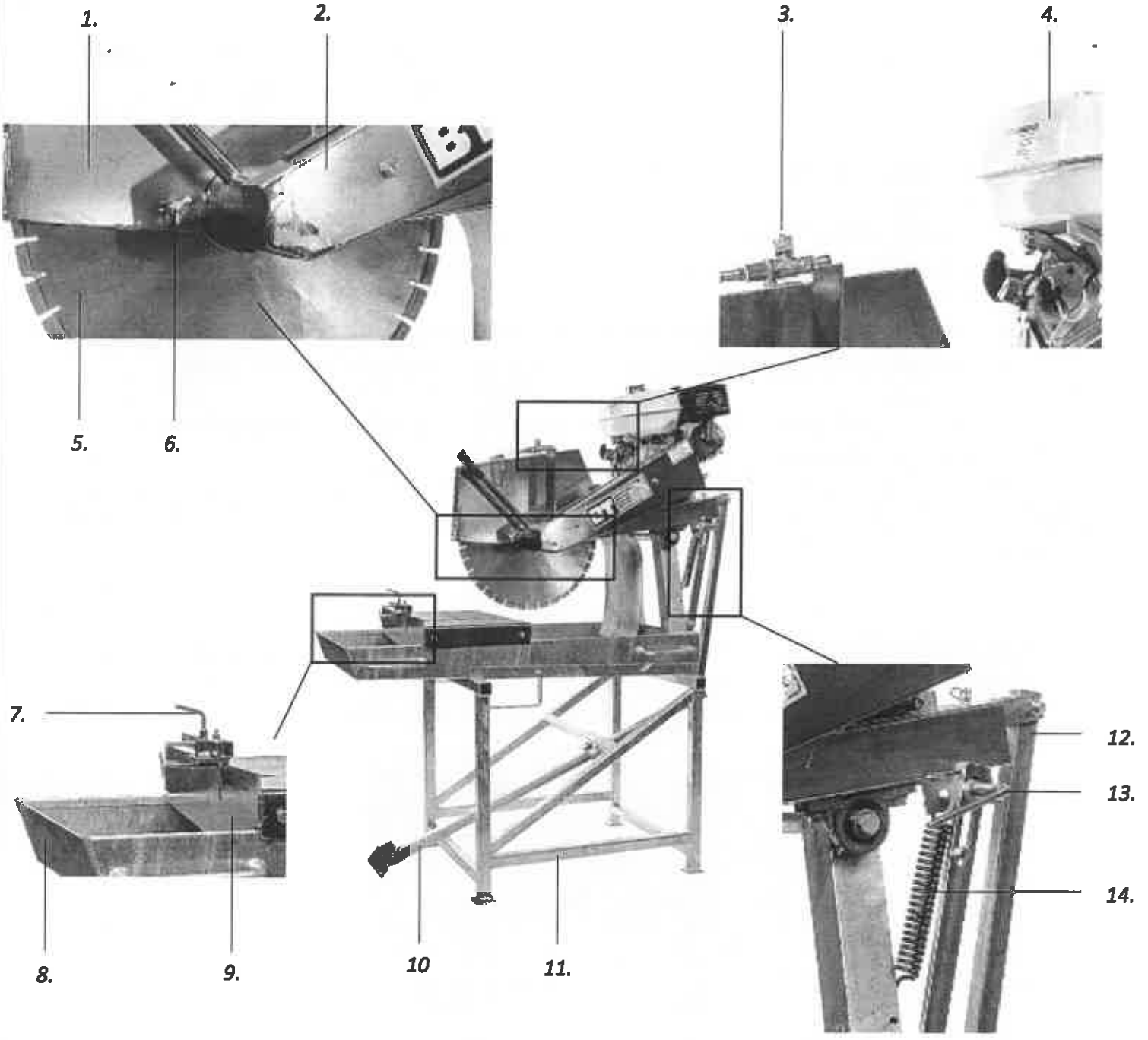

1.	Blade Guard
2.	Blet Guard
3.	Water tape and Hose connection
4.	Motor
5.	510mm (20") Diamond
6.	Blade Guard Wing nut
7.	Mitre Guide
8.	Base
9.	Carriage
10.	Pedal
11.	Stand
12.	Pedal Push Arm
13.	Lock down nut
14.	Spring – Block Saw

Lifting

The BT petrol block saw is a heavy-duty unit weighing 150kgs (330lbs). Prior to moving the saw either on site or loading or unloading from transport you must check the following:

1. The motor is cool. You must allow at least 15 minutes between the saws last use and any lifting operation. The hot exhaust system can cause burns and ignite flammable materials.
2. Both the ignition switch and fuel leave are in the off position.
3. The water supply is off and removed from water tap connection.
4. The base is clean and dry.
5. The blade is raised to its max height and locked in place using the lock down nut.
6. The pedal push arm is disconnected from the arm and the pedal is raised towards the base.
7. The carriage is removed from base. This can be moved and secured independently of the base and stand.

Lifting

Manual

Ideally the block saw is maneuvered mechanically due to its weight. It can however be moved by a minimum of a four (4) person lift. To make the lift easier the base can be removed from the stand. By removing the T-screws on each side of the stand.

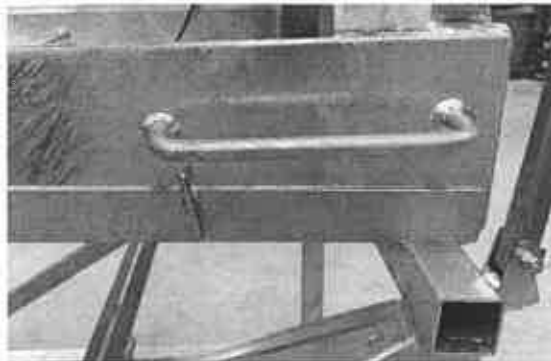

Be sure that you plan the lift that is who is leading, the path to be taken, and each stage of the lift be prior to commencing the lift.

Mechanical

When conducting a mechanical lift be sure that the base is securely fastened to the stand. As the lift will be done using the stand.

DO NOT attach lifting slings or chains to the four handles. These are not to be used for a mechanical lift.

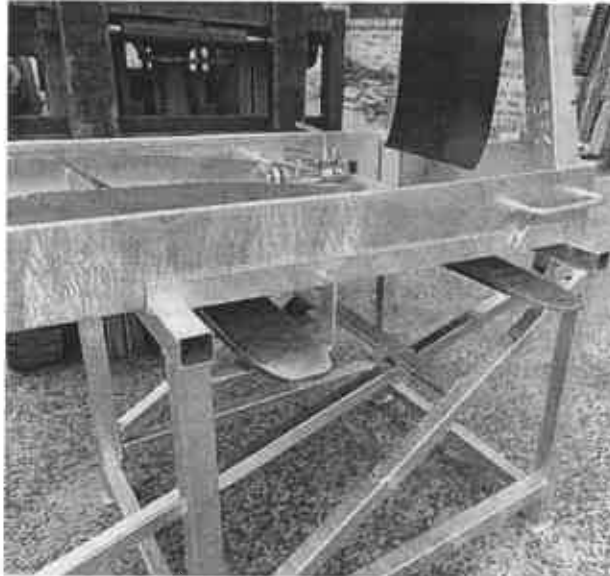

Operation and Control

Set up

Making sure the saw is set up correctly is crucial for the operator's safety, those around the saw and the saw itself. The following steps must be taken prior to any cutting.

1. The saw is on a flat and even surface.
2. The area is well ventilated and lit.
3. The base is securely fastened to the stand.
 - I. Insert T screw through the stand and base.
 - II. Screw into the locking plate on the inside of the base.
4. The pivot arm is connected to the motor mount.
 - I. Insert the pedal push arm into the motor mount
 - II. Insert pin through the motor mount

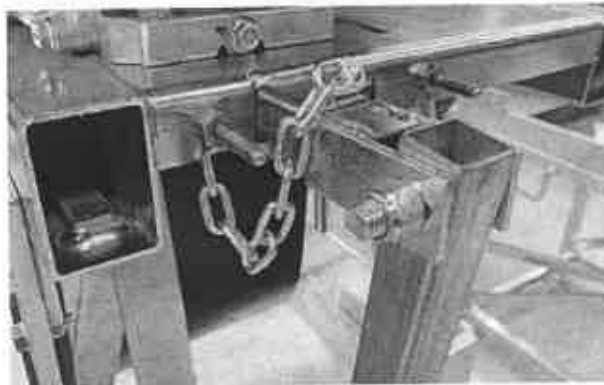
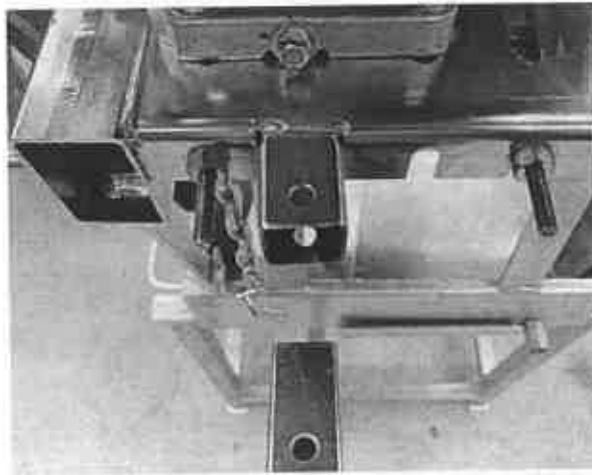

5. Check to around the engine for signs of oil or petrol (gasoline) leaks.
6. Remove any excessive dirt or debris, especially around the muffler and recoil starter.
7. Check the fuel and oil levels.
8. Check that the correct blade size and type is installed for that material to be cut.

Note: See the Blade Change steps in the maintenance section of this manual.

 - I. Maximum blade size is 510mm (20")
 - II. Hard material (Concrete pavers / Terracotta / Granite) - Use a soft matrix blade. The soft blade leaves the diamond chips exposed allowing them to cut through the material.
 - III. Soft material (Cement block / Besa block / Sandstone) - Use a hard blade. The hard blade supports the diamond chips allowing them to cut through the material.
9. Check all guards are fastened securely in place.

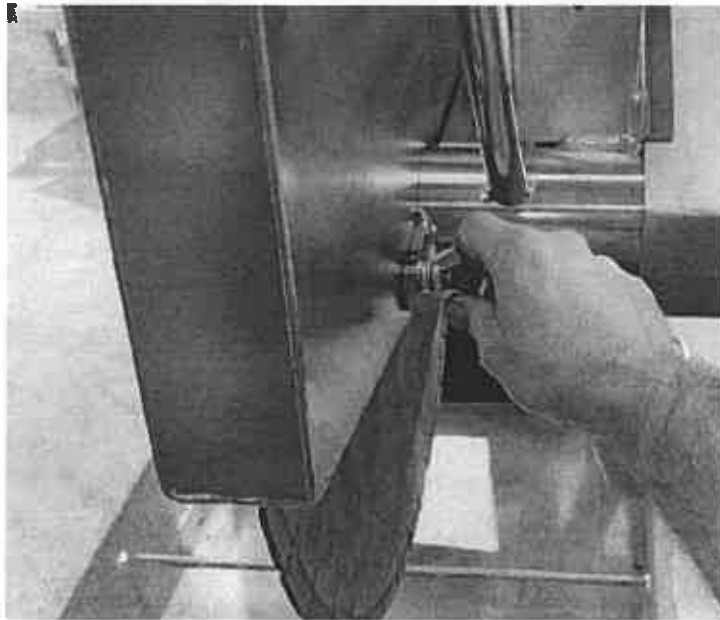

10. Always use a BT carriage; check that it is running along the tracks smoothly.

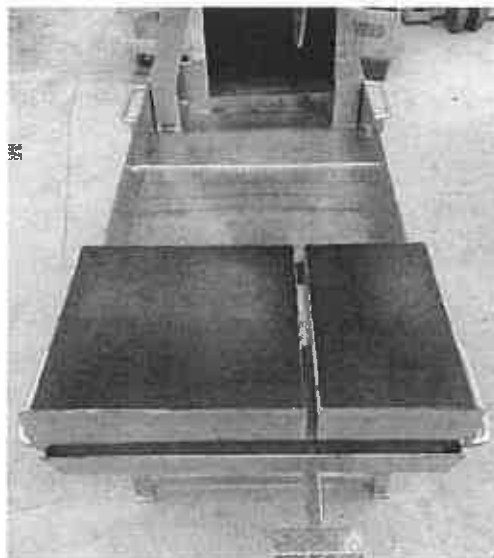

11. A hose is connected to the water tap.

Start-up sequence

1. Ensure material and carriage is away from the blade.
2. Move the fuel valve lever to the ON position.

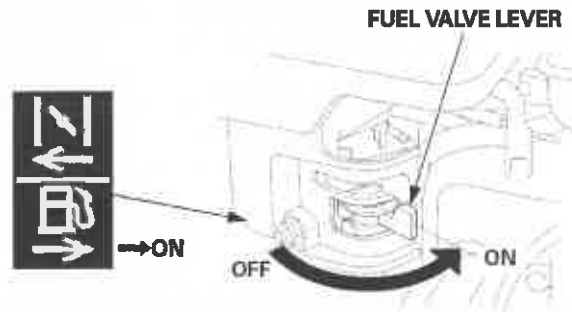

3. To start a cold engine, move the choke lever to the closed position. If the engine is warm, leave the choke in the OPEN position.

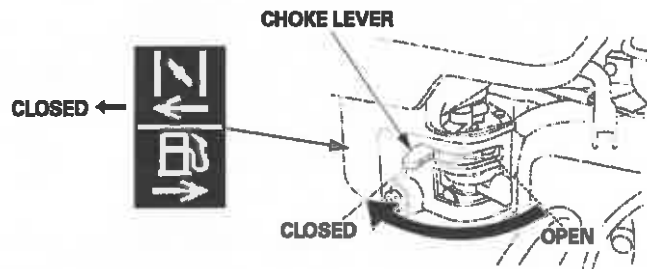

4. Move the throttle lever away from the Min. position about 1/3 of the way toward the Max. position.

Note: we have set the Max. position for the throttle to ensure the maximum revolutions of the blades are not exceeded.

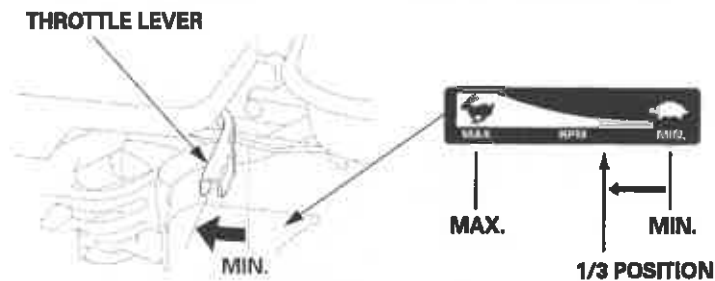

5. Turn the engine switch to the ON position.

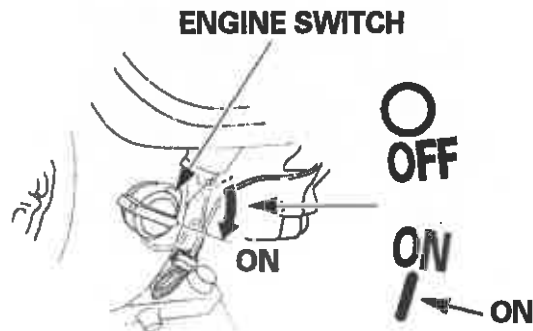

6. Pull the start grip lightly until you feel resistance, then pull briskly in the direction of the arrow.

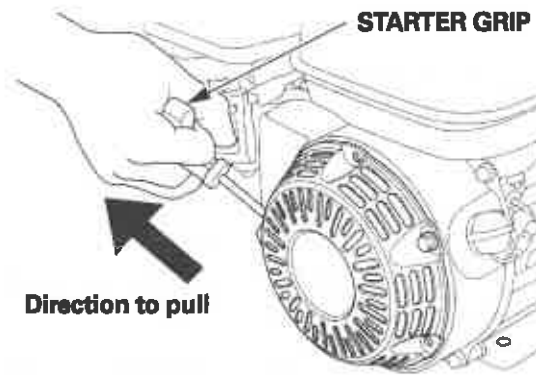

7. If the choke level was moved to the CLOSED position to start the engine, gradually move it to the OPEN position as the engine warms up.
8. Turn water ball valve to the on position.

Cutting and Techniques

When cutting Remember to keep hands and fingers at least 50mm (2") away from the blade.

DO NOT:

1. Hold a brick or block you are cutting with your hand across the front of the blade.
2. Ever put your fingers inside the holes or slots of extruded brick or block.
3. Ever put your finger in front or behind the blade whilst it is running.
4. Ever cut more than one brick or block at once.
5. When making deep cuts. Eg. 110mm (4") splits. Always apply downward pressure on the material being cut and do not push cut sections against the blade.
6. Ever force the blade through the material being cut.
7. Attempt to hold or grab a brick or block if it does jam on a blade.
 - a. Let go of the brick/ block immediately.
 - b. Turn off the saw immediately.
8. Cut material with cracks.

There are two cutting methods that are typically used when operating a block saw these are the back cut and step cut.

Back cutting

The safest was to cut because blade is lock into position. Removing the likelihood of the block being caught by the blade. Causing the block to be thrown backwards through the splash guard or being lifted and jammed into the arm and blade cover. The downside to this method it is a little slower and causes more wear to the blade because more of the blade is exposed to more friction for longer.

1. Set the block in position on the carriage.
2. Ensure the carriage is at the front of the base. *Closest to the operator.*
3. Loosen the lock down nut.
4. Set blade in the lowered position. making sure it is low enough to cut through the entire block.
Note: Just lower than the bearing surface of the carriage.
5. Lock the blade in place using the lockdown nut.
6. Turn the water on.
7. Turn the saw on.
8. Then slowly and steadily push the block through the blade.

Step cutting

Usually a quicker method however there is more inherent risk as both the blade and block are moving. The operator must ensure the cut being performed the back surface of the block to the front, so the likelihood of the block being caught by the blade is reduced.

1. Set the block in position on the carriage.
2. Ensure the carriage is at the front of the base. *Closest to the operator.*
3. Turn the water on.
4. Turn the saw on.
5. Loosen the lock down nut.
6. Leaving the blade in its raised position push the block towards the blade.
7. Once the back 2 inches or so of the block is under blade.
8. Lower the blade to start the cut.
9. As the blade starts to break through the block raise the blade.

10. As the blade is being raised push the block further into the blade.
11. Lower the blade to continue the cut.
12. Repeat steps 7 to 9. Stepping through the block until the cut is complete. It is important to
 - keep even pressure on the blade as both the block is pushed in, and the blade is lowered.

Maintenance

It is critical for the health and safety of the operator and those around them the saw is correctly maintained.

Before conducting any maintenance, make sure the engine is off and cool with both the engine switch and fuel valve lever in the off and closed position. To prevent accidental startup, disconnect the spark plug cap.

It is important that the saw is clean and dry to prevent any injury whilst handling that saw and its components. Below is the recommended minimum maintenance schedule.

Item	Frequency - Every	Use	After First Month OR 20 Hrs	3 Months OR 50 Hrs	6 Months OR 100 Hrs	Year OR 300 Hrs	Ref.
Engine Oil	Check	•					<i>See Honda manual supplied for more details</i>
	Change		•		•		
Air Cleaner	Check	•					
	Clean		•		•		
	Replace					•	
Spark Plug	Check / Adjust				•		
	Replace					•	
Fuel tank & Filter	Clean				•		
Fuel Tube	Clean						
Carriage wheels	Clean	•					
	Replace					•	
Clean Saw		•					
Belts	Check	•	•		•		
	Replace					•	
Blade Alignment	Check			•			
Arm Bearings	Check			•			
	Grease					•	

Cleaning

- Brush down the motor with a stiff bristle brush (for example a clean masonry brush) removing any built-up dust and dirt.
Note: Be gentle when brushing over and near the engine switch, oil plug and fuel lever.
- Make sure the drain hole in the back left hand corner of the base is clear, this will allow the water to drain out.
- Loosen wing nut on the right-hand side of the blade cover.
- Lift the blade cover to expose the blade.
- Lift the blade cover exposing the blade and inside of the cover. – *See the blade change instructions.*
- Flush both the blade and inside of the cover with water (DO NOT use a high-pressure hose), using a stiff bristle brush (for example a clean masonry brush) remove any dirt.
Note: DO NOT spray the motor with the hose as water can get into the air filter and or muffler and cause damage to the engine.
- Once dry lower and lock the blade cover in place.
- Wash down your carriage. Be sure to turn it upside down and make sure the wheels are free from any dirt build up.

Blade Change

1. Using the lock down nut lock arm in the lifted position.



2. Loosen wing nut on the right-hand side of the blade cover.

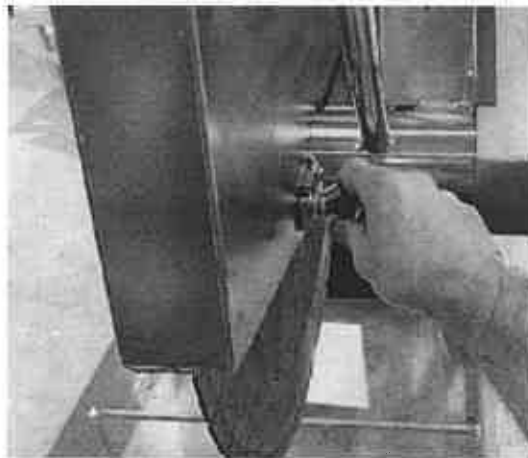

3. Lift the blade cover to expose the blade.



- Undo and remove the blade nut.



Note: This is a left-hand threaded nut. Turn in a clockwise direction to loosen.

- Remove the outer blade collar. Do not remove the inner blade collar.



- Remove the old blade.
- Install new blade. Check the direction of rotation of the blade.
- Slide on outer blade collar.
- Fasten blade nut.
Note this is a left-hand nut. Turn in an anti-clockwise direction
- Check that the blade is square and center to the carriage.
- Lower the blade cover.
- Fix in place by tightening the wing nut on the right-hand side of the blade cover.

Belt Replacement and Tensioning

1. Unscrew the nuts on the outside of the belt guard.

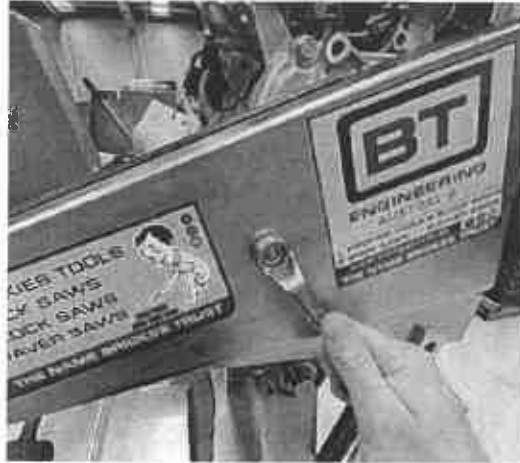

2. Remove the belt guard. This will expose the two V-belts and pulleys.

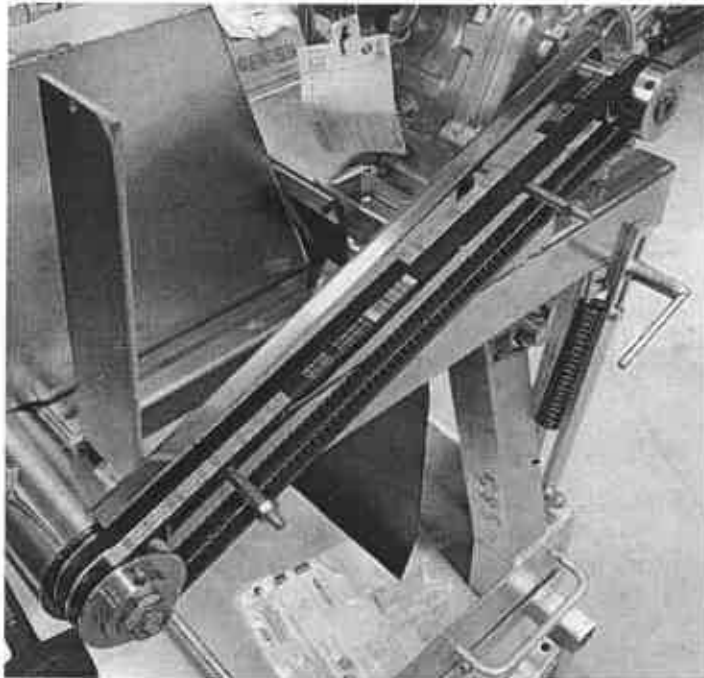

3. Loosen the four (4) motor mount bolts. Two at the front and two at the back.

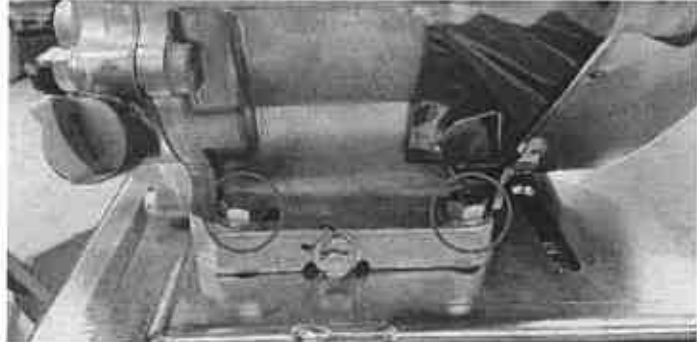

4. Loosen the two (2) motor tension nuts. The motor will slide forward reducing the belt tension allowing you to remove the belts.

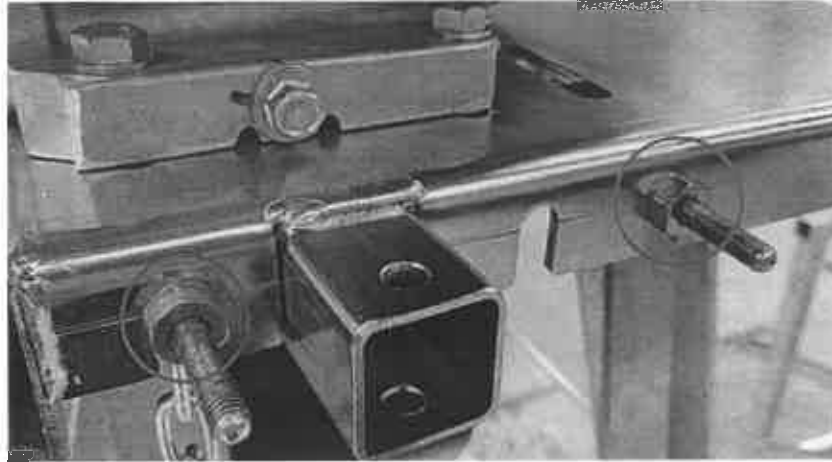

5. Remove the old belts.
6. Brush off any built up of dirt using a stiff bristle brush (a clean masonry brush)
7. Fit new belts - XPA1250
8. Tension belts by doing up the two motor tension nuts.
9. Continue to tighten until you can squeeze the middle of the belts inwards. The deflection should be no greater than 15mm (5/8")

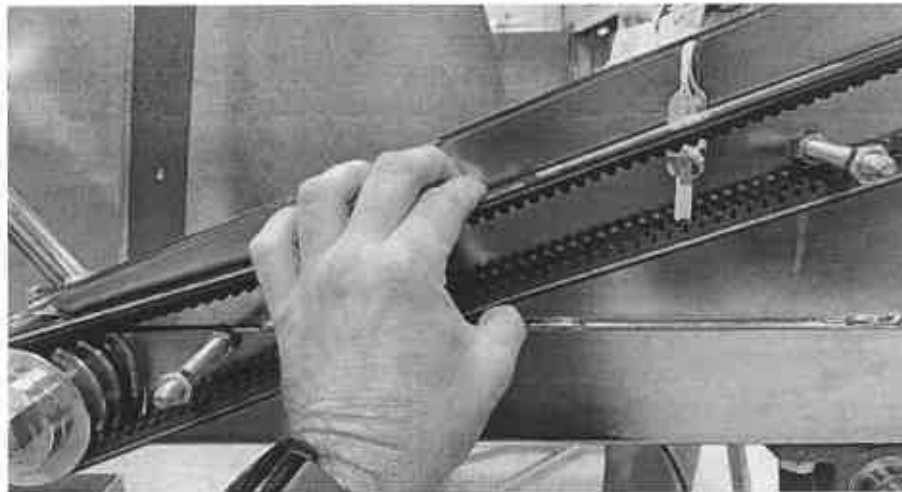

Note: Excessive tension will shorten the life of the belts and pulleys.

10. Once correct tension check belts are parallel.
11. Place a straight edge on the motor pulley and running it towards the blade pulley. You are looking for the pulleys to be parallel.



12. Adjust the tensioning nuts individually to make sure the belts are aligned.

Note: Check belt tension as you work to align the pulleys as you may need to loosen the nuts rather than tighten them.

13. Tighten the four motor mount bolts.

14. Fit the belt guards.

Carriage Wheel Replacement

1. Turn carriage over to expose the wheels.

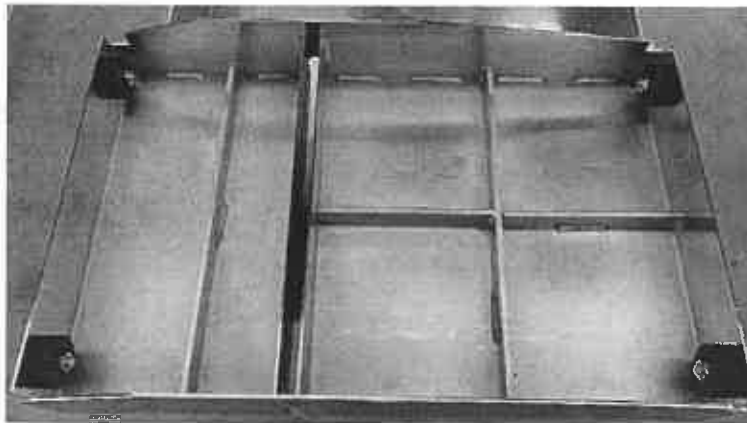

2. Using a spanner and socket undo each bolt.

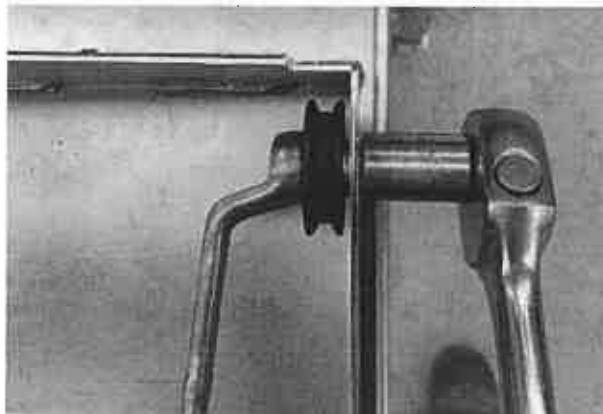

Note: Record the number and position of the packing washers between the carriage body and the wheel.

3. Replace old bolt with new. The head of the bolt is to be on the outside.

4. Replace the old packing washers between the inside face of the carriage and the new wheel.

Note: extra packing washers can be added to improve stability and blade alignment

5. Install the new wheels.

6. Screw on new nut and tighten with a spanner and socket.

7. Test stability and blade alignment. If not correct repeat steps 2-7.
8. Once carriage is stable and rolling smoothly, the carriage is ok to return to service.

Check Vertical Blade Alignment

1. Remove the carriage from the base.
2. Using the lock down nut lock arm in the raised position.
3. Loosen wing nut on the right-hand side of the blade cover.
4. Lift the blade cover to expose the blade.
5. Place a straight edge across the top edges of the base.



6. On the left-hand side of the blade place a one edge of the square on the straight edge and the other edge of the square on the blade.



7. When the blade is vertical there will be no variation between blade and the square.

Correcting Vertical Blade Alignment

1. Remove the pivot bearing nuts:
 - I. If the bottom of the blade is proud remove the right-hand side nuts.
 - II. If the top of the blade is proud remove the left-hand side nuts.

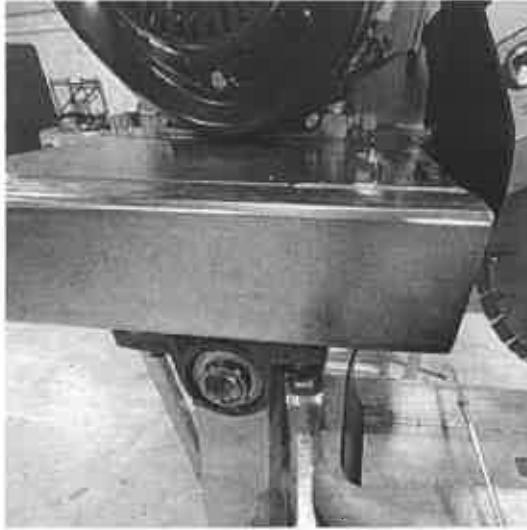

2. Place a washer between the motor mount and the pivot bearing.



Washers

Note: These are 1/2" x 1 1/2" Flat Washers.

3. Tighten pivot bearing nuts.
4. Check vertical alignment.
5. If still out repeat steps 1-4.
6. If corrected check horizontal alignment.

Check Horizontal Blade alignment

1. Remove the carriage from the base.
2. Using the lock down nut lock arm in the lowered position.
3. Loosen wing nut on the right-hand side of the blade cover.
4. Lift the blade cover to expose the blade.
5. Clamp a straight edge to the right-hand side of the blade. Ensure the straight edge runs the entire length of the base.

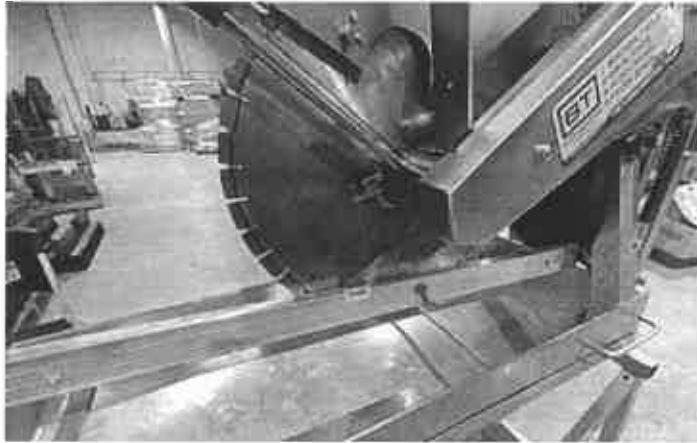

6. On the right-hand side measure the distance between the straight edge and the outer edge of the base.
7. The measurement should be the same at the front (Closest to the operator) and the back (Closest to drain) the measurement should be within $\pm 1.00\text{mm}$ ($1/32''$).

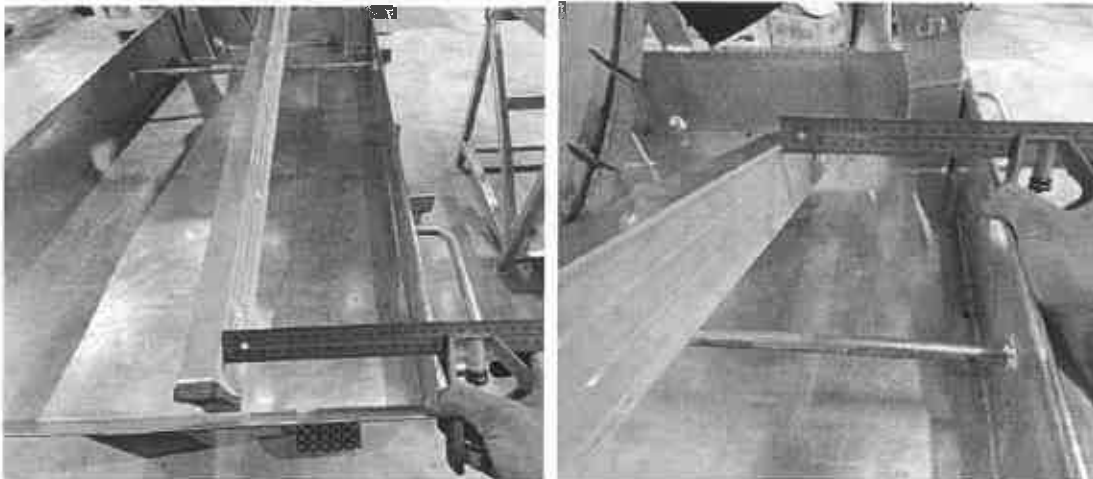

8. The blade is straight when the measurement is within the tolerance.

Correcting Horizontal Blade Alignment

1. Loosen wing nut on the right-hand side of the blade cover.
2. Lift the blade cover to expose the blade.
3. Remove the belt guard.
4. Loosen all pivot bearing bolts.
5. Using soft hammer gently tap the blade shaft until the measurement between the straight edge and the outer edge of the base is the same at the front and the back.



6. Gently tighten pivot bearing nuts in a star pattern to reduce the chance of moving the blade back out of alignment.

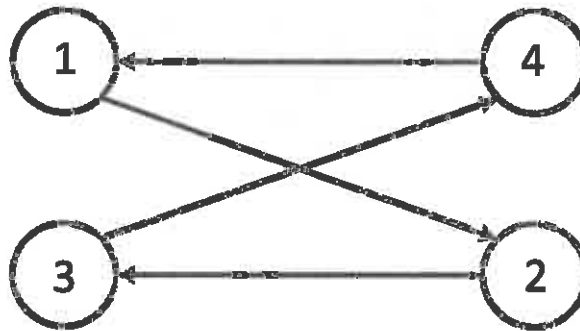

7. Check horizontal alignment:
 - I. If blade has moved repeat steps 2-4.
 - II. If blade has remained in place.
8. Replace the belt guard.

Spare Parts

The use of genuine BT spares is recommended to ensure the integrity of the parts and the life of the saw.

Part Description	Part number	Standard Qty per saw
Miter Guide	BSAWMI	1
Block Saw Motor	BLMOTGX270	1
Block saw Carriage – Petrol	BLSAWC-P	1
Carriage Wheel – Petrol (inc. nut and bolt)	BSAWW-P	4
Blade Shaft Assembly – Petrol Block Saw	BLSAWBSK-P	1
V-Belt – Petrol Block Saw	BLETXPA1250	2
Water Ball valve kit – Block Saw	BLSAWBV	1
Tilt Guide	BSAWAG	0

CONDITIONS OF WARRANTY

This BT Blocksaw is warranted free from defective workmanship and or materials for a period of Twelve (12) Months from the date of sale to the original purchaser.

Our goods come with guarantees that cannot be excluded under the Australian Consumer Law. You are entitled to a replacement or refund for a major failure and for compensation for any other reasonably foreseeable loss or damage. You are also entitled to have goods repaired or replaced if the goods fail to be of acceptable quality and the failure does not amount to a major failure.

Our Liability hereunder is strictly limited to supplying replacements parts as abovementioned. BT shall not in any event extend to any consequential loss or damage whatsoever, or to any defect due to accident, misuse or any cause beyond our control.

To make a warranty query or claim, please contact your retailer and provide your serial number to confirm proof of purchase.

The Consumer will pay for freight costs and delivery charges to and from capital cities, if Blocksaw is to be returned to BT Engineering or Retailer for repair or replacement.

Warranty will not be covered in the event of damages or failures by the consumer for incorrect use.

These conditions of warranty exclusively compromise the warranty expressly given by us under the undermentioned BT Blocksaw.

Serial No: 647 Date of Purchase: 1 / 1 / 2011

Purchased from: _____

WARRANTY
HONDA Motor
Powerequipment.honda.com/registration

WARRANTY
BT BLOCKSAW
BT ENGINEERING
+61 2 9521 3041
www.btengpl.com.au
sales@btengpl.com

Please retain this half of the warranty. To be presented when any claim is made under Warranty

Please complete this coupon and return to:

B.T Engineering Group Pty Ltd, 5 Marshall Road, Kirrawee NSW 2232 or email to sales@btengpl.com

Model : BLSAWP	Type: Honda Petrol
Serial Number :	Date of Purchase:
Name :	
Address:	
Contact Phone :	Email:
Purchased From:	Ph :

