

Operator's Manual

Floor Saw

BFS 16

BFS 18

BFS 20



5000405152 01 0412



Copyright notice

© Copyright 2012 by Wacker Neuson Corporation.

All rights, including copying and distribution rights, are reserved.

This publication may be photocopied by the original purchaser of the machine. Any other type of reproduction is prohibited without express written permission from Wacker Neuson Corporation.

Any type of reproduction or distribution not authorized by Wacker Neuson Corporation represents an infringement of valid copyrights. Violators will be prosecuted.

Trademarks

All trademarks referenced in this manual are the property of their respective owners.

Manufacturer

Wacker Neuson Manila Incorporated

Lot 2,Blk 1 Phase 3 , PEZA Drive, First Cavite Industrial Estate, Brgy. Langkaan
Dasmariñas, Cavite, Philippines 4126

Tel: +63-(0)2-580-7136 Fax: +63-(0)2-580-7122

www.wackerneuson.com

Translated instructions

This Operator's Manual presents a translation of the original instructions. The original language of this Operator's Manual is American English.

Foreword	3
1. Safety Information	4
1.1 Laws Pertaining to Spark Arresters	4
1.2 Operating Safety	5
1.3 Operator Safety while using Internal Combustion Engines	6
1.4 Service Safety	7
1.5 Label Locations	8
1.6 Warning and Informational Labels	9
2. Technical Data	12
2.1 Engine Data	12
2.2 Machine Data	13
2.3 Dimensions	13
3. Operation	14
3.1 Recommended Fuel	14
3.2 Application	14
3.3 Before Starting	15
3.4 To Start	16
3.5 To Stop	16
3.6 Guide Handle Adjustment	17
3.7 Use of Cutting Blade	18
3.8 Guide Wheel	20
3.9 Cutting Depth Adjustment	21

4. Maintenance 22

- 4.1 Periodic Maintenance Schedule22
- 4.2 Spark Plug23
- 4.3 Air Cleaner24
- 4.4 Engine Oil25
- 4.5 Cleaning Fuel Strainer26
- 4.6 Drive Belt27
- 4.7 Rear Wheel Maintenance28
- 4.8 Lifting the machine29
- 4.9 Transporting Machine30
- 4.10 Storage30

CALIFORNIA

Proposition 65 Warning:



Engine exhaust, some of its constituents, and certain vehicle components, contain or emit chemicals known to the State of California to cause cancer and birth defects or other reproductive harm.

Foreword

This manual provides information and procedures to safely operate and maintain this Wacker Neuson model. For your own safety and protection from injury, carefully read, understand and observe the safety instructions described in this manual.

Keep this manual or a copy of it with the machine. If you lose this manual or need an additional copy, please contact Wacker Neuson Corporation. This machine is built with user safety in mind; however, it can present hazards if improperly operated and serviced. Follow operating instructions carefully! If you have questions about operating or servicing this equipment, please contact Wacker Neuson Corporation.

The information contained in this manual was based on machines in production at the time of publication. Wacker Neuson Corporation reserves the right to change any portion of this information without notice.

All rights, especially copying and distribution rights, are reserved.

Copyright 2012 by Wacker Neuson Corporation.

No part of this publication may be reproduced in any form or by any means, electronic or mechanical, including photocopying, without express written permission from Wacker Neuson Corporation.

Any type of reproduction or distribution not authorized by Wacker Neuson Corporation represents an infringement of valid copyrights and will be prosecuted. We expressly reserve the right to make technical modifications, even without due notice, which aim at improving our machines or their safety standards.

1. Safety Information

This manual contains DANGER, WARNING, CAUTION, *NOTICE*, and NOTE signal words which must be followed to reduce the possibility of personal injury, damage to the equipment, or improper service.



This is the safety alert symbol. It is used to alert you to potential personal injury hazards. Obey all safety messages that follow this symbol to avoid possible injury or death.



DANGER

DANGER indicates a hazardous situation which, if not avoided, will result in death or serious injury.



WARNING

WARNING indicates a hazardous situation which, if not avoided, could result in death or serious injury.



CAUTION

CAUTION indicates a hazardous situation which, if not avoided, could result in minor or moderate injury.

NOTICE: Used without the safety alert symbol, **NOTICE** indicates a situation which, if not avoided, could result in property damage.

Note: *Contains additional information important to a procedure.*

1.1 Laws Pertaining to Spark Arresters

Notice: State Health Safety Codes and Public Resources Codes specify that in certain locations spark arresters be used on internal combustion engines that use hydrocarbon fuels. A spark arrester is a device designed to prevent accidental discharge of sparks or flames from the engine exhaust. Spark arresters are qualified and rated by the United States Forest Service for this purpose.

In order to comply with local laws regarding spark arresters, consult the engine distributor or the local Health and Safety Administrator.

1.2 Operating Safety



Familiarity and proper training are required for the safe operation of the machine. Machines operated improperly or by untrained personnel can be hazardous. Read the operating instructions contained in this manual and the engine manual, and familiarize yourself with the location and proper use of all controls. Inexperienced operators should receive instruction from someone familiar with the machine before being allowed to operate it.

- 1.2.1 Do not allow anyone to operate this equipment without proper training. People operating this equipment must be familiar with the risks and hazards associated with it.
- 1.2.2 Do not touch the engine or muffler while the engine is on or immediately after it has been turned off. These areas get hot and may cause burns.
- 1.2.3 Do not use accessories or attachments that are not recommended by Wacker Neuson. Damage to equipment and injury to the user may result.
- 1.2.4 NEVER operate the machine with the beltguard missing. Exposed drive belt and pulleys create potentially dangerous hazards that can cause serious injuries.
- 1.2.5 Do not leave the machine running unattended.
- 1.2.6 Be sure operator is familiar with proper safety precautions and operation techniques before using machine.
- 1.2.7 Always wear protective clothing appropriate to the job site when operating the machine.
- 1.2.8 Wear hearing protection when operating equipment.
- 1.2.9 Close fuel valve on engines equipped with one when machine is not being operated.
- 1.2.10 Store the machine properly when it is not being used. The machine should be stored in a clean, dry location out of the reach of children.
- 1.2.11 Always operate machine with all safety devices and guards in place and in working order. Do not modify or defeat safety devices. Do not operate machine if any safety devices or guards are missing or inoperative.
- 1.2.12 Read, understand, and follow procedures in the Operator's Manual before attempting to operate the machine.

1.3 Operator Safety while using Internal Combustion Engines



WARNING

Internal combustion engines present special hazards during operation and fueling. Read and follow the warning instructions in the engine owner's manual and the safety guidelines below. Failure to follow the warnings and safety standards could result in severe injury or death.

- 1.3.1 DO NOT run the machine indoors or in an enclosed area such as a deep trench unless adequate ventilation, through such items as exhaust fans or hoses, is provided. Exhaust gas from the engine contains poisonous carbon monoxide gas; exposure to carbon monoxide can cause loss of consciousness and may lead to death.
- 1.3.2 Do not smoke while operating the machine.
- 1.3.3 Do not smoke when refueling the engine.
- 1.3.4 Do not refuel a hot or running engine.
- 1.3.5 Do not refuel the engine near an open flame.
- 1.3.6 Do not spill fuel when refueling the engine.
- 1.3.7 Do not run the engine near open flames.
- 1.3.8 Refill the fuel tank in a well-ventilated area.
- 1.3.9 Replace the fuel tank cap after refueling.
- 1.3.10 ALWAYS check the fuel lines and the fuel tank for leaks and cracks before starting the engine. Do not run the machine if fuel leaks are present or the fuel lines are loose.

1.4 Service Safety

**WARNING**

A poorly maintained machine can become a safety hazard! In order for the machine to operate safely and properly over a long period of time, periodic maintenance and occasional repairs are necessary.





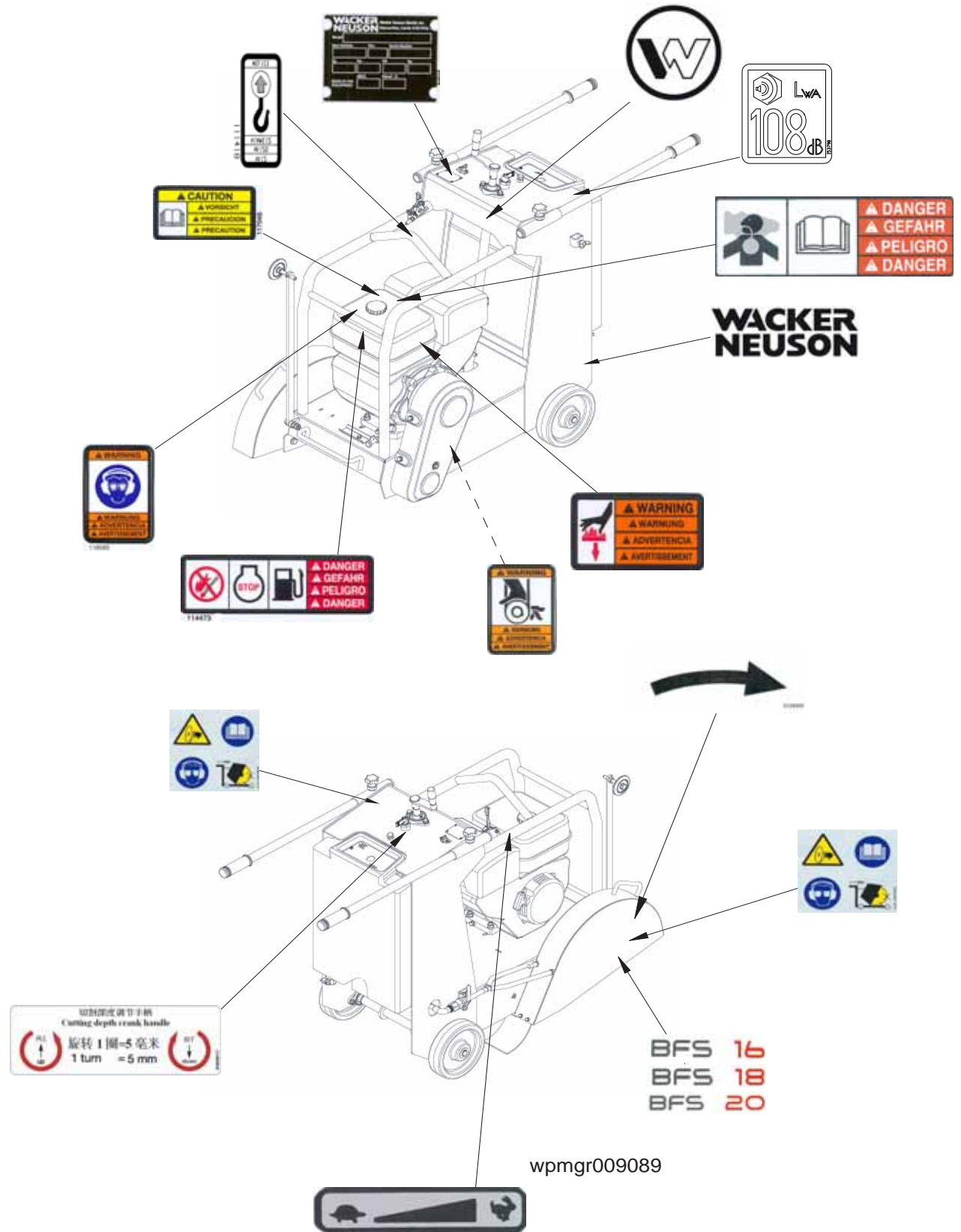

- 1.4.1 Do not attempt to clean or service the machine while it is running. Rotating parts can cause severe injury.
- 1.4.2 Do not crank a flooded engine with the spark plug removed on gasoline-powered engines. Fuel trapped in the cylinder will squirt out the spark plug opening.
- 1.4.3 Do not test for spark on gasoline-powered engines if the engine is flooded or the smell of gasoline is present. A stray spark could ignite the fumes.
- 1.4.4 Do not use gasoline or other types of fuels or flammable solvents to clean parts, especially in enclosed areas. Fumes from fuels and solvents can become explosive.
- 1.4.5 Keep the area around the muffler free of debris such as leaves, paper, cartons, etc. A hot muffler could ignite the debris and start a fire.
- 1.4.6 Replace worn or damaged components with spare parts designed and approved by Wacker Neuson.
- 1.4.7 Disconnect the spark plug on machines equipped with gasoline engines, before servicing, to avoid accidental start-up.
- 1.4.8 Keep the machine clean and labels legible. Replace all missing and hard-to-read labels. Labels provide important operating instructions and warn of dangers and hazards.







1.5 Label Locations



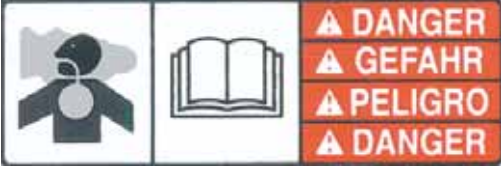

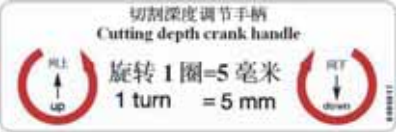
1.6 Warning and Informational Labels

Wacker Neuson machines use international pictorial labels where needed. These labels are described below.

Label	Meaning
 <p>A rectangular label with a black border. On the left, a pictogram shows a hand being burned by a red flame. On the right, the word 'WARNING' is written in four different languages: English, German, Spanish, and French.</p>	<p>WARNING! Hot surface</p>
 <p>A square label with a speaker icon and the text 'LWA 108 dB(A)'. The '108' is significantly larger than the other text.</p>	<p>Guaranteed sound power level in dB(A).</p>
 <p>A rectangular label with a black border. It features a pictogram of a hand caught in a rotating wheel. The word 'WARNING' is written in four languages.</p>	<p>WARNING! Hand injury if caught in moving belt. Always replace beltguard.</p>
 <p>A rectangular label with a yellow background and a black border. It shows a pictogram of an open book. The word 'CAUTION' is written in four languages. A small number '117045' is visible on the right side.</p>	<p>CAUTION! Read and understand the supplied Operator's Manual before operating this machine. Failure to do so increases the risk of injury to yourself and others.</p>
 <p>A vertical rectangular label with a black border. It features a pictogram of a lifting hook. The word 'NOTICE' is written at the top.</p>	<p>NOTICE Lifting point.</p>
 <p>A horizontal rectangular label with a black border. It shows a pictogram of a throttle lever with a turtle icon on the left and a rabbit icon on the right.</p>	<p>Throttle control lever: Turtle = Idle or Slow Rabbit = Full or Fast</p>
 <p>A rectangular label with a black border. It features a pictogram of a person wearing safety glasses and earplugs. The word 'WARNING' is written in four languages. A small number '118085' is visible at the bottom.</p>	<p>Warning! Always wear hearing and eye protection when operating this machine.</p>

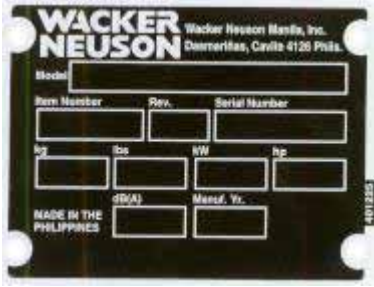
Label	Meaning
 <p>114473</p>	<p>DANGER! No sparks, flames, or burning objects near the machine. Shut off the engine before refueling.</p>
	<p>DANGER! Engines emit carbon monoxide; operate only in well-ventilated area. Read the operator's Manual.</p>
 <p>0129302</p>	<p>Cutting blade: rotation label</p>
	<p>Cutting depth label</p>
	<p>Machine operation instruction label</p>
	<p>Company label</p>
	<p>Machine name sticker</p>

Label	Meaning
 <p>The image shows a black nameplate with white text and fields. At the top, it reads 'WACKER NEUSON' in large letters, followed by 'Wacker Neuson Manila, Inc. Dasmariñas, Cavite 4126 Phils.'. Below this are several fields: 'Model' with a large empty box, 'Item Number', 'Rev.', and 'Serial Number' each with a smaller empty box. Further down are 'hp', 'kW', and 'hp' fields. At the bottom, it says 'MADE IN THE PHILIPPINES' and 'SERIAL' with a field, and 'Manuf. Yr.' with a field. There is a small vertical text 'BUSINESS' on the right side of the plate.</p>	<p>A nameplate listing the model number, item number, revision number, and serial number is attached to each unit. Please record the information found on this nameplate so it will be available should the nameplate become lost or damaged. When ordering parts or requesting service information, you will always be asked to specify the model number, item number, revision number, and serial number of the unit.</p>
 <p>The image shows a small rectangular label with a double-line border. It contains the text 'U.S. PAT. Nos.:' on the first line and 'OTHER U.S. AND FOREIGN PATENTS PENDING' on the second line.</p>	<p>This machine may be covered by one or more patents.</p>

2. Technical Data

2.1 Engine Data

Engine Power Rating

Net power rating per SAE J1995. Actual power output may vary due to conditions of specific use.

		BFS 16 0630098	BFS 18 0630099	BFS 20 0630129
Engine				
Engine Make		Wacker Neuson		
Engine Model		WM270	WM400	
Maximum rated power @ rated speed	kW (Hp)	6.6 (9.0)	10.3 (14)	
Operating speed	rpm	3600		
Spark Plug		NGK BR-6HS		
Air Cleaner	type	Dual element type (Urethane foam and paper element)		
Engine Lubrication	oil grade	Automotive Detergent Oil (API/SE or higher grade, SAE/ 10W-30 etc.)		
Engine Oil Capacity	ml (oz.)	1000(33.7)	1200 (40)	
Fuel	type	Regular unleaded gasoline		
Fuel Tank Capacity	l (qts.)	6.1(6.45)	7 (7.4)	

2.2 Machine Data

		BFS 16 0630098	BFS 18 0630099	BFS 20 0630129
Machine				
Weight	kg (lbs.)	132(291)	145(319)	147 (323.4)
Water Tank Capacity	l (qts.)	45 (47.6)		
Nominal Blade Speed	rev/min	2676		
Arbor Diameter	mm (in)	27 (1.06)		

2.3 Dimensions

mm (in.)

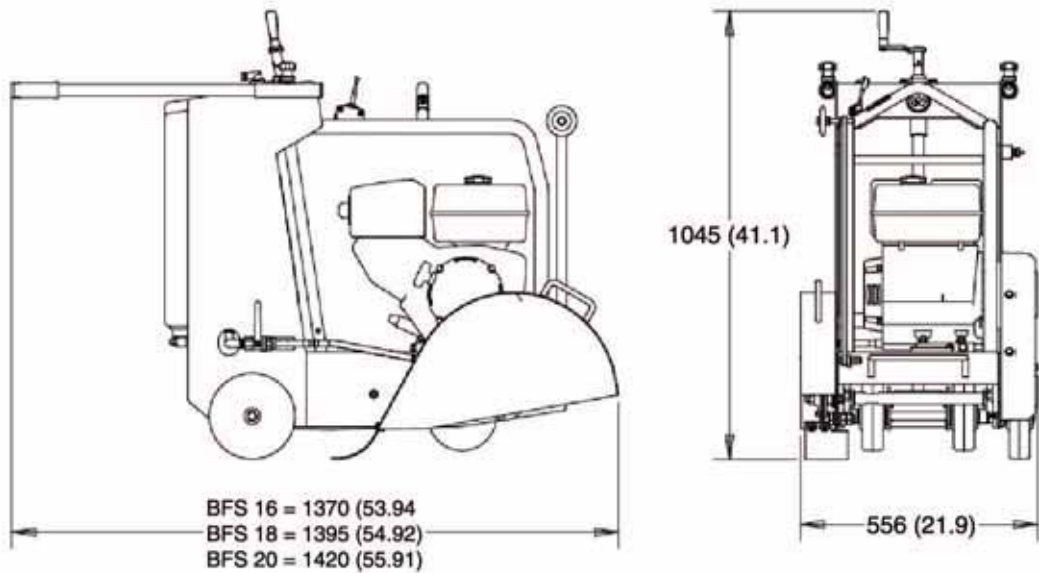

wpmgr009076

3. Operation

3.1 Recommended Fuel

The engine requires regular grade unleaded gasoline. Use only fresh, clean gasoline. Gasoline containing water or dirt will damage fuel system. Consult engine owner's manual for complete fuel specifications.

3.2 Application

The Floorsaw should only be operated in a forward direction. The drive engine fastened to the frame drives the cutting blade by way of a drive belt.

The infinitely variable cutting depth of the cutting blade is adjusted with the help of a hand crank, and 1 turn of the crank equals 5 mm (0.20 in) cutting depth adjustment.

The Blade guard can be swung away upwards for an easier assembly of the cutting blade.

The blade guard is moreover linked to the water tank via a hose and a coupling.

Wetting the cutting blade with water will stop dust forming during the cutting process.

The coupling fitted to the water hose means an external water supply can be used.

The engine works according to the 4-stroke principle, is started by means of a recoil starter, takes in the air via a dry air filter and is air cooled.

The engine speed can be infinitely varied with the help of the throttle lever; the optimum cutting speed of the cutting blade is only achieved when the drive engine is turning at full speed.

In order to facilitate the starting, the engine is provided with a choke.

During operation, there should always be sufficient water in the water tank

3.3 Before Starting

3.3.1 Read and understand the safety and operating instructions at the beginning of this manual.

3.3.2 Check:

- Oil level in the engine
- Fuel level
- Condition of the air cleaner
- Tightness of the external fasteners
- Condition of the fuel lines

3.4 To Start

See Graphic: wpmgr002680

3.4.1 Open fuel valve by moving lever down (**a1**).

Note: If engine is cold, move choke lever to close position (**d2**). If engine is hot, set choke to open position (**d1**).

3.4.2 Turn engine switch to “ON” (**b2**).

3.4.3 Open throttle by moving it slightly to left (**c2**).

3.4.4 Pull starter rope (**e**).

Note: If the oil level in the engine is low, the engine will not start. If this happens, add oil to engine.

3.4.5 Open choke as engine warms (**d1**).

3.4.6 Open throttle fully to operate (**c1**).

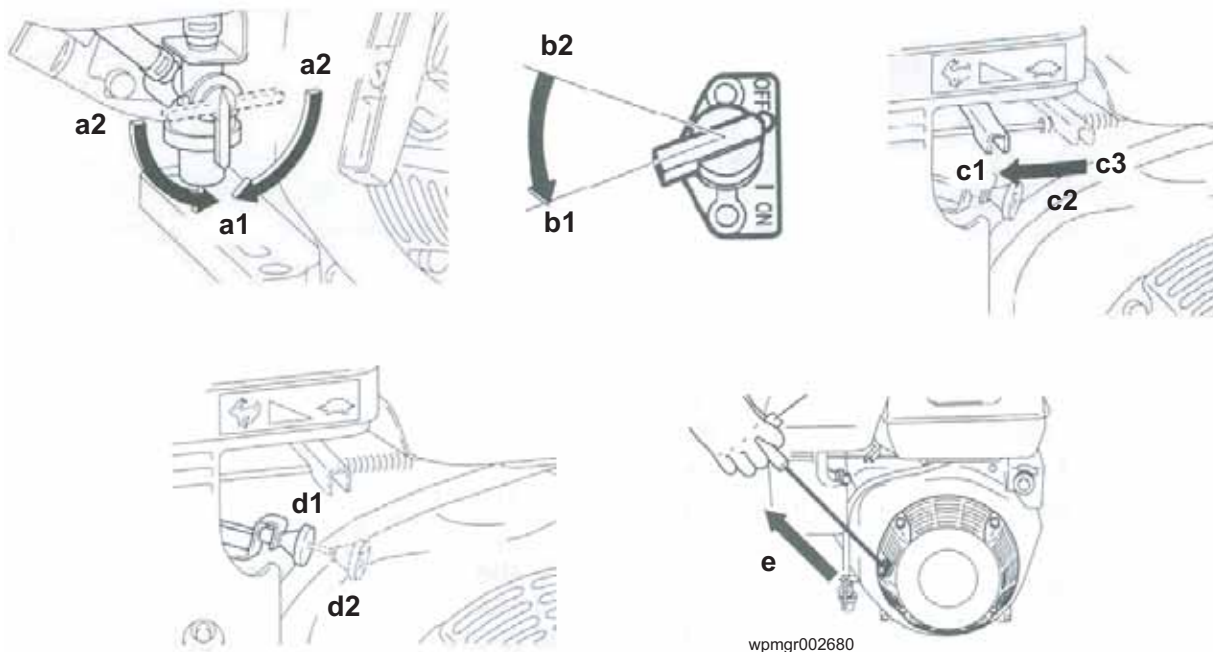

3.5 To Stop

See Graphic: wpmgr002680

3.5.1 Reduce engine RPM to idle by moving throttle completely to right (**c3**).

3.5.2 Turn engine switch to “OFF” (**b1**).

3.5.3 Close fuel valve (**a2**).

3.6 Guide Handle Adjustment

See Graphic: *wpmgr009077*

- 3.6.1 For ease of operation, the guide handle can be adjusted depending on the machine operator.
- 3.6.2 Loosen the knob (a), then push or pull the guide handle to the desired length.
- 3.6.3 Once adjusted, tighten the knob (a), to prevent the guide handle from slipping during operation.

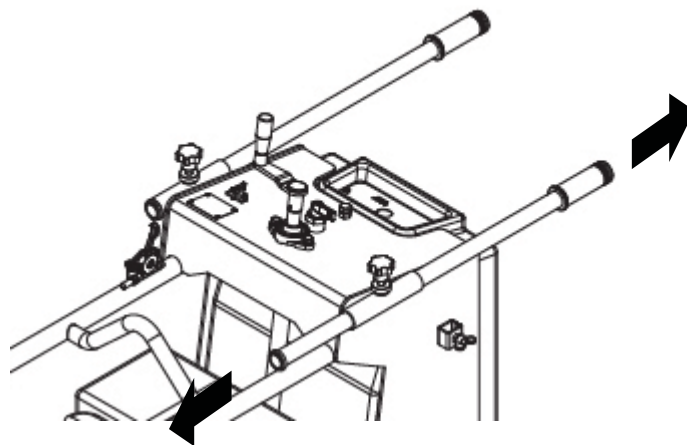

wpmgr009077

3.7 Use of Cutting Blade

3.7.1 General application instructions for use of diamond cutting blades:

- 3.7.1.1 Never use a diamond cutting blade of a diameter larger than necessary to cut down to a certain depth.
- 3.7.1.2 Pull the blade out of the cut if it has stopped turning and before restarting the engine. Check to see if the belt has been tensioned sufficient if the cutting blade should get stuck in the cut. Also check the tensioning screw and make sure that it is correctly tightened.
- 3.7.1.3 Always cut a straight line. Mark the line clearly allowing the operator to follow it easily without having to guide it from one side to the other to come back to the line (do not cut narrow curves).
- 3.7.1.4 Sufficient drive power is essential, therefore always cut with engine at full throttle.
- 3.7.1.5 Never exceed the maximum turning speed (printed on cutting blade).
- 3.7.1.6 Only use appropriate cutting blade for the material you are going to cut. Wacker has an extensive selection of diamond blades in different grades of qualities for you.

Diamond blades for asphalt are suited for:

- Asphalt
- Freshly mixed concrete (from 48 hours to 28 days old)
- Sandstone
- Sandy bricks
- Floor toppings
- Sandy limestone

Not suited for:

- Set concrete
- Hard bricks or paving setts
- Concrete with exposed aggregates by washing
- Natural stone

Diamond blades for concrete are suited for:

- Set concrete (older than 28 days with reinforcements up to maximum diameter of 6mm)

Not suited for:

- Other kind of materials



DO NOT cut into the crushed stone layer or similar material layer when working with a diamond blade. Uneven wear may occur when cutting along road edges or two different types of materials (cutting along joints). Special care is required if the material to be cut shows irregularities (eg. reinforcement bars). This could easily lead to an overloading of the cutting blade. Proceed carefully when starting a cut. Lower the blade into the material slowly.



CAUTION: Special care is required when working on slopes (lanes and surfaces). Make sure the machine is not exerting a lateral pressure on the blade.

3.7.2 Installation of Cutting Blade:

See Graphic: *wpmgr003105*

- 3.7.2.1 Make sure that the engine is switched "OFF".
- 3.7.2.2 Turn the crank (a) counter-clockwise until the machine tilts up at maximum height.
- 3.7.2.3 Disconnect the hose from the blade-guard.
- 3.7.2.4 Lift the blade-guard up from the front side.
- 3.7.2.5 Using the wrench that comes with the machine, remove the nut (c) which fastens the face-plate (d).
- 3.7.2.6 Take out the face-plate (d), and then place the blade (e) through the shaft next to the supporting disc (f), making sure that the safety pin (g) is fitted into the blade hole (h).
- 3.7.2.7 Then re-install the face-plate (d) and secure by tightening the nut (c).
- 3.7.2.8 Lower the cutting blade guard back down.
- 3.7.2.9 Reconnect the hose to the blade-guard.

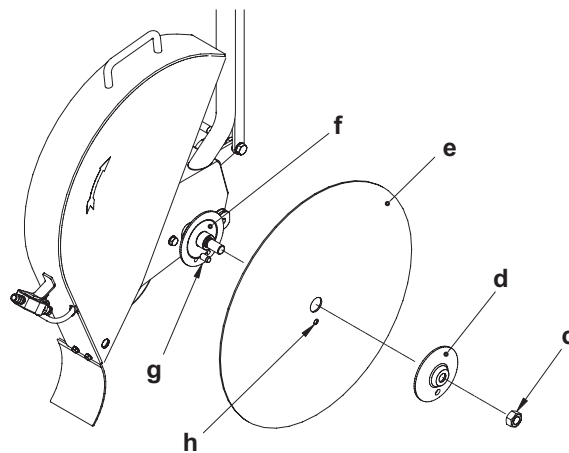

wpmgr003105

3.7.3 Removal of Cutting Blade:

See Graphic: *wpmgr003105*

- 3.7.3.1 Make sure that the engine and the water feed is switched "OFF", and the blade is cool.
- 3.7.3.2 Turn the crank **(a)** counter-clockwise until the blade no longer touches the floor.
- 3.7.3.3 Disconnect the hose from the blade-guard.
- 3.7.3.4 Lift the blade-guard up from the front side.
- 3.7.3.5 Loosen & remove the nut, and then remove the face-plate and the blade from the shaft.
- 3.7.3.6 Lower the cutting blade guard back down.
- 3.7.3.7 Reconnect the hose to the blade-guard.

NOTE: Store the face-plate, nut and the cutting blade in such a way as to avoid them getting dirty. Assemble these parts back before transport of the machine.

3.8 Guide Wheel

See Graphic: *wpmgr009078*

The Guide Wheel makes the job of cutting long straight cuts easier.

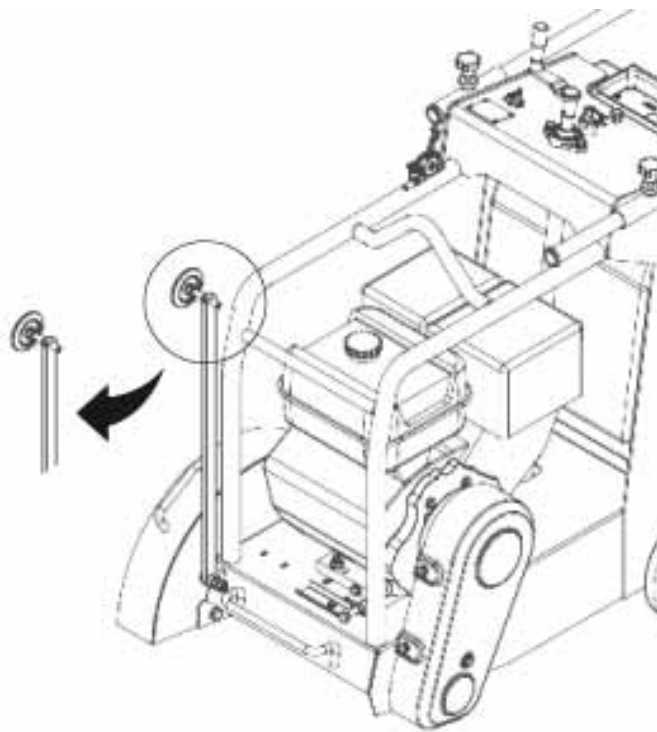

wpmgr009078

3.9 Cutting Depth Adjustment

See Graphic: wpmgr009079

The cutting depth can be precisely set with the crank (a). One turn of the crank is equal to 5 mm (0.20 in) cutting depth.

A clockwise turn deepens the cutting depth.

A counter clockwise turn reduces the cutting depth.

Note: Make sure that the engine is in full throttle before and during cutting operation.

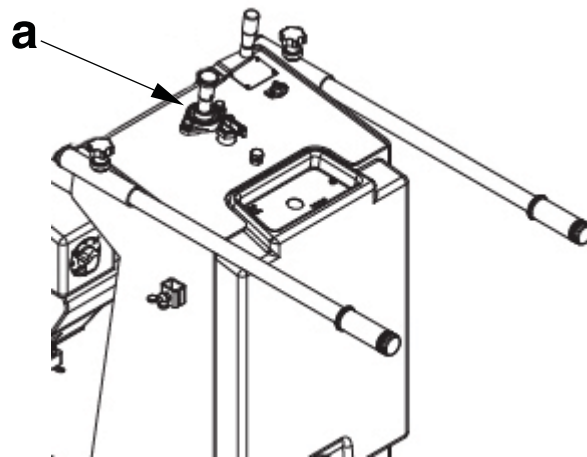

wpmgr009079

4. Maintenance

4.1 Periodic Maintenance Schedule

The chart below lists basic engine maintenance. Refer to the engine manufacturer's Operation Manual for additional information.

	Daily before starting	After first 20 hrs.	Every 2 weeks or 50 hrs.	Every month or 100 hrs.	Every year or 300 hrs.
Check fuel level.	■				
Check engine oil level.	■				
Inspect fuel lines.	■				
Inspect air filter. Replace as needed.	■				
Check external hardware.	■				
Check and adjust drive belt.		■	■		
Clean air cleaner elements.			■		
Change engine oil.		■		■	
Clean engine cooling fins.				■	
Clean sediment cup / fuel filter.				■	
Check and clean spark plug.				■	

4.2 Spark Plug

See Graphic: *wc_gr000028*

Clean or replace the spark plug as needed to ensure proper operation. Refer to your engine operator's manual.



WARNING

The muffler becomes very hot during operation and remains hot for a while after stopping the engine. Do not touch the muffler while it is hot.

Note: Refer to section "Technical Data" for the recommended spark plug type and the electrode gap setting.

- 4.2.1 Remove the spark plug and inspect it.
- 4.2.2 Replace the spark plug if the insulator is cracked or chipped.
- 4.2.3 Clean the spark plug electrodes with a wire brush.
- 4.2.4 Set the electrode gap (**a**).
- 4.2.5 Tighten the spark plug securely.

NOTICE: A loose spark plug can become very hot and may cause engine damage.

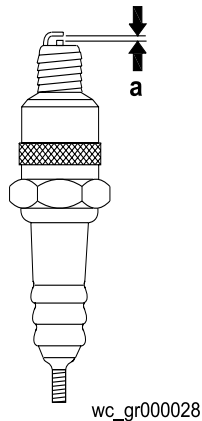

4.3 Air Cleaner

See Graphic: wpmgr009060



WARNING

NEVER use gasoline or other types of low-flash point solvents for cleaning the air cleaner. A fire or explosion could result.

NOTICE: NEVER run the engine without the air cleaner. Severe engine damage will occur.

The engine is equipped with a dual-element air cleaner. Under normal operating conditions, the elements should be cleaned once every week. Under severe, dry and dusty conditions, the elements should be maintained daily. Replace an element when it is saturated with dirt that cannot be removed.

- 4.3.1 Open the air cleaner cover **(a)**. Remove the filter assembly by pulling it straight up. Inspect both elements for holes or tears. Replace damaged elements.
- 4.3.2 Wash the foam element **(b)** in a solution of mild detergent and warm water. Rinse it thoroughly in clean water. Allow the element to dry thoroughly.
- 4.3.3 Tap the paper element **(c)** lightly to remove excess dirt or blow compressed air through the filter from the inside out. Replace the paper element if it appears heavily soiled.

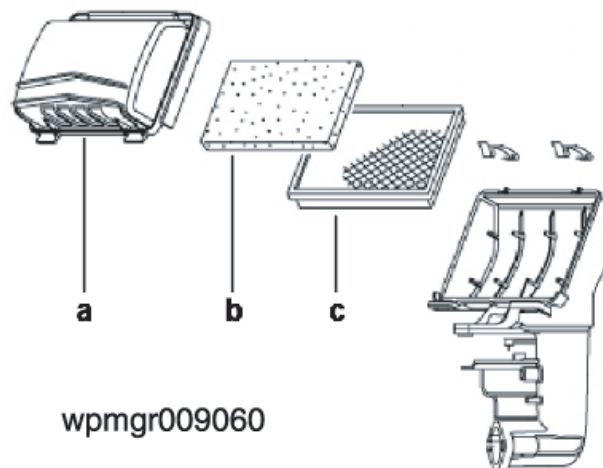

4.4 Engine Oil

See Graphic: wc_gr000087

4.4.1 Drain oil while engine is still warm.

Note: *In the interests of environmental protection, place a plastic sheet and a container under the machine to collect any liquid which drains off. Dispose of this liquid in accordance with environmental protection legislation.*

4.4.2 Remove the oil drain plug **(a)**.

4.4.3 Allow the oil to drain.

4.4.4 Install the drain plug.

4.4.5 Fill the engine crankcase through the oil filler opening **(b)**, to the upper mark on the dipstick **(c)**. Do not thread in the dipstick to check the level. See *Technical Data* for oil quantity and type.

4.4.6 When the crankcase is full, reinstall the dipstick.

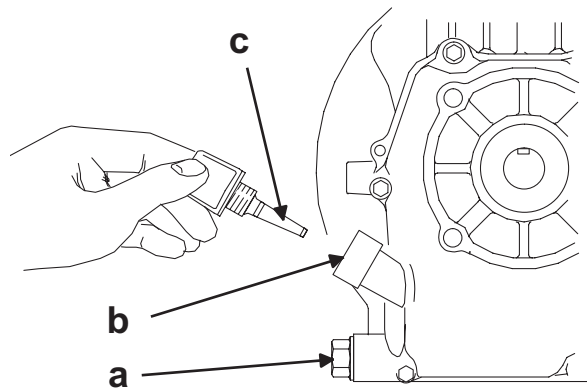

wc_gr000087

4.5 Cleaning the Fuel Strainer

- 4.5.1 To remove water and dirt, close the fuel lever and remove the fuel strainer.
- 4.5.2 Inspect the fuel strainer (**a**) for water and dirt.
- 4.5.3 After removing any dirt and water, wash the fuel cup with a nonflammable solvent.
- 4.5.4 Reinstall securely to prevent leakage.

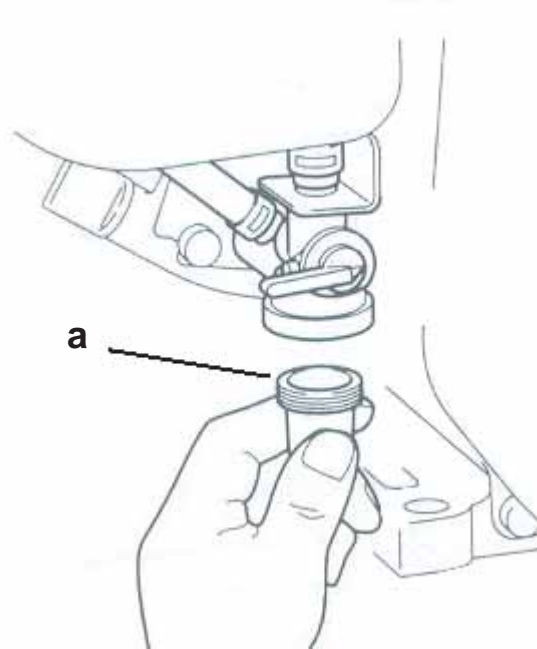

wpmgr002695

4.6 Drive Belt

See Graphic: wpmgr008205

To check belt tension or replace the belt:

- 4.6.1 Loosen the four screws **(a)** and remove the beltguard keeping the screw assemblies captured on the beltguard. Then loosen screw **(f)** which holds the beltguard into the frame.
- 4.6.2 Loosen the four nuts **(b)** which hold the engine to the frame assembly.
- 4.6.3 When replacing a belt, attach the new belt into the pulley **(e)** and into the clutch **(d)**. Tension the belt by adjusting the tensioning screw **(g)**. To check for proper belt tension, belt should deflect 10-12 mm (0.40-0.48 in) when pressed midway **(c)** between clutch **(d)** and pulley **(e)**.
- 4.6.4 When belt tension is attained, tighten the four nuts **(b)** on the engine base.
- 4.6.5 Tighten the screw **(f)** and re-install the beltguard. Fasten the four beltguard screws **(a)**.

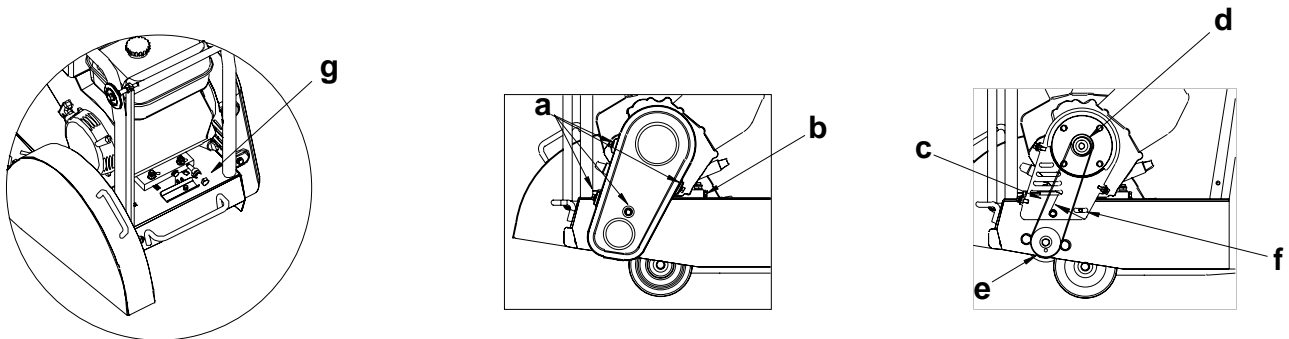

wpmgr008205

4.7 Lifting the machine

See Graphic: wpmgr009087

To lift the machine manually:

- 4.7.1 Switch the engine to "OFF" and empty the water tank.
- 4.7.2 Fold up the guide wheel and remove the cutting blade.
- 4.7.3 Turn the crank so that the machine is in its lowest cutting position.
- 4.7.4 Obtain help from a partner and plan the lift.



CAUTION

CAUTION: To avoid burns or fire hazards, let the engine cool before transporting the machine or storing it indoors. Turn "OFF" the fuel valve and keep the engine level to prevent fuel from spilling.

- 4.7.5 Grasp the machine by the lifting handles **(a)** and **(b)**, as shown.
- 4.7.6 DO NOT use the guide handle or other machine parts as lifting points.

To lift the machine mechanically:



CAUTION

CAUTION: Before attempting to lift, be sure that lifting devices can safely handle weight of machine. See Technical data for weight of machine.

- 4.7.1 Switch the engine to "OFF" and empty the water tank.
- 4.7.2 Fold up the guide wheel and remove the cutting blade.
- 4.7.3 Turn the crank so that the machine is in its lowest cutting position.
- 4.7.4 Attach hook, harness or cable to machine lifting frame **(c)** as shown, and lift as desired.
- 4.7.5 DO NOT use the guide handle or other machine parts as lifting points.

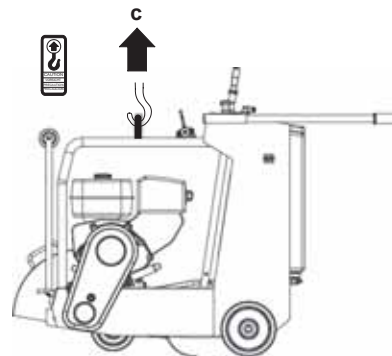
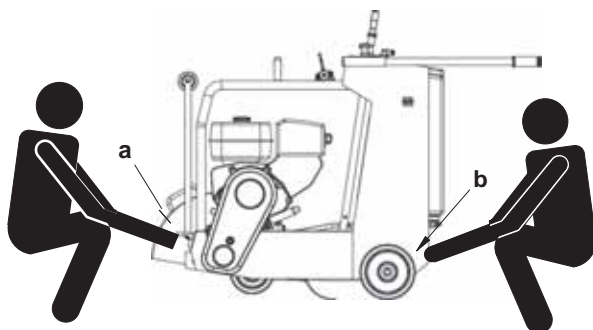

wpmgr009087

4.8 Transporting Machine

See Graphic: *wpmgr009088*



WARNING

To avoid burns or fire hazards, let engine cool before transporting machine or storing indoors.

- 4.8.1 Turn fuel valve to the off position and keep the engine level to prevent fuel from spilling.
- 4.8.2 Tie down machine on vehicle to prevent machine from sliding or tipping over. Tie machine to vehicle at points shown on graphic.

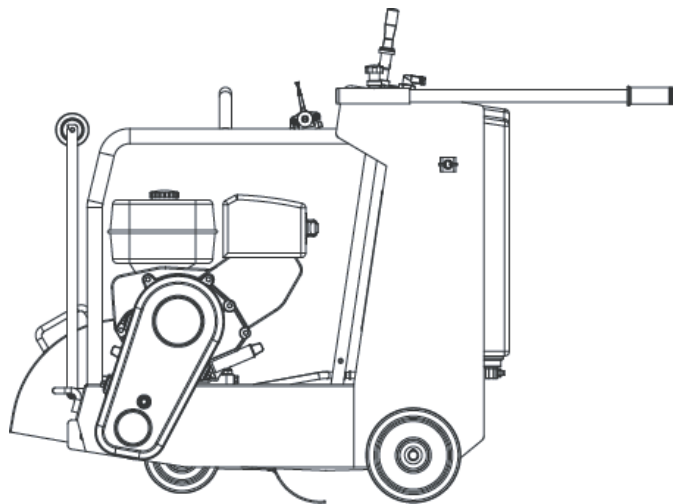

wpmgr009088

4.9 Storage

If the machine will be stored for more than 30 days:

- 4.9.1 Remove dirt from the machine.
- 4.9.2 Empty the water tank.
- 4.9.3 Clean or replace engine air filter.
- 4.9.4 Change engine oil and clean engine thoroughly with an oiled cloth.
- 4.9.5 Place multi-purpose grease on the rear wheel's valve stem.
- 4.9.6 Cover the machine and store in a clean dry area.

Wacker Neuson SE, Preußenstraße 41, D-80809 München, Tel.: +49-(0)89-3 54 02-0 Fax: +49 - (0)89-3 54 02-390
Wacker Neuson Production Americas LLC, N92W15000 Anthony Ave., Menomonee Falls, WI 53051

Tel.: (262) 255-0500 Fax: (262) 255-0550 Tel.: (800) 770-0957

Wacker Neuson Limited - Room 1701-03 & 1717-20, 17/F. Tower 1, Grand Century Place, 193 Prince Edward Road West, Mongkok, Kowloon, Hongkong.
Tel: (852) 3605 5360, Fax: (852) 2758 0032