

DIAMOND®

OPERATING/SAFETY ORIGINAL INSTRUCTIONS

DBR-32HD

REBAR STRAIGHTENER



TO REDUCE THE RISK OF INJURY, YOU MUST READ AND
UNDERSTAND THIS INSTRUCTIONS

IKK CO., LTD.

396-59, Ashitaka, Numazu-City,
Shizuoka Pref. Japan. 410-0001

Tel: +81 55 922 8811

Fax: +81 55 922 2880

E-Mail: international@diamond-ikk.com

CONTENTS

	PAGE
GENERAL SAFETY RULES -----	2
PARTS NAME -----	6
SPECIFICATION -----	6
INTERIOR ANGLE -----	7
PRE-SUE CHECKS -----	7
OPERATING INSTRUCTIONS -----	8
BENDING HOOK -----	8
WARM UP -----	8
OPERATION -----	8
PUSH -----	9
PULL -----	9
POINTS OF ATTENTION -----	10
CLEANING -----	10
OIL-LEVEL CHECK (ADD OIL) -----	11
BOLT TIGHTNESS -----	12
CARBON BRUSHES -----	12
OVERHAUL -----	12

THESE TOOLS ARE FOR INDUSTRIAL USE ONLY.

GENERAL SAFETY RULES

WARNING: REARD AND UNDERSTAND ALL INSTRUCTIONS.

Failure to follow all instructions listed below may result in electric shock, fire and/or serious injury. The term “power tool” in all of the warnings listed below refers to your mains-operated (corded) power tool or battery-operated (cordless) power tool.

WORK AREA SAFETY

- **Keep work area clean and well lit.** Cluttered or dark areas invite accidents.
- **Do not operate power tools in explosive atmospheres, such as in the presence of flammable liquids, gases or dust.** Power tools create sparks which may ignite the dust or fumes.
- **Keep children and bystanders away while operating a power tool.** Distractions can cause you to lose control.

ELECTRICAL SAFETY

- **Power tools plugs must match the outlet. Never modify the plug in any way. Do not use any adapter plugs with earthed (grounded) power tools.** Unmodified plugs and matching outlets will reduce risk of electric shock.
- **Avoid body contact with earthed or grounded surfaces such as pipes, radiators, ranges and refrigerators.** There is an increased risk of electric shock if your body is earthed or grounded.
- **Do not expose power tools to rain or wet conditions.** Water entering a power tools will increase the risk of electric shock.
- **Do not abuse the cord. Never use the cord for carrying, pulling or unplugging the power tool. Keep cord away from heat, oil sharp edges or moving parts.** Damaged or entangled cords increase the risk of electric shock.
- **When operating a power tool outdoors, use an extension cord suitable for outdoor use.** Use of a cord suitable for outdoor use reduces the risk of electric shock.
- **Do not use AC only rated tools with a DC power supply.**

PERSONAL SAFETY

- **Stay alert, watch what you are doing and use common sense when operating a power tool. Do not use a power tool while you are tired or under the influence of drugs, alcohol or medication.** A moment of inattention while operating power tools may result in serious personal injury.

- **Use safety equipment. Always wear eye protection.** Safety equipment such as dust mask, non-skid safety shoes, hard hat, or hearing protection used for appropriate conditions will reduce personal injuries.
- **Avoid accidental starting. Ensure the switch is in the off-position before plugging in.** Carrying power tools with your finger on the switch or plugging in power tools that have the switch on invites accidents.
- **Remove any adjusting key or wrench before turning the power tool on.** A wrench or a key left attached to a rotating part of the power tool may result in personal injury.
- **Do not overreach. Keep proper footing and balance at all times.** This enables better control of the power tool in unexpected situations.
- **Dress properly. Do not wear loose clothing or jewelry. Keep your hair, clothing and gloves away from moving parts.** Loose clothes, jewelry or long hair can be caught in moving parts.
- **If devices are provided for the connection of dust extraction and collection facilities, ensure these are connected and properly used.** User of these devices can reduce dust-related hazards.
- **Keep handles dry, clean and free from oil and grease.** Slippery hands cannot safely control the power tool.

POWER TOOL USE AND CARE

- **Do not force the power tool. Use the correct power tools for your application.** The correct power tool will do the job better and safer at the rate for which it was designed.
- **Do not use the power tool if the switch does not turn in on and off.** Any power tool that cannot be controlled with the switch is dangerous and must be repaired.
- **Disconnect the plug from the power source and/or the battery pack from the power tool before making any adjustments, changing accessories, or storing power tools.** Such preventive safety measures reduce the risk of starting the power tool accidentally.
- **Do not cover air vents or operate the tool on dirt.** Use a plywood base under the tool to keep armature and fan clean. If the vents are covered, the motor will overheat and may burn out.
- **Store idle power tools out of the reach of children and do not allow persons unfamiliar with the power tool or these instructions to operate the power tool.** Power tools are dangerous in the hands of untrained users.

- **Maintain power tools. Check for misalignment or binding or moving parts, breakage of parts and any other condition that may affect the power tools operation. If damaged, have the power tool repaired before use.** Many accidents are caused by poorly maintained power tools.
- **Keep cutting tools sharp and clean.** Properly maintained cutting tools with sharp cutting edges are less likely to bind and are easier to control.
- **Use the power tool, accessories and tool bits etc., in accordance with these instructions and in the manner intended for the particular type of power tool, taking into account the working conditions and the work to be performed.** Use of the power tool for operations different from those intended could result in a hazardous situation.

SERVICE

- **Have your power tool serviced by a qualified repair person using only identical replacement parts.** This will ensure that the safety of the power tool is maintained.

SPECIFIC SAFETY RULES

- **Hold power tool by insulated gripping surfaces when performing an operation where the cutting tool may contact hidden wiring or its own cord.** Contact with a “live” wire will make exposed metal parts of the tool “live” and shock the operator.
- **Use clamps or other practical way to secure and support the workpiece to a stable platform.** Holding the work by hand or against your body is unstable and may lead to loss of control.
- **Never leave the trigger locked “ON”.** Before plugging the tool in, check that the trigger lock is “OFF”. Accidental start-ups could cause injury.
- **Keep hand away from cutting area and moving parts.**
- **Do not use dull or damaged blades, cutter blocks and rollers.** Damaged part(s) can break easily or could cause injury.
- **Maintain labels and nameplates.**

GROUNDING

- **WARNING:** Improperly connecting the grounding wire can result in the risk of electric shock. Check with a qualified electrician if you are in doubt as to whether the outlet is properly grounded. Do not modify the plug provided with the tool. Never remove the grounding prong from the plug. Do not use the tool if the cord or plug is damaged. If damaged, have it repaired by a DIAMOND service facility before use. If the plug will not fit the outlet, have a proper outlet installed by a qualified electrician.

Grounded Tools (Single Insulated Tool):

- Tools with Three Prong Plugs Tools have a three wire cord and three prong grounding plug. The plug must be connected to a properly grounded outlet. If the tool should electrically malfunction or break down, grounding provides a low resistance path to carry electricity away from the user, reducing the risk of electric shock. The grounding prong in the plug is connected through the green wire inside the cord to the grounding system in the tool. The green wire in the cord must be the only wire connected to the tool's grounding system and must never be attached to an electrically "live" terminal. Your tool must be plugged into an appropriate outlet, properly installed and grounded in accordance with all codes and ordinances.

Double Insulated Tools:

- Tools with Two Plugs. Tool marked "Double Insulated" do not require grounding. They have a special double insulation system.

EXTENSION CORDS

- Grounded tools require a three wire extension cord. Double insulation tools can use either a two or three wire extension cord. As the distance from the supply outlet increases, you must use a heavier gauge extension cord. Using extension cords with inadequately sized wire causes a serious drop in voltage, resulting loss of power and possible tool damage. Refer to the table shown to determine the required minimum wire size.

Recommended Minimum Wire Gauge for Extension Cords

	100V / 115V (50/60Hz)	230V (50/60Hz)
Cable length	Cable size (AWG)	Nominal diameter
Up to 10 m (25 ft.)	16	1.0mm ²
Up to 15 m (50 ft.)	14	1.25mm ²
Up to 30 m (100 ft.)	10	1.5mm ²

PARTS NAME

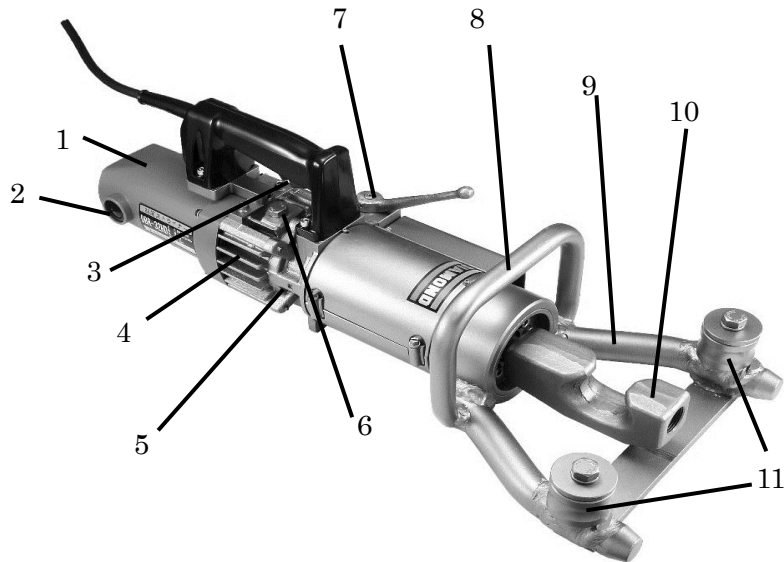

- | | |
|------------------|--------------------------------|
| 1. Motor | 7. Mode control valve lever |
| 2. Carbon brush | 8. Front handle (Housing unit) |
| 3. Switch | 9. Housing unit |
| 4. Pump case | 10. Bending Hook |
| 5. Cylinder | 11. Rollers |
| 6. Oil plug bolt | |

SPECIFICATION

MODEL	DBR-32HD
Power Supply	100V / 115V / 230V AC
Wattage	2000W
Motor	Double insulated motor
Max. rebar dia.	32mm
Bending speed	12 sec. / 90°
Bending radius	R.25mm
Max. tensile strength	620 N/mm ²
Max. Bending angle	94° / D13mm(1/2") rebar
Dimensions (LxWxH)	686 x264x 217 mm
Weight	27.8 Kg

INTERIOR ANGLE

Since the piston stroke is limited, interior straightening / bending angle will vary according to rebar diameter and operating mode. Refer to the table below:

(Accept any 620 N/mm² tensile strength rebars up to 32mm diameter.)

Rebar	Max. tensile strength 620 N/mm ²			
	Max. straightening capacity		Max. bending capacity	
	Push	Pull	Push	Pull
Diameter				
13mm (1/2")	135°	129°	94°	92°
16mm (5/8")	137°	132°	90°	90°
20mm (3/4")	140°	134°	90°	90°
25mm (1")	145°	139°	90°	90°
29mm (1 1/8")	148°	142°	90°	90°
32mm (1 1/4")	150°	145°	90°	90°

Max. straightening capacity: Interior angle of bent rebars to be straightened

***Rollers 50 (∅50.0mm) are for D25.0 to D32.0mm rebars**

***Rollers 68 (∅68.0mm) are for D13.0 to D20.0mm rebars**

WARNING: RESTRICT USE TO DESIGNATE MATERIALS

There is always a chance that the end of material may break and shoot out, especially if the material is harder than those specified. Exceeding designated material specifications greatly increase this risk and will also damage the tool. Do not attempt to use the tool for rebars harder, thicker or thinner than those specified.

PRE-SUE CHECKS

1. **WARNING:** Do not expose the tool to rain or wet conditions. Water entering a power tools will increase the risk of electric shock.
2. Wear safety goggles, safety glasses with side shields or a face shield when using these tools.
3. Check that the power source is appropriate to the tool.
CARE: If voltage is too high, the motor will burn out. If voltage is too low, insufficient power will be generated. Never use DC current.
4. Check that cord is undamaged and that plug is not loose.
CAUTION: Cut or abraded covering could result in a short and electric shock to operator.
5. Check and keep work area clean and enough work space.

6. Check condition of bending hook. Screw up bending hook surely to the depths. -
CHECK FOR CRACKS OR DAMAGE, LOOSEN BOLTS
7. *CAUTION*: Using loose bending hook may result in injury to operator as well as damage to the tool.

BENDING REBAR (Max.32mm & Tensile strength 620 N/mm²)

WARNING: Do not try to bend larger in size or rebar harder than Tensile strength 620 N/mm² or you will cause tool damage or machine failure or break rebar and shoot out.

OPERATING INSTRUCTIONS

BENDING HOOK

1. *WARNING*: Check condition of bending hook. Screw up bending hook surely to the depths. Using loose bending hook may result in injury to operator as well as damage to the tool.

ROLLERS

2. Change rollers according to rebar diameter.
 - ***Rollers 50 (ø50.0mm) are for D25.0 to D32.0mm rebars**
 - ***Rollers 68 (ø68.0mm) are for D13.0 to D20.0mm rebars**

WARM UP

3. Make sure the unit is plugged into the proper outlet 100V, 115V or 230V 50/60Hz, (Please check the voltage of your DBR-32HD.)
4. In cold weather, warm up the tool for 30-60 seconds so that the hydraulic oil reaches the proper viscosity. Pull trigger-switch to extend piston until it reaches its full stroke and then change the moving mode to retract piston to starting position. Repeat 2-3 times without rebar.

OPERATION

5. The tool is primarily intended to straighten deformed rebars. It can, of course, also be used to bend a straight rebar.

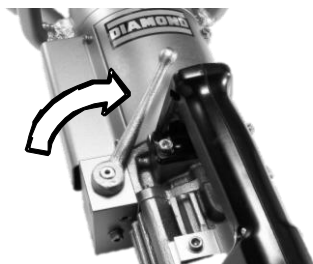

PUSH

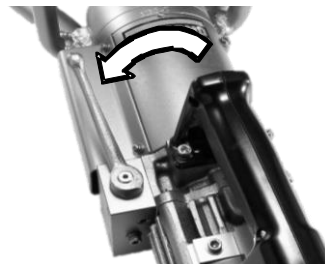

PULL

To enable the unit to be used in confined spaces, there are two operating modes: **PUSH** and **PULL**. The mode is selected by moving the mode control valve lever to the appropriate position. **PUSH** for piston advances and **PULL** for piston retracts. In either mode, simply press the switch to move the piston.

N.B. The movement of the piston is limited by a safety valve. To prevent overheating, release the trigger switch when the piston has reached its travel limit.

6. Place the rebar between the bending hook and two rollers. Making sure that it is properly in the hook and rebar should be longer than the distance of two rollers.
7. Pull trigger-switch to extend bending hook.

CAUTION: Keep hands away from moving parts while operating.

PUSH

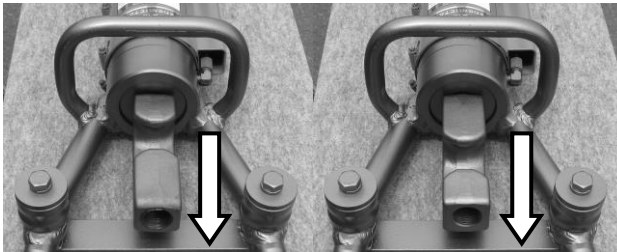

Straightening

Bending

Advance or retract the piston so that the bending hook is in a suitable starting position. Set the mode control lever to **PUSH** and fit the rebar. Pull the trigger switch until the rebar is at the desired angle.

PULL

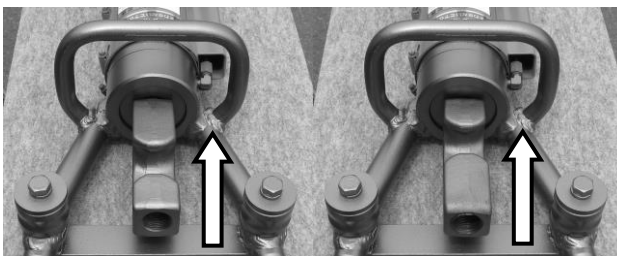

Straightening

Bending

Advance or retract the piston so that the bending hook is in a suitable position. Make sure that the mode control lever is in **PULL** position and fit the rebar. Pull the trigger switch until the desired angle is attained.

N.B. It is important that the rebar be properly fitted in the hook and against the rollers.

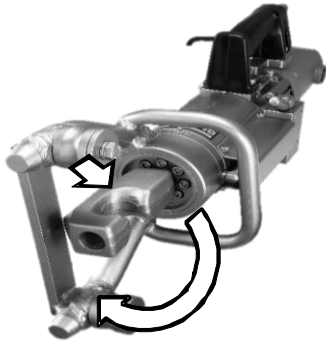

The tool can rotate the housing unit according to the working condition. Please change the direction of the bending hook (photo) to it when If turned Housing unit.

8. Switch “OFF”. Disconnect tool from outlet when not in use and before cleaning, adjusting or servicing. Do not disconnect plug from outlet by pulling the cord. Always check that the switch is OFF before plugging in

POINTS OF ATTENTION

1. Do not cover air vents.
CARE: If vents are covered, motor will overheat and may burn out.
2. If hydraulic oil exceeds 70°C (158°F) in temperature, power will drop.
Allow unit to cool before resuming operation. (Be particularly careful in summer, when the aluminum pump case heats up quicker.)
3. If a drop in power is observed and motor is an unusually hot, check carbon brush.

CLEANING

Clean your tool every day, preferably immediately after use.

WARNING: To avoid accidents always disconnect the tool from the power supply before cleaning or performing any maintenance.

1. Wipe or brush away dirt and metal filings. Keep housing and piston free of dirt and iron filings. Pay particular attention to the lower half of the piston, where dirt is more easily accumulated.
2. Once piston has been retracted, pull trigger switch long enough to partially. Unplug unit. Check piston for accumulated dirt and iron filings that may be jamming the piston.
3. Certain cleaning agents and solvents damage plastic parts.

CAUTION: Do not use an air gun: blasting with air can cause metal filings and/or dust to get into eyes and respiratory system. Wipe or brush away all dirt and metal filings.

OIL-LEVEL CHECK (ADD OIL)

As the tool is hydraulically operated, the oil-level must be checked at frequent intervals, preferably once a year. Failure to maintain the oil at the proper level results in a drop in pressure and loss of power.

CAUTION: Hydraulic oil is highly flammable. Keep away from sparks and naked flame. Do not smoke. Hydraulic oil may cause inflammation of the eyes and skin. If ingested, it could cause diarrhea and vomiting. In case of eye contact, rinse in clean water for at least 15 minutes and consult a physician. In case of skin contact, wash thoroughly with soap and water. In case of ingestion, consult a physician immediately. Do not induce vomiting.

1. Oil should be warm but not hot.
2. If piston is still moving, run the piston out to full extension (**PUSH**).
3. Unplug tool from power source.
4. Remove oil-plug and seal-washer (packing).

CAUTION: Never remove oil-plug when unit is hot or oil will spurt out.

5. Check that oil is level with bottom of plug hole (i.e. that pump case is full to the brim). If oil level is low, top up with fresh hydraulic oil with anti-foam and anti-abrasion properties (ISO viscosity grade VG32, e.g. Tellus S2 M 32 (Shell) or DTE-24 (Mobil)).
6. After topping up, extract air from system. Gently tilt tool lengthwise and return it to a level position. Top up again and tilt in the opposite direction. Repeat this process until all air has been extracted.

CARE: Tool cannot function properly if oil contains air bubbles.

7. Replace oil-plug. The operation is now complete.
8. **If oil level is too low**, Remove Air bag cover A&B.
9. Fill the tool with fresh oil. Replace the plug and lightly tighten. Connect the tool to the power source. Adjust the mode control lever and run the piston to retract (**PULL**). When the piston is completely retracted in the start position. Unplug the tool and remove the oil-plug to let overflow oil together with air (bubbles).
10. Gently tilt tool lengthwise and return it to a level position. Slowly fill the tool with fresh oil again. Replace the plug and lightly tighten. Connect the tool to the power source and advance the piston a few millimeters. Unplug the tool and remove the oil-plug. Top up oil-level and replace the plug.
11. Repeat this process till piston completely extension (**PUSH**). And squeeze the air bag with both hands, then take out unnecessary oil together with air bubble from the system. Check that oil is level with bottom of plug hole. This is full level of oil.

CARE: Tool cannot function properly if oil contains air bubbles or too much oil.

12. Replace the air bag cover, oil plug and tighten it.

13. The operation is now complete.

NOTE: Dispose of hydraulic oil in accordance with local regulations. Do not pour into the sea, a river, a lake or drains.

BOLT TIGHTNESS

Once a week, or after every 30 times use, check the tightness of all bolts. Especially those securing housing to the cylinder and bending hook. **Screw up bending hook surely to the depths.**

WARNING: Using loose bending hook may result in injury to operator as well as damage to the tool.

CARBON BRUSHES

Inspect the two carbon brushes at least once every two months. (Nominal brush life is 200 hours).

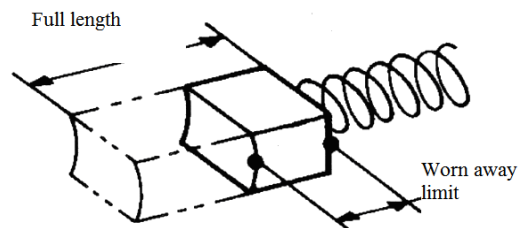

CARE: Worn brushes will result in power loss; cause the motor to run hot and irreparably damage the armature.

1. Disconnect tool from electrical outlet.

2. Remove Tail cover. Unscrew both brush caps and pull out carbon brushes.

3. Replace brushes if less than 6mm in length.

(We recommend the automatic stop carbon brush for replace.)

Standard carbon brush

Parts #.7HTK999044B

OVERHAUL

Return the unit to an authorized distributor for overhaul at least once every two years, sooner if subject to heavy use. Ignorance of proper operating procedures can lead to accidents. If you have any other questions about any procedures, please contact the nearest authorized distributor. *Specifications are subject to change without prior notice.