

Type 'FE' FORK SLIPPER

INSTALLATION and INFORMATION SHEET

1) PRODUCT DESCRIPTION

East West Engineering Fork Slippers are designed and manufactured in accordance with Australian Standard AS 2359.15, Powered Industrial Trucks – Fork Arm Extensions and Telescopic Fork Arms.

- a) Each Slipper is fitted with a compliance plate, details as shown below.
- b) The Fork Slippers are designed and supplied with locking pins that prevent unintentional disengagement from the Forks.
- c) Fork Slippers should be no longer than 167% of the supporting fork's length.
- d) If the Fork Slippers are longer than 167% of the supporting fork's length, use shall be restricted to their specified application.

Use of the forklift attachment should be in conformance with relevant statutory authorities. Use of Fork Slipper is restricted to the purpose for which it is designed. EAST WEST ENGINEERING is not liable if this restriction is breached.

2) INSTALLATION PROCEDURE

To install the Slipper onto a Fork Arm, engage the Slipper over the Fork Arm as shown in *Fig. 2.1* below. With the rear of the Slipper firmly against the Fork Arm shank (vertical face), slide the Locking Pin supplied through the holes in the Slipper bracket behind the Fork Arm and rotate the safety clip vertical to secure in position.

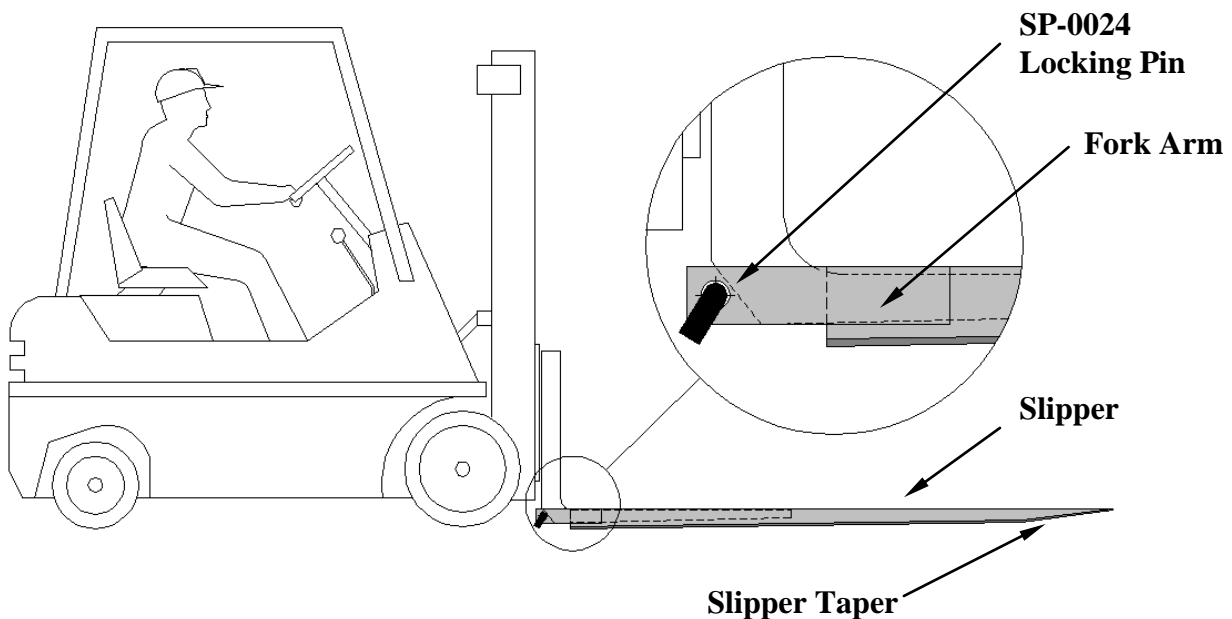

Fig. 2.1

3) **COMPLIANCE PLATE INFORMATION**

“Type”	“A”	“B”	“C”	“D”	“E”
FE1-16	1250	500	100	45	960
FE1-18	1250	500	100	45	1068
FE1-21	1250	500	100	45	1260
FE1-24	1250	500	100	45	1440
FE2-16	2000	500	130	50	960
FE2-18	2000	500	130	50	1068
FE2-21	2000	500	130	50	1260
FE2-24	2000	500	130	50	1440
FE3-16	2500	500	155	55	960
FE3-18	2500	500	155	55	1068
FE3-21	2500	500	155	55	1260
FE3-24	2500	500	155	55	1440
FE3-30	2500	500	155	55	1800
FE4-18	4000	600	160	65	1068
FE4-21	4000	600	160	65	1260
FE4-24	4000	600	160	65	1440
FE4-30	4000	600	160	65	1800

Table 3.1 (Refer Fig.3.2 below)



Fig.3.2

(Compliance Plate: positioned on the side of each Slipper)

- Notes:**
- 1) Fork Size shown on the Compliance Plate (“C”, “D” & “E”) are the recommended tine dimensions required for the specified Slipper.
 - 2) “YM” is the Year of Manufacture (e.g. 2015).

4) **CERTIFICATION INFORMATION**

We certify that the Fork Slippers are designed and fabricated strictly in accordance with Australian Standard:

AS 2359.15 – 2005

Powered Industrial Trucks – Fork Arm Extensions and Telescopic Fork Arms

5) **TERMS of TRADE, CONDITIONS of SALE and WARRANTY STATEMENT**

1. East West Engineering (EWE) products are to be used only as indicated. Misuse or misapplication may cause failure resulting in possible property damage or bodily injury.
2. It is the obligation of the user to ensure EWE products are used in accordance with appropriate Codes and System requirements.
3. All liability for EWE products performance is disclaimed and the warranty will be voided if any of the following conditions exist:
 - 3.1) the product is used beyond the published or stated rate load limit. Note: all ratings are for static conditions and do not account for dynamic loading such as wind, water or seismic loads.
 - 3.2) the product is not properly installed per published or stated instructions
 - 3.3) the loading to the product is not vertical
 - 3.4) the product is deformed or stressed in any way during fitting or installation.
 - 3.5) the product is used in a corrosive environment.
4. All safety regulations required by the user must be observed.
5. EWE products at the time of dispatch are warranted to be free of defects in material or workmanship. **NO OTHER WARRANTY EXPRESSED OR IMPLIED SHALL EXIST IN CONNECTION WITH THE SALE OR USE OF EWE PRODUCTS.** Claims for errors, shortages, defects or non-conformities ascertainable upon inspection must be made in writing within 15 days after buyer's receipt of products. All other claims must be made to EWE within 12 months of the date of shipment for products hydraulically operated and within 12 months for products without hydraulics. Products claimed nonconforming or defective must upon EWE's request promptly be returned for inspection. Claims not made as provided above and within the applicable time period will be barred. EWE shall in no event be responsible if the products have not been used in accordance with the specifications and/or recommended procedures. EWE will, at its option either repair or replace nonconforming or defective products for which it is responsible or return to buyer their purchase price. The foregoing states buyer's exclusive remedy for any breach of EWE warranty and for any claim, whether sounding in contracts, tort or negligence for loss or injury caused by the sale or use of any product. Without limiting the generality of the foregoing EWE shall in no way be responsible for any loss of business or profits, downtime or delay, labour, repair or material cost or any similar or dissimilar consequential loss or damage incurred by the Buyer.
6. Examine goods immediately upon receipt and advise any damage or shortage to carriers and ourselves within 15 days, otherwise no claim whatever will be considered. Provided advice is given within the prescribed time, we will make good any shortage and will repair or replace free of charge goods damaged in transit where we are responsible for delivery of the goods.
7. If goods are not received within 14 days from receipt of invoice please advise us in writing.
8. If any error is discovered in this invoicing please notify supplying branch at once for correction.
9. Property and Payment – By acceptance of delivery and retention of the goods it is acknowledged that the property of the goods remains with EWE and that legal title thereto will not pass until payment is made but that nevertheless the goods are at your risk after delivery. In the event that payment is not made within 30 days of delivery, or other agreed terms, full licence and authority is given to EWE to enter any premises where the goods are stored and to recover possession of them. In the event of the sale of the goods prior to payment, the proceeds of sale belong to EWE.
10. Terms of Payment – Unless credit has been arranged strictly net cash; if credit has been arranged payment must be made by the 25th day of the month, following the month appearing in the date on the front of this invoice.
11. **East West Engineering reserves the right to alter specifications, designs and price without notification**